

University of Southern Queensland
Faculty of Engineering and Surveying

Grinding Mill Conceptual Design Developments

A dissertation submitted by

Ian G. Commons-Fidge

In fulfilment of the requirements of

Courses ENG4111 and ENG4112 Research Project

Towards the degree of

Bachelor of Engineering (Mechanical)

Submitted: 28 October 2010

ABSTRACT

The aim of this project was to identify problematic areas currently existing within the grinding industry and develop conceptual solution to reduce and where possible eliminate them. To achieve this, a broad investigation into the milling industry was undertaken to identify:

- Current milling equipment and processes
- Use and application of this equipment
- Industry acknowledged deficiencies and limitation
- General research and development trends relating to this limitations
- Commercial expectations of users
- Technology trends within the milling industry

Using this industry knowledge, significant problem area were identified and brainstormed for possible equipment or procedural modification which could reduce the effects of these limitations.

The conceptual designs spawned were scrutinised using a range of evaluation tools to identify ideas exhibiting genuine development potential. The concepts were tested against a range of industry considerations from:

- Operational
- Commercial
- Safety
- Environmental

Several concepts were then further development using theoretical concept designing coupled with three dimensional solid modelling. The systems produced could offer the grinding industry solutions to long standing industry limitations as well as more efficient production with improved safety profile. Although still at a conceptual development stage, the ideas set out detail manufacturing part designs and examples of industry application. Organisations who wish to further develop these concepts are encouraged to do so.

University of Southern Queensland
Faculty of Engineering and Surveying

**ENG4111 Research Project Part 1 &
ENG4112 Research Project Part 2**

Limitations of Use

The Council of the University of Southern Queensland, its Faculty of Engineering and Surveying, and the staff of the University of Southern Queensland, do not accept any responsibility for the truth, accuracy or completeness of material contained within or associated with this dissertation.

Persons using all or any part of this material do so at their own risk, and not at the risk of the Council of the University of Southern Queensland, its Faculty of Engineering and Surveying or the staff of the University of Southern Queensland.

This dissertation reports an educational exercise and has no purpose or validity beyond this exercise. The sole purpose of the course "Project and Dissertation" is to contribute to the overall education within the student's chosen degree programme. This document, the associated hardware, software, drawings, and other material set out in the associated appendices should not be used for any other purpose: if they are so used, it is entirely at the risk of the user.



Professor Frank Bullen
Dean
Faculty of Engineering and Surveying

Certification

I certify that the ideas, designs and experimental work, results, analyses and conclusions set out in this dissertation are entirely my own effort, except where otherwise indicated and acknowledged.

I further certify that the work is original and has not been previously submitted for assessment in any other course or institution, except where specifically stated.

Ian G Commons-Fidge

Student Number: 00111226579



Signature

28/10/2010

Date

Acknowledgements

In the preparation of this paper I would like to thank the following people and organisations that made a genuine contribution to the development of this research and the conceptual solutions that ensued.

Mining organisations in the Northern Territory that responded to email communications and telephone enquiries regarding the use and limitations of their grinding equipment. In particular I would like to thank Edward Carrigan and Dan Smith of Xstrata Zinc's, McArthur River Mine. Both men made themselves available for discussion which provided valuable insight to a user perspective of grinding equipment.

My USQ supervisor, Steven Goh. He was extremely flexible with his meeting and correspondence time during the first Semester of the course, when I was overseas and frequently changing time zones. His enthusiasm for the subject and suggestions during my research and conceptual development were invaluable and much appreciated.

Finally my partners and staff at N.T. Acrylic & Plastics in Darwin. They have been willing to support me with irregular work shifts to complete my report and submit it on time.

Thankyou to those listed above and anyone else not mentioned who contributed to the completion of this report.

TABLE OF CONTENTS

Abstract	ii
Limitations of Use	iii
Certification	iv
Acknowledgements	v
Table of Contents	vi
List of Figures	xi
List of Tables	xii
Abbreviations	xii
Chapter 1 – Introduction										1
1.1	Introduction	1
1.2	Project aims	1
1.3	Project objectives	2
1.4	Scope	2
Chapter 2 – Methodology										4
2.1	Introduction	4
2.2	Literature review			4
2.3	Concept formation	4
2.4	Concept review	4
2.5	Concept development			5
Chapter 3 – Literature Review										6
3.1	Introduction	6
3.2	Comminution	6
3.3	Overview of the comminution process			7
3.4	Blasting	7
3.5	Crushing	8
3.6	Grinding	8
3.7	Mill design and specification	9
3.8	Operations and production considerations	9
	3.8.1	Ore Hardness and Composition		10
	3.8.2	Speed	10
		3.8.2.1	Grinding Motion	10

3.8.2.2	Discharge	12
3.8.3	Through-put Tonnage	13
3.8.4	Operating Volume	14
3.8.5	Wet or Dry Grinding	15
3.9	Equipment selection	15
3.10	Autogenous mill	15
3.11	Semi-Autogenous mill	16
3.12	Ball and rod mill	17
3.13	Grinding media	17
3.14	The mill	18
3.14.1	Feed head	18
3.14.2	Feed head liner	19
3.14.3	Shell	19
3.14.4	Shell liners	19
3.14.4.1	Liner/lifter design	20
3.14.4.2	Construction materials	20
3.14.4.3	Grinding participation	20
3.14.5	Discharge head	22
3.14.6	Grate	23
3.14.7	Pulp lifter	25
3.15	Commercial considerations	26
3.15.1	Capital and setup costs	27
3.15.2	Production	27
3.15.3	System configuration	27
3.15.4	Consumables	28
3.15.5	Maintenance	28
3.15.5.1	Maintenance planning	28
3.15.5.2	Programmed maintenance	29
3.16	Environmental considerations	29
3.17	Occupational Health and Safety considerations	30
Chapter 4 – Design concept solutions									31
4.1	Introduction	31
4.2	Design concept # 1	31
4.3	Design concept # 2	33
4.4	Design concept # 3	34
4.5	Design concept # 4	36
Chapter 5 – Evaluation									38
5.1	Introduction	38
5.2	Evaluation tool	39

5.3	Criterion description and weighting	40
5.3.1	Introduction	40
5.3.2	Production	40
5.3.2.1	Bi-Directional Capability	40
5.3.2.2	Increase pulp transfer through grate openings	40
5.3.2.3	Reduce pulp Backflow	40
5.3.2.4	Improves Pulp Lifter discharge efficiency	40
5.3.2.5	Suitable with variable mill speeds	40
5.3.2.6	Suitable with variable charge volumes	41
5.3.2.7	Suitable with variable ball sizes	41
5.3.2.8	Compatible with overflow discharge systems	41
5.3.2.9	Compatible with Grate & Pulp lifters systems	41
5.3.2.10	Compatible with trunnion supported mills	41
5.3.2.11	Compatible with shell support mills	41
5.3.2.12	Compatible with wet grinding	41
5.3.2.13	Compatible with audio sensory equipment	42
5.3.2.14	Reduced abrasive wear	42
5.3.2.15	Reduced impact damage	42
5.3.2.16	Reducing charge slippage	42
5.3.2.17	Improved charge control	42
5.3.3	Commercial	42
5.3.3.1	Reduce shut down duration	42
5.3.3.2	Reduce requirement for specialist shut-down contractors/equipment	43
5.3.3.3	Increase production tonnage per unit operating cost	43
5.3.3.4	Increase production tonnage per unit maintenance cost	43
5.3.3.5	Adaptability to existing equipment	43
5.3.3.6	Decrease capital cost for new equipment	44
5.3.4	Occupational Health and Safety	44
5.3.4.1	Decrease Loss Time Injury (LTI) risk for Mill	44
5.3.4.2	Decrease Loss Time Injury (LTI) risk for Mill	44
5.3.4.3	Reducing sound emissions	44
5.3.5	Environmental	44
5.3.5.1	Reduce consumption of operational consumables per tonne output	44
5.3.5.2	Improve energy efficiency of the grinding system	45
5.4	Critical evaluation	45
5.4.1	Result summary	45
5.4.1.1	Operation	45
5.4.1.2	Commercial	45
5.4.1.3	Safety	45
5.4.1.4	Environmental	46
5.4.1.5	Overall Performance	46

5.4.2	Concept review	46
5.4.2.1	Concept #1	46
5.4.2.2	Concept #2	46
5.4.2.3	Concept #3	46
5.4.2.4	Concept #4	46
5.4.3	Concept selection	46
Chapter 6 – Removable modular shell assembly (RMSA)									47
6.1	Introduction	47
6.2	Relining overview	47
6.3	Removable modular shell assembly	51
6.4	RMSA methodology	51
6.4.1	After the shutdown	51
6.4.2	The next shutdown	53
6.5	Integration limitations	55
6.5.1	Power Transmission and Shell Support	55
6.5.2	Head Liners, Grates and Pulp Lifters	55
6.5.3	Shell Handling and Alignment	55
Chapter 7 – Jet Propulsion Assisted Pulp Lifter (JPAPL)									56
7.1	Introduction	56
7.2	Discharge review	56
7.3	Development of the JPAPL concept	57
7.3.1	Introduction	57
7.3.2	Concept hurdles	57
7.3.3	Fluid injection	58
7.3.4	Pulp leakage and water delivery	58
7.4	JPAPL System #1	59
7.4.1	System #1 Evaluation	60
7.5	JPAPL System #2	61
7.5.1	SYSTEM #2 Evaluation	62
7.6	JPAPL System #3	63
7.6.1	System #3 Evaluation	66
Chapter 8 – Recommendations and Conclusions									68
8.1	Introduction	68
8.2	Solution	68
8.2.1	Dual shell	69

8.2.2	Peripheral spray hood and collection sump	69
8.2.3	JPAPL bi-directional array	70
8.3	Solution review	7272
8.4	Further research	72
8.4.1	Design integration	72
8.4.2	Structural analysis	73
8.4.2.1	Shell analysis	73
8.4.2.2	Water distribution	73
8.4.3	Commercial viability	73
8.5	Conclusion	73

List of References	74
--------------------	-----	-----	-----	-----	-----	-----	-----	-----	----

Bibliography	74
--------------	-----	-----	-----	-----	-----	-----	-----	-----	----

APPENDICES

A.	Project specification	A1
B.	Concept diagrams								
	Concept #1	B1
	Concept #2	B2
	Concept #3	B3
	Concept #4	B4
C.	Evaluation tool results	
	Concept #1 result	C1
	Concept #2 result	C2
	Concept #3 result	C3
	Concept #4 result	C4

LIST OF FIGURES

Figure 3.1: Comminution flow chart	7
Figure 3.2: Charge motion	11
Figure 3.3: Charge break point	11
Figure 3.4: Grate and discharge head liner	12
Figure 3.5: Pulp discharge simulation (CW rotation)	12
Figure 3.6: Pulp slurry pooling	13
Figure 3.7: Liner and lifter configurations	22
Figure 3.8: Mill discharge	23
Figure 3.9: Component identification for grate discharge	23
Figure 3.10: Pulp filling and backflow motion	25
Figure 3.11: Pulp motion during discharge	25
Figure 3.12: Curved radial pulp lifter	26
Figure 4.1: Removable Modular Shell Assembly	31
Figure 4.2: Hinged Liner Belt	33
Figure 4.3: Adjustable Deflector Plate	34
Figure 4.4: Jet Propulsion Assisted Pulp Lifter	36
Figure 6.1: RME liner handling machine and operator	48
Figure 6.2: RMSA mill component identification	49
Figure 6.3: Emptying contents	51
Figure 6.4: Liner removal from modular shell plate	52
Figure 6.5: Shell relining simulation	53
Figure 6.6: Shutdown simulation	54
Figure 6.7: Tapered flange connections	54
Figure 7.1: JPAPL System #1	60
Figure 7.2: JPAPL System #2	62
Figure 7.3: JPAPL System #3_Water injection	64
Figure 7.4: JPAPL System #3_Injection sequencing	64
Figure 7.5: Water dispenser	65
Figure 7.6: Water dispenser open/closed simulation	66
Figure 8.1: Optimal solution design...	68
Figure 8.2: Shell removal...	69
Figure 8.3: Discharge system...	70
Figure 8.4: Water distribution system...	71

LIST OF TABLES

Table 5.1: Concept evaluation tool	39
Table 5.2: Evaluation tool results summary	45

ABBREVIATIONS

ADP	...	Adjustable Deflector Plate
AG	...	Autogenous Grinding
DE	...	Discharge End
FE	...	Feed End
FEA	...	Finite Element Analysis
HBL	...	Hinged Liner Belt
JPAPL	...	Jet Propulsion Assisted Pulp Lifter
RMSA	...	Removable Modular Shell Assembly
ROM	...	Rum Of Mine
SAG	...	Semi-Autogenous Grinding

Chapter 1

Introduction

1.1 Introduction

As human population continues to grow, so too does our demand for the planet's natural resources. Be it in the form of renewable (wind and solar), semi-renewable (food, water and clean air) or finite resources (fossil fuels, metals and minerals), the human appetite to consume and develop is showing little sign of slowing.

New and developing economies like China and India are accelerating this already high global demand for commodities and resources. Part of this demand is for manufacturing and international export opportunities, however much is driven by domestic growth as third and second world populations seek to raise their standards of living by improving infrastructure and consuming broader ranges of goods and services. Many of these developing countries have some of the largest population densities on the planet, so the trend towards increased resource consumption is set to continue well into the foreseeable future.

One particular area of demand is for metals and minerals. This is evident from the 'International Resource Boom' that has been underway for the past 10 years. Miners internationally are frantically exploring for new or expanded resource deposits, with the intension of extracting and selling to market these valuable commodities. Metals like gold, copper, iron ore nickel, lead and zinc are at record demand and price levels, so the opportunities and interest in the mining industry is intense.

To meet this increasing demand miners are continually looking for more efficient methods to find and extract these resources. All areas of the recovery chain are under close scrutiny to identify competitive advantages that will allow miners to bring their product to the market with greater profitability.

1.2 Project aims

The purpose of this paper is to explore one particular area in the recovery chain, comminution. The method of comminution involves continued reduction in ore size for use in further mineral extraction processes. Mining today relies heavily on comminution equipment to dislodge, crush and grind ore and is the single largest expense in the recovery of any resource. Mr. Kenneth N. Han (2003) co-author of Principles Of Mineral Processing claims "energy intensive comminution operations use on the order of 50% of a mineral processing plant's operating costs and often carry an even larger percentage of the capital cost price tag for the plant" further to this Han (2003) highlights the need for continued develop of the comminution industry with the statistic that about 1% of the total power produced in the United States is consumed by the comminution process and possibly as much as 2% of world's energy annually.

The particular focus of this paper is the final stage of the comminution process **grinding**. It is well established that the grinding circuit adds the largest operating cost to any comminution process and achieves the least size reduction efficiency per unit energy consumed. Although

there are numerous devices available for grinding the vast majority of comminution circuits employ some combination tumbling mills to achieve the desired final product particle size. For this reason research within this paper has been focused specifically on horizontal rotating-mill equipment.

By researching the grinding industry I hoped to identify key operational and commercial factors which impact on the efficient use of milling equipment and their ability to retrieve target minerals from mined ore. Using this research database and by applying a fresh engineering viewpoint to industry problems, I hoped to improve extraction efficiency and where possible reduce operating costs.

1.3 Project objectives

The goal of this paper is to develop new and innovative conceptual ideas to improve the efficiency and sustainability of the comminution industry. This would be achieved by researching and understanding;

- The demands on the industry
- The environmental and sustainability implications on the industry
- How the industry operates
- What equipment is used and how it is used
- What industry acknowledged limitations and deficiencies exist
- Where is the future direction of the industry

Using this knowledge, I intended to identify new and innovative solutions to combat and hopefully overcome some of these identified weaknesses. These solutions would aim to (where possible) eliminate identified problems or substantially reduce their impact on the industry. Ultimately, I hoped the ideas spawned from this research would aid in improving the commercial viability of milling and the efficiency of mineral recovery by comminution.

1.4 Scope

The scope of this dissertation is to present new component and operational ideas to the comminution industry. Beneficiaries of this report will span widely from equipment manufacturers, to maintenance providers and direct mill users. This chapter identifies the broader objectives of this research and the expected outcomes achieved by the conclusion.

Chapter 2 is included to explain the research, discovery, design and development methodology used for this report. It identifies how the project objectives were achieved and what methods were applied.

Chapter 3 presents a summary 'Literature Review', of the research discovery. The literature initially identifies then broader process of comminution and how it is currently used by the mining industry. Then a detailed examination of grinding equipment is undertaken, identifying significant components, their purpose and operational relationship with other mill parts. Finally, a look at broader commercial, safety and environmental considerations is undertaken. During

presentation of the literature review, a conscious effort was made to identify and document limitations and deficiencies within the grinding industry as conceptual solution objectives.

Chapter 4 introduces four conceptual design solutions. Each solution combats one or several of the limitations identified during the literature review. The concepts are presented with an illustrative solution sketch, a concept description and a generalised solution overview. Also, a list of possible advantages and disadvantages of the concept is presented.

Chapter 5 introduces the method of critical evaluation used to examine the conceptual designs and determine their realistic commercial value. This is achieved by scoring each concept against a range of operational, commercial, safety and environmental tests which is collated in a table format. Test explanations are included in this chapter to clarify the significance of the test. In addition, each test item is allocated a score weighting according to the significance of the assessment criterion. Finally in Chapter 5, a summary of the test results is presented and commercially viable concepts identified.

The Removable Modular Shell Assembly (RMSA) is further developed during Chapter 6. The system methodology is explained in detail and a simulated life cycle is presented. During this presentation the concept is critiqued for solution advantages and limitations.

The Jet Propulsion Assisted Pulp Lifter (JPAPL) system is further developed in Chapter 7. The concept idea is initially developed broadly and then three specific design solutions identified. Each solution is critiqued for advantages and limitations.

Chapter 8 presents a combined recommended concept design to the reader. The design draws on ideas and processes identified during the previous chapters and makes recommendations as to how the optimal concept could be implemented and utilised by industry. Finally a summary of the research is presented to conclude the dissertation.

Chapter 2

Methodology

2.1 Introduction

This chapter is included to detail the approach undertaken during this dissertation to achieve the project objectives set out in the 'Project Specification' as seen in Appendix A. In summary two objectives are set out. First, to *identify limitations and deficiencies* currently acknowledged within the grinding industry and secondly to *develop new conceptual solutions* to overcome or reduce these problems and increase the operational efficiency of the industry.

2.2 Literature Review

The platform from which the first part of the project objectives would be achieved was through a thorough Literature Review. This was allocated the single largest block of project time and ran for almost two months. During this time a broad investigation of the industry, the equipment and the processes used was undertaken. Information sources included research journals, resource and text books, magazine articles, as well as company and industry networking web sites.

During this research discovery phase, particular attention was focused on system or equipment problems. Any mention of deficiency warranted further research to verify if the issue was still current, what research had been previously undertaken in the field, and if any new technology was available to reduce or limit the problem. A deficiency that was well acknowledged but had little improvement in recent time was identified as high priority focus point.

2.3 Concept formation

During the collation and identification of this industry database and deficiency list, problem focus points were continuously brainstormed to produce concept solution ideas. While the literature review was continuing, any potential ideas were recorded and referenced to when new information surfaced applicable to the problem. Ideas that remained valid at the completion of the literature review were then developed to a conceptual design level.

The concepts were not intended to be resolved to a commercially implementable level, rather, a generalised presentation of how the idea should work and what its initial advantages and disadvantages were. These primary concepts could then be analytically measured against one another to determine which ideas possessed the greatest potential benefit.

2.4 Critical review

The critical review was achieved by developing an evaluation template. Industry objectives and requirements identified during the literature review were detailed as test points in the evaluation template. Test items were grouped under four headings; operations, commercial, safety and environmental. In addition (and to reflect the significance of the specific test), each item was allocated a score weighting.

Each conceptual idea was subjected to the critical review evaluation. Section scores (e.g. operational, commercial ...) and an overall total score was determined and all results recorded and displayed in a results table. These results could then be easily compared to determine which concepts should be developed.

2.5 Concept development

Once concepts were identified for further development, the ideas were then subjected to closer investigation relating to part design and system application. The reader will notice that this dissertation differs from more traditional engineering dissertations in that no experimental work was possible to achieve the project objectives. Rather, the experimental work was substituted for theoretical design and three dimensional modelling simulations. Combined, the concepts could be presented to the reader with a visual representation of the proposed system and examples of how the concepts would be practically applied in industry.

Due to the conceptual nature of the research work though, no definitive design results are offered to the reader at the conclusion of this report. Instead, the reader can expect to be presented a myriad of potential solutions that will require further research to verify their commercial viability.

Chapter 3

Literature Review

3.1 Introduction

“Comminution is a process whereby particulate materials are reduced by blasting, crushing and grinding to the product sizes required for downstream processing or end use” HAN (2003). These end uses differ widely, for the production of energy like coal or uranium, to the extraction of construction metals including iron ore, copper and zinc. Mining and the extraction of resources continues to expand as human population grows and along with it consumer demand.

To meet this growing resource demand, the mining industry has itself needed to grow, evolve and increase its efficiency and production outputs. Easily retrievable alluvial deposits have long since been consumed and more difficult deposits are now being exploited. Mining is today taking place where previously it was impossible to access or recover. Today mines are deeper, more remote, have lower grades and more challenging ore compositions. The mining industry continues to meet these challenges with innovation and technological development. Improved exploration and geological surveying, developments in metallurgical processing and advancements in comminution processing circuits has made recovery of these deposits economically viable.

The literature review detailed in this section of the report focuses on the one area of the mineral recovery process: Comminution, and in particular ‘Horizontal Rotating Grinding Mills.’ The following subsections detail the process of comminution, the equipment used to achieve size reduction and the commercial implications/considerations relevant to comminution users. This literature review forms the base from which further analytical analysis will be performed on conceptual ideas to improve efficiency within the industry.

3.2 Comminution

The flow chart presented in figure 3.1 is included to assist the reader follow the development and presentation of research literature. During the literature review the reader is encouraged to refer to this chart to better understand how the topic being presented relates to the comminution industry and interconnected equipment or processes. It also illustrates a clear progression from the broader comminution activities (blasting, crushing and grinding) through to grinding specific equipment and industry considerations associated with using horizontal grinding machinery.

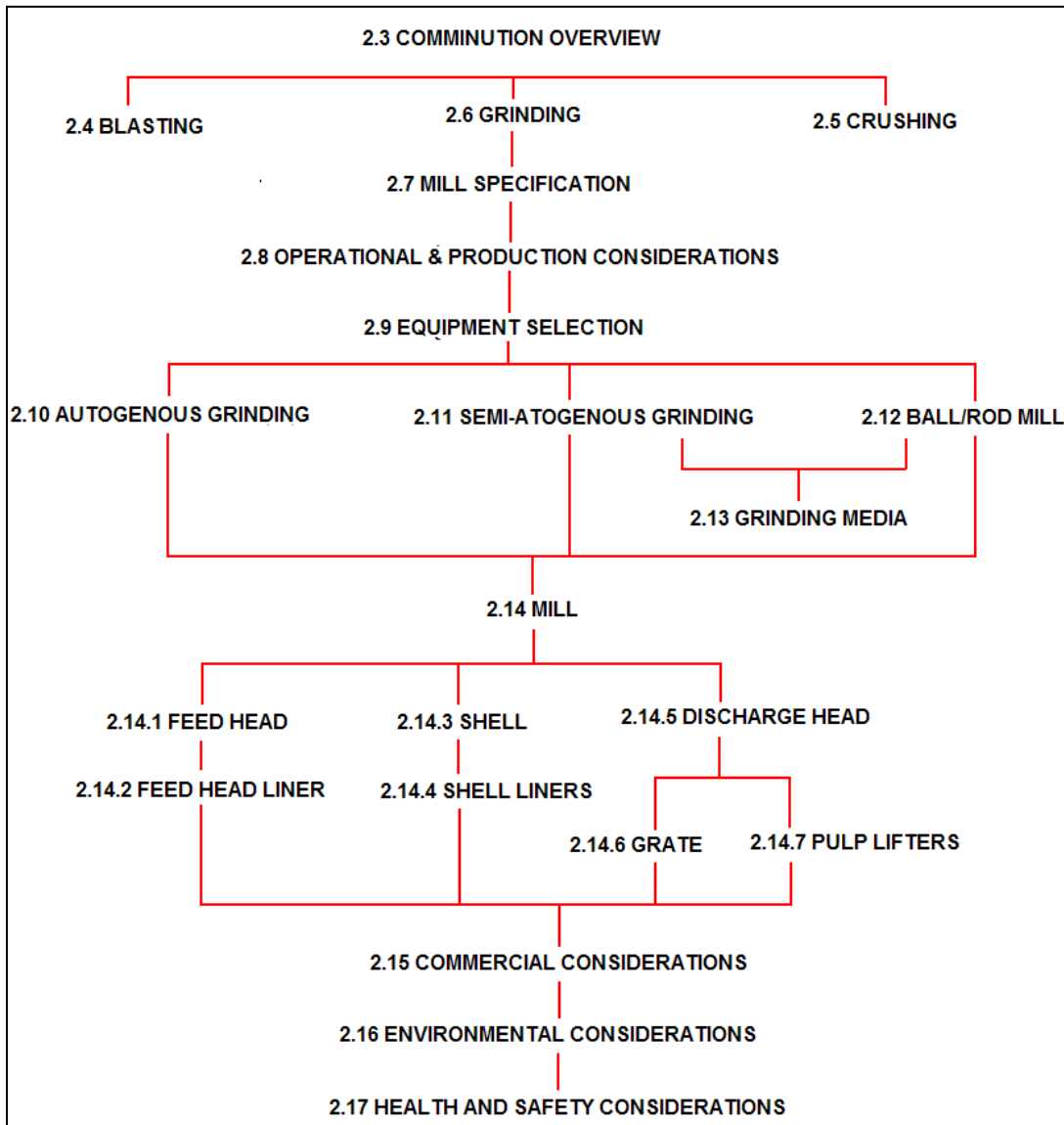

Figure 3.1: Comminution flow chart

3.3 Overview of the comminution process

Comminution marks the commencement the mining process and the first step in mineral recovery. Although the comminution process has undergone some amazing development at a micro-process level, on a macro scale of the industry has changed little since modern mining began. The three fundamental steps of comminution system remain essentially unchanged;

- Blasting
- Crushing
- Grinding

3.4 Blasting

The initial stage of comminution involves drilling an array of holes (determined by geological survey and ore body maps), loading explosives and detonation. The high gas pressures created from the explosive's combustion applies enormous forces on its surrounding environment, resulting in large and severe ground breakage. Particle sizes achieved are irregular in shape and range wildly in size (from small rubble to rocks up to several meters.) Blasting is a well established industry and highly efficient means of bulk ore reduction.

3.5 Crushing

The secondary stage of comminution is used to further reduce large ore to a suitable size for use with grinding equipment. Crushing typically occurs in stages, with each stage reducing feed-discharge size by three to six times. Primary crushing uses Gyratory and Jaw Crushers to reduce Run of Mine (ROM) and is capable of accepting feed ore as large as one meter in diameter. Secondary crushing equipment (Cone, Roll and Impact Crushers) further reduces primary discharge to sizes suitable for use with grinding equipment.

3.6 Grinding

The third stage in the comminution process uses a range of equipment to further reduce particle size. Typical grinding equipment includes tumbling mills, high pressure rollers and stirred grinding mills. By far the most commonly used being tumbling or rotating mills, which comprise of Autogenous (AG), Semi-Autogenous (SAG) and Media mills. AG equipment, unlike the other two types uses no added grinding media, while SAG, Ball and Rod mills uses some percentage of foreign media to facilitate size reduction. According to Han (2003), regardless of the type of tumbling mill, "particle breakage occurs by compression, chipping and abrasion" (resulting from the interaction between the ore, the media (where applicable) and the internal surfaces of the rotating shell).

Grinding is the least efficient process in the comminution circuit. Compared with blasting and crushing, grinding is highly energy consumptive. Mr Han notes when comparing the energy efficiency between various comminution processes, that a size reduction of 1000% can be achieved through a crushing circuit for as little as 1.0 kWh/t, when to achieve a similar size reduction in a primary grinding circuit will consume as much as 5-25 kWh/t.

Optimisation of the comminution circuit is essential to contain and where possible lower the impacts of these high energy rates. It is widely accepted within the mining fraternity that the design and sizing of the comminution circuit is the single most crucial system in establishing a cost effective mineral extraction process. The comminution process dictates the mining viability of an ore body and crucial to this circuit is an efficiently operating grinding mill. Whether at a design level or operation, the mill must be thought of as the "heart and soul of a plant's throughput capability" Starkey (2008)

3.7 Mill design and specification

At the preliminary design and cost evaluation phase of a prospective mining operation mill design is a central consideration. In most mineral recovery processes the mill is the single most expensive item of equipment, both in terms of *capital investment* at mine start up, or day to day operational expenses. Furthermore, a change to grinding equipment once installed has significant financial penalties. Incorrect specifications (diameter, length, capacity) cannot simply be altered without incurring major disruptions (and cost) to surrounding equipment, processes and production. As most mining operations use a single line¹ comminution circuit, any system shut down (for maintenance or modifications) will essentially cripple all further downstream processes while the circuit is off-line.

For this reason, mill specification is taken very seriously. Currently two major techniques are utilized by the mining industry to determine appropriate mill sizing:

- **Simulation-based methods:** This method adopts a more pragmatic approach to mill sizing by comparing the new 'ore sample' results with previously analysed samples from similar type mines (e.g. refer to an ever expanding data base of material/mining records.) Using analytical comparisons, suitable mill sizing can be recommended based on results obtained from other mines with similar ore body compositions. This system is quicker and cheaper than the alternate Power-based method; however it can have limitations exactly matching ore types and process methods to the existing database. For this reason *simulation* methods more frequently result in incorrectly specified mill sizing.
- **Power-based methods:** is a more comprehensive testing and evaluation process whereby a mill's "design is based solely on the ore body to be treated and not someone else's" Starkey (2008). The design method is aimed at evaluating each client's specific core samples to determine the 80th percentile of hardness variability. This ensures that 80% of the ore extracted and feed to the mill will be run at design speed or faster.

The above mentioned design systems aim to determine the physical size of the mill equipment and ultimately its production through-put capacity. The main factors considered when specifying a mill are detailed in section 3.8

3.8 Operations and production considerations

Critical to any effective mill design is a clear understanding of the operational parameters the mill will be designed to work to and the production expectations it must achieve. Significant areas of consideration are detailed from section 3.8.1 to 3.8.5

¹ Mineral extraction circuits are established as single or multi line circuits. A single liner circuit has only one grinding mill feeding further downstream processes. A multi line circuit has multiple mills positioned in series which can run either concurrently or alternatively.

3.8.1 Ore Hardness and Composition

One critical yet wildly variable system input is ore composition. It is arguably the single most influential design variable in specifying comminution circuit and yet also the least stable and constant. Due to the enormous cost of mine set up and in particular the mill and the comminution circuit, extensive drilling and ore body mapping is undertaken to determine ore variability across the intended mining lease. Unfortunately, as mines mature and leases extend or alter direction so to do ore compositions. Extensive core sampling prior to mill specification can significantly reduce impacts of ore changes however more frequently “mill optimization problems are caused by a basic misunderstanding about the magnitude of ore hardness variability and its effect on ... mill capacity and hence, plant capacity” Starkey (2008)

A range of mill system changes can be implemented to combat ore variability. Common examples of this are altering charge volume levels, mill speed or feed sizes. Due to the endless variability of ore compositions and mine production target, these changes are often site specific and reflect a pragmatic approach to mill optimization.

Ball and SAG mills have a further system adjustment over AG mills in that these circuits can also alter the percentage composition and size of the added grinding media to reflect changes in ore composition. As feed ores get harder, ball percentages can be lowered and ball sizes increased. Increasing the ball size and mass, increases the impact force produced as the cascading mill charge falls back into the field of breakage². This increased breakage force aids in improving grinding efficiency and the throughput of the mill, although mill operators must consider the adverse consequences of higher liner/lifter wear and impact damage (further development of this concept in section 3.14.4)

3.8.2 Speed

Rotational speed has an enormous influence on the operation of a grinding mill. This rotating speed has two primary functions on the operation of a mill.

3.8.2.1 Grinding Motion

As a mill rotates it shifts particles within the shell drum. This constant motion provides the catalyst by which grinding occurs. Figure 3.2 illustrates how rotational motion is imparted on the charge by using lifter bars bolted to the internal surface of the mill. The lifters act to key the charge to the mill wall. As the mill rotates this keyed charge rises to a point where gravity overcomes centrifugal forces and the keyed particles break from the wall and tumble down the charge face to the ‘toe’ where the process begins again. This continuous motion creates a frenzy of particle interaction which generates grinding in two ways:

² The terminology ‘Field of Breakage’ is used to describe the dynamically moving charge body that undergo short range tumbling motion due to the rotation of the mill. The field of breakage accounts for the majority of the mill’s grinding by attrition.

- **Compressive fracture** occurs when impact forces are generated between particles within the mill. The majority of this kind of ore fracture occurs when particles release from the mill shell at the break point³ and tumble/fall back to (or across) the charge body. Particles with lower breaking points have shorter falling distances and consequently lower impact velocities and compressive forces. Particles with higher breaking points generate significantly higher impact forces resulting in greater crushing/grinding capacity as illustrated in figure 3.2 below. Both the 'thrown' and 'tumbling' motion are crucial drivers of the grinding process.
- **Attrition** (a finer grinding action to compressive fracture) occurs due to particle motion within the charge body known as the 'field of breakage'. As the charge moves due to the shell's rotation, contents inside continue to have short range rubbing movements relative to adjacent particles. This constant movement coupled with frictional forces (generated from the weight of charge above) acts to chip and grind away at the particles. Attrition occurs throughout the field of breakage, but is most active at the toe and the break point (start and finish) of the rotation cycle when particles are most active.

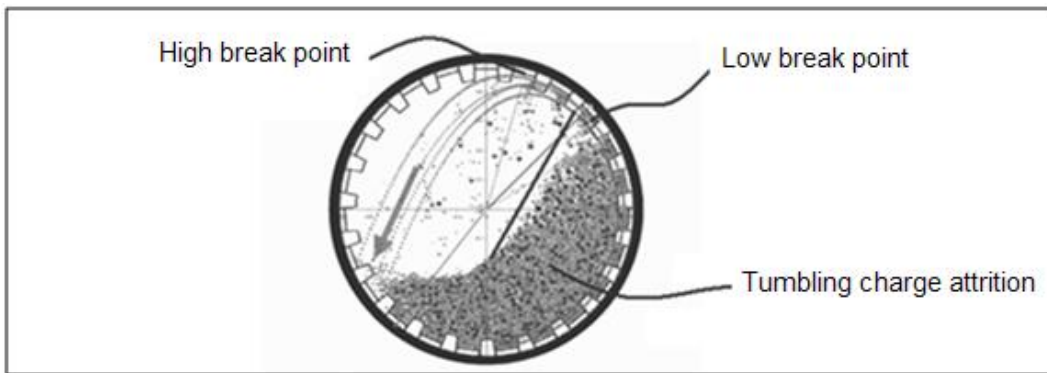

Figure 3.2: Charge motion (source: Principles of Mineral Processing)

The challenge for most mill operators is determining the speed at which grinding can be maximised whilst undesirable wear and impact damaged minimised. This is often a delicate operation, trying to increase thrown and cascading charge, without overthrowing it and risking direct liner/lifter impacts. Direct liner impacts may result in liner impact damage and accelerated wear and should be avoided to conserve operational life of liner.

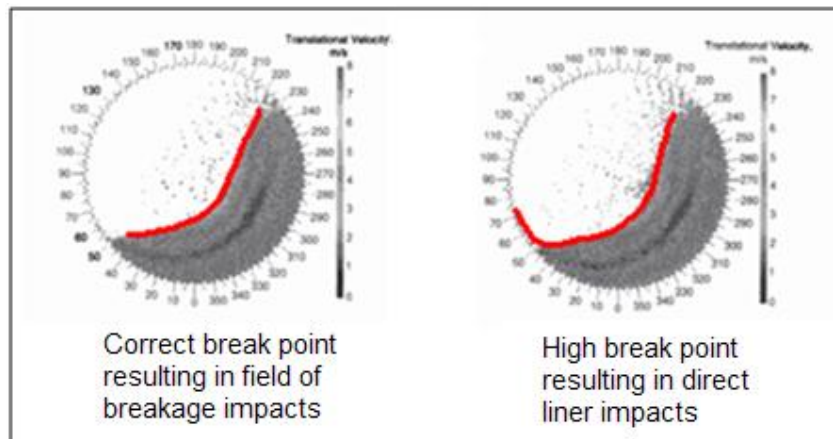

Figure 3.3: Charge break point (source: Principles of Mineral Processing)

³ The Break Point is defined as the point at which gravitational forces exceed centrifugal forces and charge particles fall from the mill shell during rotation.

Operators can fine tune the charge impact zones by adjusting rotational speed. The upper limit to this adjustment comes when critical speed is reached, at which point centrifugal forces exceed gravitational forces and the charge particles do not break from the shell and fall. This is a highly undesirable state and always avoided. Fortunately critical speed is well understood and easily calculated

$$\text{Critical Speed} = 54.19 \times (\sqrt{\text{mill radius}}) \quad (\text{note: mill radius units in 'ft'})$$

3.8.2.2 Discharge

The second main function of rotation speed is facilitating in pulp discharge. In mills which use a grate and pulp lifter system as seen in figure 3.4, pulp grind and small ore particles pass through the discharge grate and into the pulp lifter vanes. As the mill rotates the pulp and pebbles lift up and through the action of gravity fall down the vane walls towards the centre of the mill where it then discharges (refer to figure 3.5.) High rotational speeds (78-80% of critical speed) increase centrifugal forces and can limit the amount of pulp and pebble discharge in the lifters ending in carry over⁴. Slow rotational speed result in backflow. Both carry over and back flow significantly reduces the discharge efficiency of the mill.

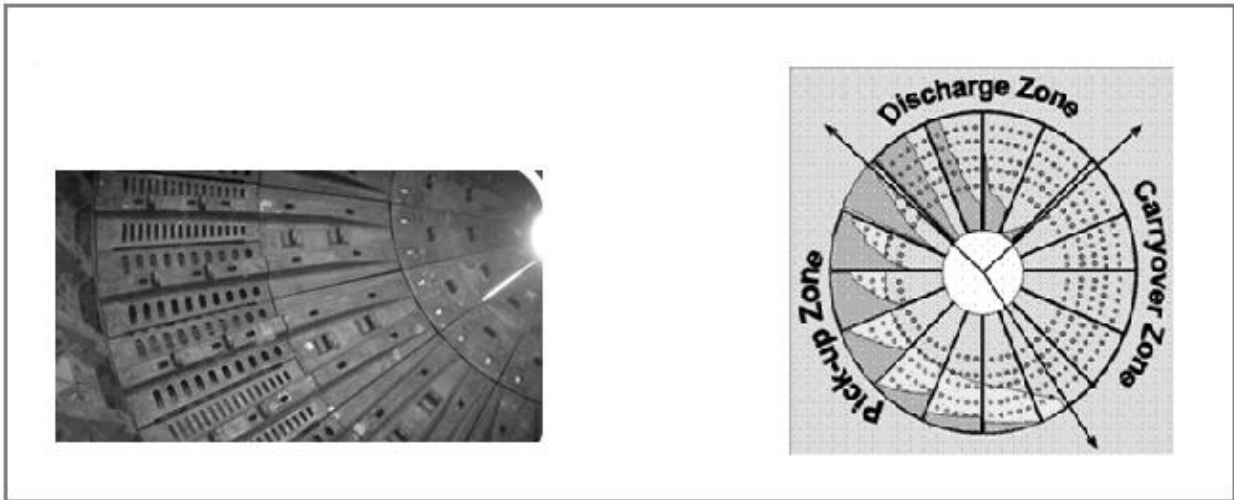

Figure 3.4: Grate and discharge head liner

Figure 3.5: Pulp discharge simulation (CW rotation)

⁴ Carry over occurs when pulp in the lifter doesn't discharge and remains in the lifter as it completes a full rotation cycle

⁵ Backflow occurs when pulp slurry already in the pulp lifter flows back into the mill through the grate

3.8.3 Throughput Tonnage

Production and Throughput are the terms you can be guaranteed that are being discussed at every mine's managements meetings and at every level. From ground level maintenance and operators to production supervisors and eventually by boardroom managers. The reason is simple. Mill throughput determines production output which heavily influences profitability.

Efficient operation of the mill's throughput is essential in optimising any mineral recovery process. At its most basic level, the mill can be divided into three fundamental systems:

1. **Feed rate:** This is the rate at which new ore (and if applicable grinding media) is introduced into the grinding mill
2. **Field of Breakage:** This is the engine room of the mill and its battery limits are from the feed trunnion to the discharge grate. In the field of breakage ore is reduced in size to a point where it can pass through the discharge grate. Motion within the field of breakage is always in the direction from feed to discharge, due to the self levelling nature of the liquid like charge filling the voids of pulp that has just passed through the grate and been discharged. For the system to be in equilibrium:

$$\text{feed} = \text{breakage} = \text{discharge}$$

3. **Discharge:** Occurs by either overflow or a pulp lifter method. Regardless of the system, this function removes ground ore from the field of breakage. This is an extremely important process to not only maintain flow equilibrium, but also to charge composition. As charge in the field of breakage reduces in size it begins to slurry pool and reduce the attrition and fracture performance of the mill. Efficient discharge is crucial to stable grinding performance.

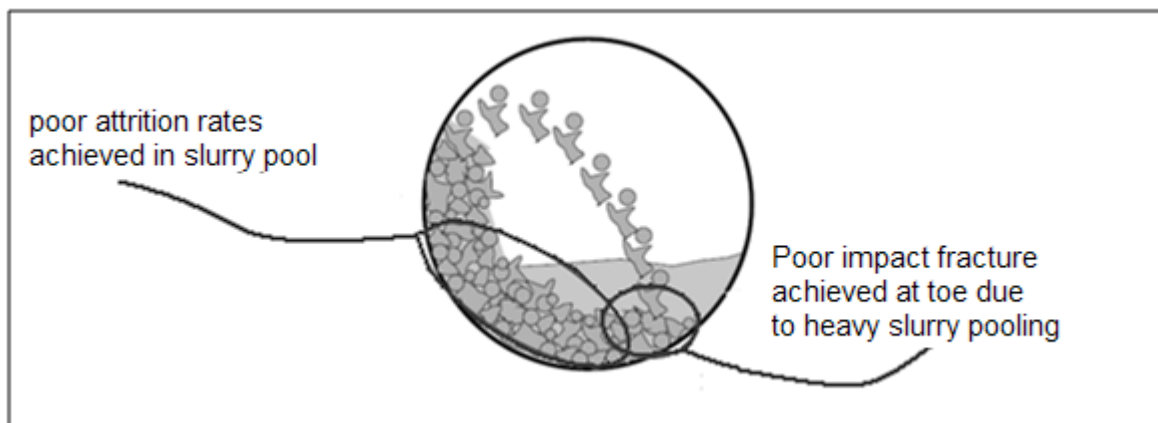

Figure 3.6: Pulp slurry pooling (source: Principles of Mineral Processing)

Mill operators can adjust system 1 (feed rate) in response to the performance of system 2 and 3 (field of breakage and discharge.) Numerous factors influence the performance and stability of systems 2 and 3. As mentioned in earlier sections, changes in ore composition (harder or softer) and changes to rotation speed or charge composition will alter the fee rate and ultimately the throughput. Other factors that can influence the systems are:

- Change to the liner systems
 - Change of construction material (steel to composite can alter impact characteristics and dead weight of the system.)
 - Change lifter configuration, height or geometry (changes to lifter configuration will alter the lifting capacity of the mill, the break angle and break point thus altering where thrown charge will impact.)
 - Wearing of the existing liners (as liners and lifters wear so too does the control of the charge.)
- Changes to grate and pulp lifter geometry (change of liner supplier or change from/to a straight or curved pulp lifter method)
- Upgrade power transmission system (upgrade to new ring motors or a dual pinion drive system will provide greater operating torque and greater mill operating volumes.)
- Changes to incoming feed sizes (crushing circuit upgrade or the introduction of a primary grinding circuit (AG mill))

These and many more variables can influence the stable operation of a grinding mill. Mills are continuously in a state of dynamic optimisation. Consequences of mill performance however are somewhat subjective to the extraction circuit utilised. For slower less process sensitive systems (like heap or vat leaching) production stability may not be the objective with a higher focus on maximum through-put. Other flow sensitive processes (like flotation) require constant throughput to stabilise downstream processes. Operators can utilise new technology to assist in optimising their mill's operation to the production required. Variable speed motors allow for real time dynamic adjustment coupled with new impact point audio technology, which track impact points “by the feedback of impact sound from microphones mounted close to the mill” Royston (2007). Operators can use this audio map to calculate the optimum drive speed for various operating parameters.

3.8.4 Operating Volume

In early mill operations mill volumes were constrained by the power transmission ability of motors, ring gears and trunnion bearing. With the advent of superior power transmission technology, mill operating volumes are now free to be altered to assist with production optimisation. As with any rotating device the greater the mass centre distance from the centre of rotation the greater the torque and the power required to run the machine. This concept can be extended to that of the rotating mill. Low operating volumes, coupled with the high dead-weight of the mill shell and shell liners results in a high power consumptive and inefficient operating system. Conversely, as volumes increase, the mass addition doesn't uniformly distribute around the peripheral of the mill but rather moves towards the axis of rotation. This closer mass centre

profile aids in a more efficient power consumption yield for the mill and ultimately a higher volumetric field of breakage.

Mill operators use volume as a system variable to balance out other input changes. Harder ores require greater concentrations of grinding media (mill balls) and or size. This increase can be accommodated by altering the operating volume of the system. Like all system changes with a mill's operation, changes need to be documented and analysed against performance and efficiency to determine an appropriate course of action for future conditions.

3.8.5 Wet or Dry Grinding

Wet or dry grinding is generally determined at the design stage of a mining circuit. Some applications are not suitable for wet grinding due to chemical composition, or down stream processing systems. Most mineral applications are however are suitable to wet grinding and consequently it is often the system adopted.

Wet grinding generally occurs at 65%-75% solids by weight. The liquid, which when combined with fine ground ore creates a liquid pulp. This pulp creates of a pressure gradient within the field of breakage that facilitates a liquid like flow of other particles and fluid towards the grate. Further to this, the fluid pressure gradient drives fluid pulp and pebbles that are small enough to pass through the grate and into the pulp lifters. This discharging action is fundamental to the performance of the mill.

It should be noted that the introduction of water to the system is not all positive and need to be carefully regulated. Higher liquid content may result in 'packing' between lifters. Packing is the result of pulp filling and compacting in the void between the shell liner lifter. This can occur for a variety of reasons, however when it does occur it has disastrous implications on the mill's lifting efficiency and consequently results in an underperforming field of breakage.

Other adverse outcomes include slurry pooling and backflow which were discussed earlier.

3.9 Equipment selection

Development of horizontal milling equipment has been a rapidly developing and highly competitive industry. Equipment suppliers are continually utilising new manufacturing technologies to improve and differentiate their mills for their competitors. This said (and with all the fine differences) the majority of mining organisations around the world now use one of three principle types of milling equipment. This section aims to define these mill types and explore applicable machine components.

3.10 Autogenous mill

Autogenous (AG) grinding mills are the largest of all horizontal rotating mills with size currently reaching 40ft plus. Unlike Semi-Autonomous and media mills (ball and rod), AG mill use have no externally added grinding media to facilitate grinding. All fracture and attrition size reduction occurs as a result of interaction between the ore in the mill. Due to the lack of grinding media, AG mills require large diameters to generate the impact speed from thrown charge and greater tumbling surfaces to provide particle breakage. Common AG mill dimensions have diameter to Length (D/L) ratios of 2:1

AG mills are typically fed use Run-Of-Mine (ROM) ore which comes directly from the mine (with little or no crushing.) As a result, AG mills require large feed end (FE) trunnions to facilitate the larger feed stock sizes. AG mills typically have higher wear patterns as the milling environment is less stable and controlled (e.g. wide ranging feed stock, and internal volumes can fluctuate.)

Ag mills are generally used in two applications. Firstly as a primary grinding circuit to reduce feed size before being fed into a secondary grinding system like a ball mill. This system design would be applicable for a high production circuit that is process sensitive.

Secondly, AG mills are used for applications where high volume through put is required. Examples of these types of processes would be a large gold or copper mine using a heap or vat leaching processing. These processes are not terribly grain sensitive and can efficiently work with a wide ranging ore size.

AG mills are large and very expensive pieces of equipment which require the largest available motors to drive the enormous loads.

3.11 Semi-Autogenous mill

Semi-Autogenous (SAG) Mills are similar in many respects to AG mills. Their size, cost, energy consumption and feed are all very similar. SAG mills however bring the high volume benefits of AG grinding, but with the out-put size control of a ball or rod mill. SAG mill are often utilised as dual purpose grinding devices combining the benefits of AG and media style mills into the one device.

SAG mills achieve this hybrid result by utilising the dimensions of AG equipment, but with the addition of 10-20% of grinding media (mill balls) by volume. The grinding media offers the highly effective ball-ore-ball size reduction capacity, while due to the sheer size of the mill, high velocity ore-ore impacts provide a significant contribution to fracture reduction. In addition, the field of breakage is significantly larger than a standard ball mill, therefore grinding due to tumbling attrition offers very productive mid to small range grinding.

SAG mill are expensive to buy and expensive to run. They consume an enormous amount of power due to the large diameter drums. Also, liner wear and impact damage is more prevalent

so consequently larger and more robust liners are used. These liner/lifter plates have a significant replacement cost adding to the high capital maintenance of the mill.

This said however, the benefits often outweigh the negatives. SAG mills have been very successful at providing the intermediate mill to not only set-up high production mineral recovery circuits, but also optimise system stability with reliable out-put size and tonnage rates.

3.12 Ball and rod mill

Media style mills like ball and rod mills are used to produce controlled out-put grain sizes. Unlike AG/SAG mills they have a greater length than diameter usually in the order of 1.5 times longer. This additional length ensures the field of breakage moves slowly along the mill producing well ground and consistent pulp. Ball mills typically are used for flotation, gravity and magnetic processing circuits, where controlled grain size is crucial to high mineral recovery rates.

Ball mills generally run a high grinding media concentration (40%-50% by volume) and can reduce ore to sizes as small as 100µm. Although much smaller than AG and SAG equipment, ball mill are still expensive and highly energy consumptive. Due to the finer grinding requirements and the higher percentage of grinding media in the mill, charge ball mills are expensive to run. Operating costs divisions are “media accounting for over 57% of the total milling costs, energy 25.5% and the liner around 17%.” Walker (2010).

3.13 Grinding media

According to Han (2003) in SAG and Ball milling equipment “Communion occurs predominately from ball to ball or ball to liner events causing particle fracture”. Due to the importance of the grinding media in size reduction there is now a range of grinding materials available to the milling industry from steels and alloys to ceramics. Sample batch testing can be used to determine optimum grinding media, but in most mineral extraction processes steel is used simply for its lower cost per kilogram.

Traditionally ball sizes were used from 75-104mm, but now with the installation of larger AG and SAG mill equipment, mill balls can be found as large as 152mm (6”).

Ball wear is a major operating cost to any communion circuit. Within the industry it is frequently accepted that AUS\$1 of grinding media will be consumed for every tonne of mill output. Wear and consumption of the grinding media is a function of two separate operations:

- Cutting wear by abrasive particles. This abrasive wear occurs predominately through ball to ore impacts (necessary to break the particles) and results in small cuts in the surface of the ball. Increasing the hardness of the ball reduces the metal loss to abrasive cutting.

- Plastic deformation. This wear occurs as a result of high load impacts on the ball. Generally this is attributed to ‘ball to ball’ or ‘ball to liner’ impacts. These impacts result in high localized stress zones and the formation of white layers on the surface of the balls. Experimental results have concluded that “High carbon steel exhibits more wear loss than low carbon steel” Zheng (1997) Wear occurs from delaminating of the white layer from the ball’s surface and “it may be concluded that wear resistance of material under high stress impact is related to the white layer” Zheng (1997).

3.14 The mill

The mill comprises of three main parts:

- The Feed-End Head and the FE Trunnion
- The Shell
- The Discharge-End Head and DE Trunnion

All three once assembled create the grinding mill.

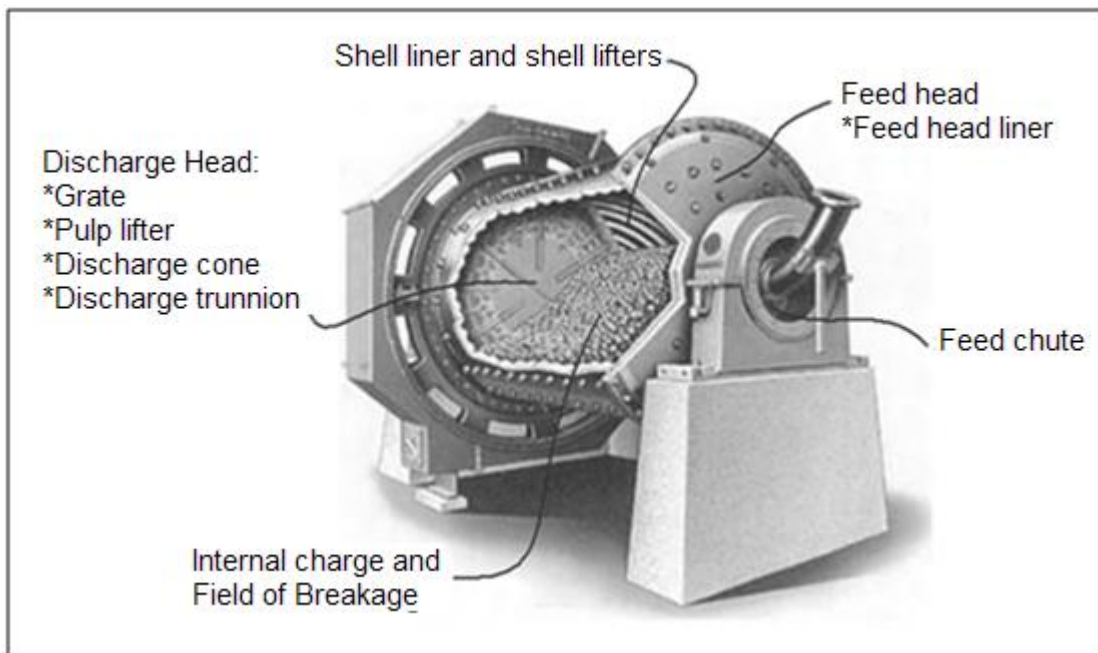

Figure 3.6: Mill component identification (source: Principles of Mineral Processing)

3.14.1 Feed head

The feed head is a single cast or fabricated conical end plate. Concentric to the feed head is the feed trunnion where new ore and grinding media is introduced into the mill. Traditionally a running bearing support would be mounted to the feed end trunnion as shown in figure 3.6, however due to the increasing size and weight of AG and SAG mills, more recently shell

supports are used at the feed head-shell transition. Locating the support on the shell peripheral has reduced buckling stress and cyclical fatigue failure in the feed trunnion.

3.14.2 Feed head liner

The internal surface of the feed head is covered with replaceable liner and lifter plates. The plates (which are described in detail in the following section) protects the feed head shell from impact damage and wear.

3.14.3 Shell

The shell is the large cylindrical drum that spans the distance between the feed head and discharge head. Motion drive imparted on the ring gear is transferred through the entire mill via the shell. In addition the shell holds the charge and produces the grinding environment for ore reduction to take place.

3.14.4 Shell liners

Due to the abrasive nature of grinding, all internal surfaces of the mill require protective coverings to avoid damage and premature failure of the shell structure. Shell liners provide two main functions in relation to the comminution process:

- 1) To produce a ***motion key*** between the charge and the rotating mill. This motion key is produced by the shell lifter geometry which is a raised rib profile running along the length of the lifter (and longitudinal to the mill's axis of rotation). The elevated rib (which can vary in height and angle) acts as a lifting face, creating a ledge on to which the ore rests. Centrifugal forces during motion anchor the charge to the internal surface of the liners until gravity exceed centrifugal forces and the charge releases (break point), cascading down onto the charge surface below.
- 2) ***Wear protection***. Liner wear can occur in two ways:
 - ***Impact wear*** resulting from impacts created when falling/cascading charge particles impact the toe of the field of breakage as illustrated in figure 3.3. Forces created from ball-ball impacts are absorbed by the shell liner. Additionally and more destructively, high impact stress wear occurs if the thrown charge has too much momentum and overshoots the charge toe directly impacting the liner. To preserve shell liner life "over shooting should be avoided, especially high-energy ball-on-shell impacts just above the charge toe, owing to the risk of ball-on-liner damage and excessive metal flow." Han (2003). This point is particularly important when considering the severe damage resulting from ball to liner impacts and the small grinding value that thrown charge adds to the comminution circuit. According to Royston (2007) "much of the rock breakage throughout the liner life must come from the tumbling and not the

thrown action, i.e., rock breakage through repeated short-range impacts, attrition and abrasion”

- **Abrasive wear** results from charge sliding across the liner and lifter’s surface. This occurs in the following ways:
 - When a particle which has just cascaded down the charge face returns to the charge-toe to commence a new rotation, it will momentarily bounce around until it is secured by other charge particles ready to rotate up the shell wall again. This erratic motion coupled with small ground ore particles creates minute micro-cuts in the liner surface. This continuous action coupled with the above mention impact wear has a substantial influence of a liner’s operational life.
 - Sliding as particles break away from the shell liner and cascade down the charge face. The abrasive action is similar in nature to the toe abrasion described above.
 - Due to slippage from insufficient charge-lifter key. This typically occurs from either packing or worn lifter.

3.14.4.1 Liner/lifter design

Shell liner design is one of the most active areas of mill engineering. Liner manufactures and mill users continue striving to optimize liner efficiency within the grinding circuit by extending the service life of lining components while increasing production rates and reducing operating costs. New design and simulation software packages (notable Discrete Element Analysis packages like ‘milltraj’ and ‘millsoft’) have enabled manufactures and design engineers to explore vast combinations of liner configurations, mill sizes and operating speeds to maximize grinding efficiencies. This new technology has enabled simulated testing without the prohibitive costs associated with tooling manufacture and in-situ testing. Some of the main areas of design development are:

3.14.4.2 Construction materials

Traditional construction materials like carbon steels and bisaloy are in many cases being substituted for alternatives including a range of polymers and elastomers (natural and synthetic rubbers, Polyurethanes and Ultra High Molecular Weigh Polyethylene UHMWPE), ceramics and alloy steels (austenitic manganese, and chrome-molly steels). Recent trends have seen developments in composite liners, combining a range of these materials into one homogenous lining plate (rubber/ceramic plates or rubber liners with replaceable steel lifters.)

3.14.4.3 Grinding participation

Engineers have long been aware that improved grinding efficiency is achieved by increasing charge participation rate. This is achieved by increasing charge lift per rotation and mill speed

(the faster the mill rotates the more charge tumbles per revolution.) The challenge has been to do this and maintain control over the charge and discharge efficiency, considering that a higher rotating speed reduces discharge efficiency.

Charge motion is particularly affected by changes to mill speed. A faster rotating mill will result in a higher break point and overthrown charge. To achieve better control over the charge engineers continue to alter liner and lifter geometries. This has been achieved by adjusting three independent variables: height, angle and spacing.

Increasing lifter height increases the lifting volume of the mill. The **bucket** (which is the volume between each consecutive lifter) is essentially a function of the lifter's height and the circumferential spacing between the two consecutive lifters. Traditional lifter spacings used a 2D ratio of internal diameter measured in feet. This meant a 40' internal mill shell would typically contain 80 lifters. With developments in liner construction materials and changes to lifter profiles, current trends have been to reduce the number of lifters thus increasing the bucket volume between them (sometimes to as little as 1D but generally to a 4/3D ratio). This reduction in lifter quantity has conversely allowed an increase in its height. The net result has been an increased mill action and greater lifter impact strength (due to its increased thickness of the liner and the lifter).

Royston (2007) states that control of this increased charge lift can also be achieved by changing lifter angles. "*Changing the face angle* of shell lifters alters grinding ball trajectory, and hence the point of impact within the mill". By utilising computer simulated modelling programs, design engineers can now trial numerous combinations of height, angle and lifter spacings to identify the optimum predicted liner system. Consideration of the consequences of increasing and decreasing lifter spacing should be thought through during model simulation.

Firstly although **increasing spacing** produces greater charge lift, production and higher lifter impact strength, the larger space now produced between the lifters makes this liner surface more susceptible to impact damage from direct charge impacts. Mills with higher lifter ratios (like 2D) generally experience some degree of packing (compaction of small charge particles between lifters) and as such have a renewable liner protection. With lower lifter spacing however packing is unlikely to occur. When these liner faces experience particle bombardment, they can fracture or prematurely wear with catastrophic implications for the mill shell.

Additionally, wider lifter spacings have deleterious effect of dispersing the thrown charge which results in difficulty focusing the cascading charge onto the toe impact zone (contributing to the above mentioned liner damage.) Finally, too wide a bucket may result in charge slippage during rotation, counteracting the benefits of increase bucket volume and resulting in accelerated abrasive wear to lifter faces.

Determining the optimal liner lifter design often requires a degree of trial and error. To refine charge control the operator may increase the number of lifters however this inherently results in 'packing'. Packing occurs when the lifter angles are too square, bucket spacing too narrow or a combination of the both. Packing reduces both lifting capacity and charge control. This can have

a catastrophic result on wear to lifter faces and severe losses in mill action if it is not considered and planned for. Alternatively, with good design, packing can be used as a type of impact fender, shielding exposed liner faces from harmful ball impacts.

Changes to ***lifter sequencing*** have recently yielded some promising results. By combining a Hi-Low lifter sequence (as opposed to a traditional Hi-Hi) operators have been able to capitalize on increased bucket volume while alleviating the slippage problems associated with it. Further developments in lifter sequencing are the double faced lifter bars which facilitate dual direction rotation of the mill (thus lengthening the maintenance period before re-lining is required.)



Figure 3.7: Liner and lifter configurations (Source:

[http://www.metso.com/miningandconstruction/MaTobox7.nsf/DocsByID/15237F7DC245FBCFC22576C500426A0F/\\$File/Product_range_mill_linings_English.pdf](http://www.metso.com/miningandconstruction/MaTobox7.nsf/DocsByID/15237F7DC245FBCFC22576C500426A0F/$File/Product_range_mill_linings_English.pdf))

Source:

3.14.5 Discharge head

The discharge head is the symmetrical inverse to the Feed Head although some of its lining and internal bolt on additions differ in operation and configuration to the feed end of the mill. The 'Discharge Head' provides a second cylinder end to encapsulate the mill charge inside. As the name suggests however, the DH regulates the discharge of ground ore pulp and pebbles from the mill. The discharge mechanism is configured in one of two ways.

- 1) **Overflow:** This method of discharge is generally used for lower throughput milling systems and is typically used in ball mills. The mill is configured with a slight fall as seen in figure 3.8 so that ore will spill out the discharge trunnion at an equivalent rate to incoming feed. As there is no mesh screening during discharge, particulate size control is diminished. Typically this style of mill would require external particle grading and a return circuit to re-enter oversize ore and mill balls that discharged.

Overflow systems are simpler and cheaper to operate than 'Grate Discharge' systems however they have noticeable limitations regarding mill capacity and higher production rates.

- 2) Grate & Pulp Lifter: Current milling trends have been towards the use of a Grate and Pulp Lifter discharge system (which will be discussed in detail in the following sections.) The shift to this systems has been driven predominately by two production requirements:
- a. Improving pulp discharge particulate size control.
 - b. Improved production and through-put control.

Operators using grate discharge mills are more likely to produce consistent ore grades and predictable and stable production rates than using an overflow discharge system.

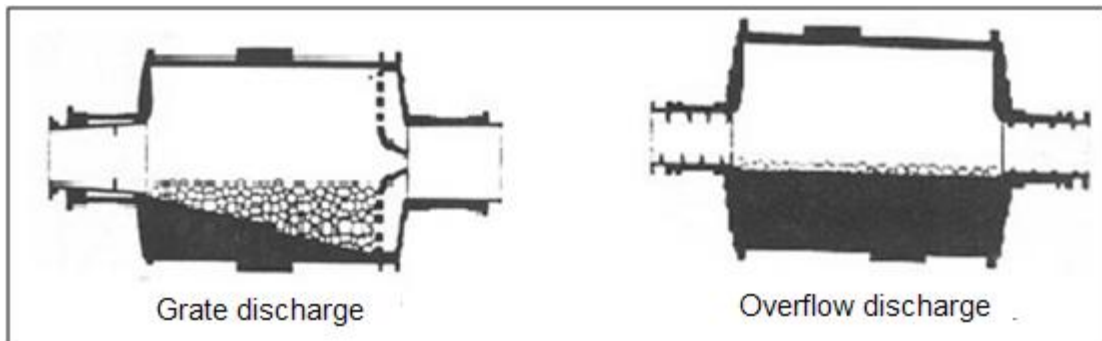

Figure 3.8: Mill discharge(Source: <http://miningbasics.com/how-overflow-discharge-ball-mill-works>)

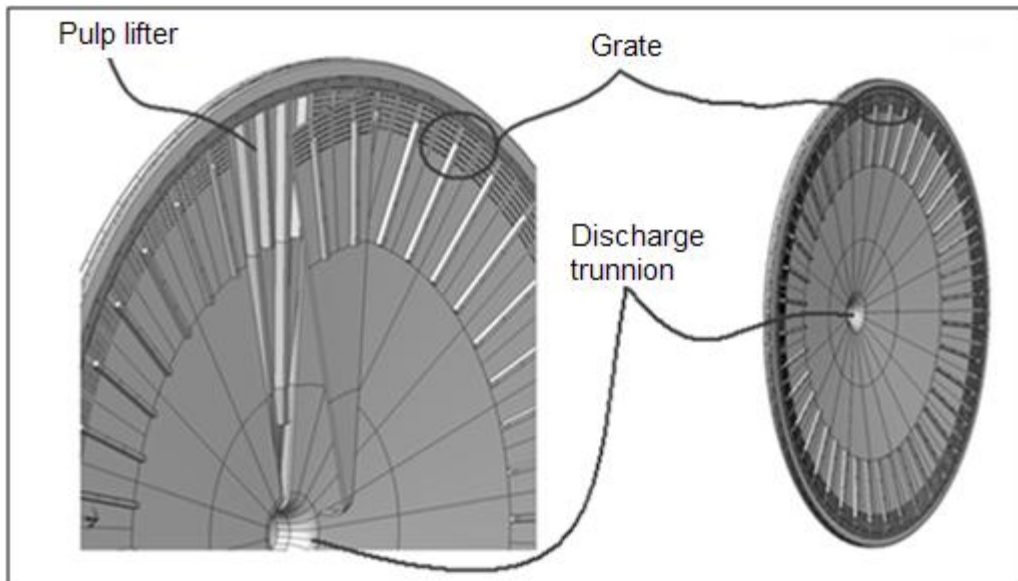

Figure 3.9: Component identification for grate discharge

3.14.6 Grate

Grates are large flat steel plates which are bolted to the Pulp Lifters as seen in figure 3.9. The grates and accompanying end liner plates restrict the flow of charge ore from entering the pulp lifters until it has reduced in size to the required grading. Pulp once at this grading can then pass through a series of holes cut in a circular array around the peripheral of the end plates. *Location, quantity and size* are critical operational parameters for effective grate design. To avoid wear, grate openings must be outside the eye of the charge⁶ which is the almost stationary centre of the field of breakage where little or no motion takes place. Grate openings if located within the eye undergo rapidly accelerated wear due to the inconsistent speeds of the stationary charge and the rotating end plates. The challenge then becomes to provide sufficient grate openings outside the eye to transfer pulp and pebbles at an equal or greater mass rate than the feed (otherwise the system will not be in equilibrium.) Achieving an equivalent flow opening whilst restricting grate hole sizes (to grade pulp) is a complicated design trade off, particularly for mill's designed to operate at high rotational speeds (which have less time for the pulp to flow through the grates during Zone 1⁷.)

Further complicating grate design is the objective to minimise backflow from the pulp lifter. This operational deficiency was identified in section 3.8.2.2 and is a major cause of system instability for the grate and pulp lifter discharge system. Figure 3.10 illustrates the filling and discharge cycle. During Zone 1, pulp slurry flows through the grate into the pulp lifter. As the lifter rises above the slurry pool level into Zone 2⁸, much of the pulp is still stationary, pinned by centrifugal forces to the outer peripheral of the pulp lifter vane. Only once the pulp lifter has rotated past the horizontal does the pulp start to level out in the lifter and commence moving towards the discharge trunnion. During this levelling phase, the pulp within the lifter can flow back through the grate into the mill due to hydraulic pressure created from the centrifugal forces.

Backflow reduction can be achieved in a number of ways:

- 1) By reducing mill rotational speed, the pulp levels quicker and moves towards the discharge trunnion.
- 2) Moving grate openings higher above pulp lifter vane walls creates a greater holding volume in the pulp lifter.
- 3) Using curved pulp lifters vanes (which will be discussed in the next section.)

⁶ All rotating mills have a charge eye which can be thought of as the centre of rotation of the elliptical shaped field of breakage. One side of the field is moving upward through the influence of the lifter key while the othersider side of the eye is tumbling downwards in the opposing direction.

⁷ Zone 1 will be used throughout the remainder of this report to describe the filling segment of the rotating mill

⁸ Zone 2 will be used throughout the remainder of this text to describe the lifting segment of the mill where backflow occurs.

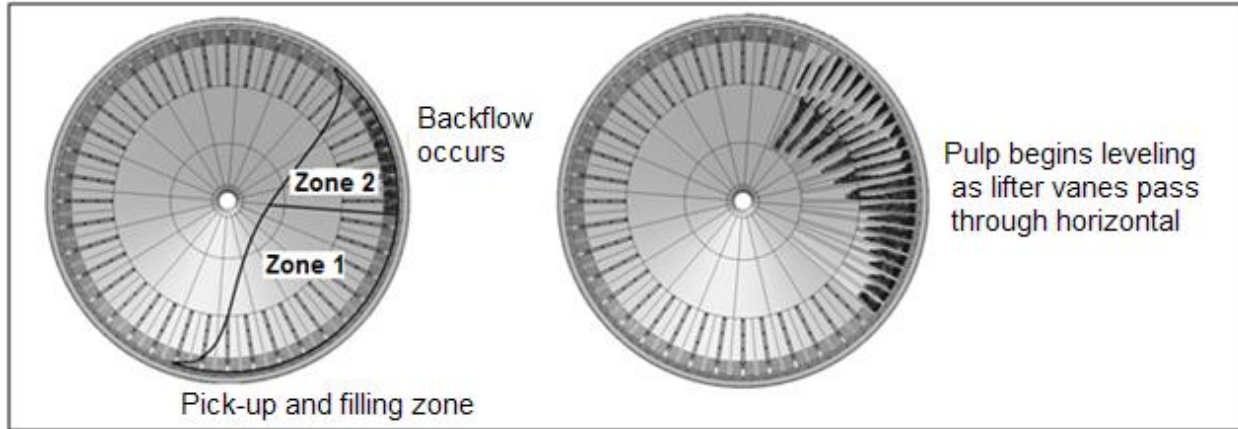

Figure 3.10: Pulp filling and backflow motion

3.14.7 Pulp lifter

Pulp lifters are located directly behind the grate and provide two distinct functions:

- 1) Wear protection for the discharge head from pulp and pebble motion.
- 2) A discharge mechanism to remove pulp and pebbles from the mill: The pulp lifters are narrow radial vanes connecting the discharge head trunnion to the outer shell peripheral and the grate holes. The vanes fill with pulp and pebbles (which pass through the grate during 'Zone 1') and are then lifted through the mill rotation (Zone 2) to a point where gravity exceeds centrifugal forces and the pulp slides down the pulp lifter vanes into the discharge trunnion (Zone 3). This process is illustrated in figure 3.11 below.

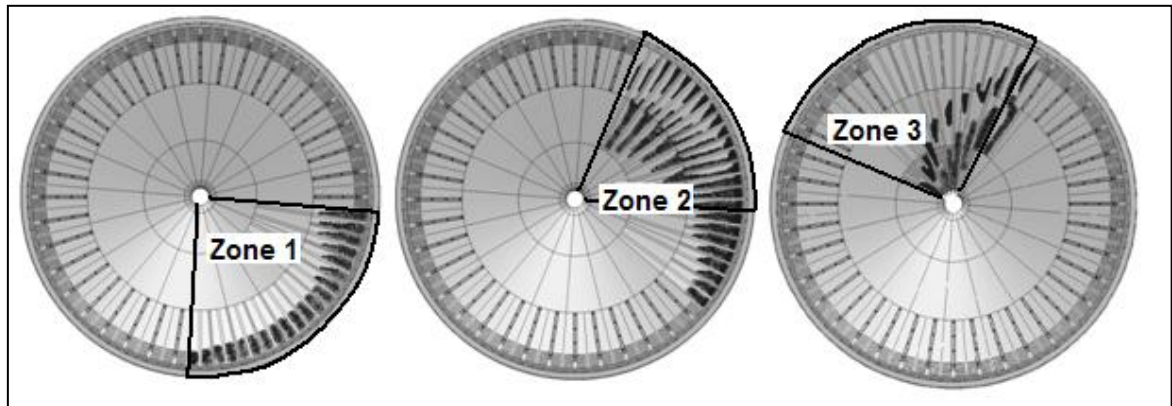

Figure 3.11: Pulp motion during discharge

Pulp lifters are essentially a rotary pump with a twist. The pump uses a combination of centrifugal forces and gravitational forces to fill and then discharge the lifter vanes. As a result, the efficiency of the pulp lifter mechanism is influenced by the rotational speed of the mill. While lower angular velocities decrease the grinding efficiency of the field of breakage, higher rotating speeds increased (especially as they approach the critical speed) the centrifugal forces

imparted on the pulp and pebbles in the lifter vanes, cancelling the purging effect of gravity and limiting the lifter's ability to fully empty the lifter's contents during a rotation.

Carry-over is the result when the lifter's contents don't completely empty. Carry-over is undesirable for two reasons:

- 1) Carry-over reduces the efficiency of the mill discharge system as the pulp and pebbles that were carried over then return to the peripheral of the lifter vane and limit the pumping capacity of the vane for the next revolution.
- 2) Increase abrasive wear results from carry-over pulp sliding back down the lifter vanes.

The constant push to raise grinding production output (often achieved through increasing mill speeds) has led to some innovative and effective pulp lifter design developments. Of note is the 'Curved Radial Pulp Lifter'. Unlike the straight radial lifter the vane curves like a hockey stick as it approaches the shell peripheral. This curving produces strong inward directed centrifugal forces and momentum, shifting the pulp away from the grates and towards the discharge trunnion. The design has had great success in decreasing 'Backflow' as the pulp is quickly shifted away from the grate openings prior to leaving Zone 1, as well as efficiently emptying lifter vanes even at speeds close to 'Critical'.

The curved radial has a major operational disadvantage however. Due to its curved vanes the lifters can only operate in a unidirectional rotation. This presents a significant operational maintenance cost penalty, stemming from the inability to alter rotation and evenly wear both sides of the internal shell liners (which is growing cost saving trend in mill equipment operation.)

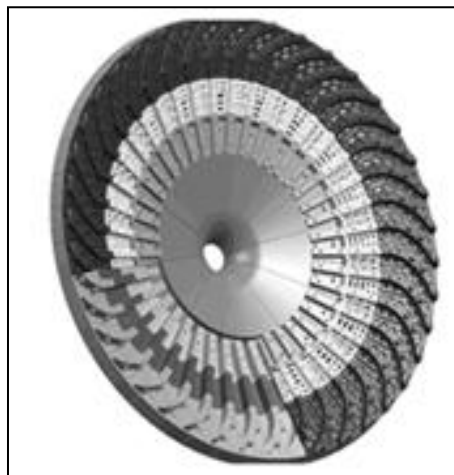

Figure 3.12: Curved radial pulp lifter (Source: <http://www.bradken.com.au/our-divisions/mining/mineral-processing/product-range/grinding-mill-liners.aspx>)

3.15 Commercial considerations

Mining is an expensive and often high risk operation. Financing and operating mines require big budgets and tight cash flow control. The industry is riddled with stories of BIG OPPORTUNITIES that fail to materialise because of financial difficulties. Like all large capital intensive industries, mining requires:

- good planning
- good research

and

- good execution.

The following section aims to highlight these key commercial considerations and their implications of a financially stable mining operation.

3.15.1 Capital and setup costs

Without question the most expensive phase of any mining operation is setup. This comes directly on the back of exploration, which is a massive up-front cost in itself with no guarantee of locating a commercially viable resource deposit. If exploration does however locate a reserve, the mine then must undergo the expensive and time-consuming process of set-up.

Depending on the mine, its location and size, this can take several years to complete and at costs well into the billions of Australian dollars. During this exploration, set-up and construction phase no income is generated so balance sheets are often very unstable, except for a few large and well-capitalised miners.

It is well acknowledged within the mining industry that the set-up of the crushing and grinding circuits is one of the most expensive systems to establish and often runs into tens of millions of dollars. Coupled with the fact that at this point the only ore data available are the sample cores from exploration drilling, the operational and commercial set-up risks are exponentially multiplied. As identified in earlier sections specification of the comminution circuit is highly speculative and often results in incompatible systems that require costly modifications and alterations.

3.15.2 Production

Once established the comminution circuit becomes the focal point of any mining operation. Until the comminution circuit is running efficiently little or no focus will be spent on other downstream processes. "This is because the energy-intensive comminution operations use on the order of 50% of a mineral processing plant's operating costs" Han (2003). In particular and due to the higher energy required for fine grinding, rotating mills use the highest percentage of this energy and often run at less than 5% energy efficiency.

3.15.3 System configuration

Involves adjusting operating variables to continuously improve grinding efficiency. In early mine operations efficiency will typically be low, as little or no comparative data will be available to benchmark the system to. Referencing similar operations elsewhere is a useful start, however

due to ore variability and different production requirements; rarely will the setup be identical. Operators are tasked with quickly configuring the comminution circuit to initially ensure reliable feed to downstream processing and then to minimising operational production costs.

3.15.4 Consumables

Grinding consumables consist of grinding media and internal lining parts including shell and head liners, grates and pulp lifters. Mill consumables are a major operational cost to any mine, and improving system efficiency and ultimately production tonnage per consumable dollar input is a high priority. According to Han (2003) in America alone, “approximately 500,000 tons of steel is consumed in media, liners and other wear parts” each year

- **Grinding media:** Grinding media consists predominately of balls and rods, which are used to improve size reduction by increasing fracture forces and attrition rates in the field of breakage. Depending on the mill and ore type anywhere from 5-40% of charge volume could be added grinding media. Grinding media adds on average AUS\$1 of grinding consumable cost for every tonne of ore through-put.
- **Liners:** “Mill liners provide the replaceable wear-resistant surface within grinding mills; they also impart the grinding action to the mill charge” Royston (2007) Conservation of mill liners is a high priority for a diligent mill operator as replacement cost and production losses due to maintenance shutdowns represent significant cost to a mining operation.

3.15.5 Maintenance

Maintenance is a major operational cost for every mining operation. Mill equipment in particular requires expensive periodic maintenance in the form of internal relining, where old and worn liners are removed and replaced with new parts.

3.15.5.1 Maintenance planning

Maintenance planners have a large responsibility to ensure replacement parts are on site and ready for installation when required. This can be a delicate balance especially for small less capitalised operations considering the significant cost of replacement components. Of note are electric motors, pinions and ring gears, bearings, shell liners, grates and pulp lifters. Combined several millions of dollars could be warehoused in the event that they may eventually be required.

The *Loss Of Production*⁹ penalties must be weighed against cash flow tie down for the maintenance planner in determining what parts to order and have available in the event of unplanned maintenance. Downtime is a critical factor, particularly for mines that rely on a single large mill for primary grinding and in these cases could represent loss of many hundreds of thousands of dollars for each day that their mill is not operational.

⁹ Loss of Production refers to all of the lost production revenue resulting from a shut down circuit.

3.15.5.2 Programmed maintenance

Programmed maintenance is the preferred method by which mine operators prefer to shut down their milling. "Stopping a mill is a very expensive operation," Gill (2005) and is generally avoided unless a scheduled shutdown has been planned for.

When these shuts do occur, typically all aspects of the equipment is services, but the single most time and cost intensive of these tasks is liner replacement. For an 18MW SAG mill "a reline takes about four days to complete at a cost of \$1.5 million" Walker (2010). Coupled with loss of production it is easy to see why liner preservation is a serious focus for mill operators. Operational procedures like dual-direction rotation or new technology 'On-Grind Audio Sensing Equipment' aid in extending the operational life of milling consumables. The double whammy of reduced replacement costs and fewer shut downs adds significantly to operational profitability.

When re-lining is required however, careful planning must go into the event. Maintenance engineers must ensure the correct liners have been ordered, are on site and all additional fixing requirements for the replacement are readily available. In addition, specialist re-lining crews need to be booked and mobilised to site ready for the shut-down. Additional re-lining equipment needs to sent to site as required. Recent trends in re-lining have seen a shift to using hydraulic re-lining equipment which can safely handle heavy lining plates within the confines of the mill.

3.16 Environmental considerations

Social responsibility requires all business to take steps to reduce carbon emissions and ecological footprint of mining operations on the environment. Relating directly to grinding equipment this can be achieved in a number of ways:

- Improving the efficiency of milling equipment reduces the energy per tonne required to extract a mineral, resulting in lower carbon emissions. It is estimated that "2% of the total world's power is consumed by comminution" Han (2003) so small efficiency improvements could reap significant global reductions.
- Extending the operational life of consumables will reduce the replacement demand on manufactured parts. According to Han (2003) it is estimated that a further 10% of energy (over and above production requirements) is used to manufacture consumable parts (grinding media and wear linings.) In addition large quantities of steel are used in the manufacture of these items (500,000 tons annually in the USA) which adds a further environmental multiplier to the use of grinding equipment.
- Improving system stability in the mill has positive implications for optimisation and mineral recovery rates for the macro system. By producing ground ore at a consistent rate and size, the downstream process adjustments can be analysed more effectively and adjusted in improve the system and reduce energy consumption.

- Many mines are in remote locations, and as such produce their own power through fossil fuel generation systems. Fuel to produce the power is either trucked, shipped or piped to site, which in itself consumes additional energy resources. Improved extraction efficiency will reduce these requirements and further reduce the carbon output of the mine.

3.17 Occupational Health and Safety considerations

Occupational Health and Safety is a paramount consideration for all mining organisations. Work related injuries and in the extreme death, has such disastrous consequences for mining organisations that 'Safe Working Practices' is today considered one of the highest cultural priorities for mining organisations. Many governments around the world have legislated to make companies accountable for the safety of their employees as a priority over and above profit making.

As with all rotating equipment, there are significant risks to be considered when working on or near. In particular, milling equipment is massive in size and weight and represents life threatening risks to operators and maintenance staff. For this reason, new technology or procedural improvement to minimise human injury risks and well supported and adopted by mining companies. In some cases shifts to safer operational systems has resulted in improved productivity as in the case of mechanised relining equipment built by the Australian firm Russell Mining Equipment (RME). Their machinery is now used extensively for mill re-lining works due to the safe handling and five-axis aligning features to assist in removing and reinstalling lining plates. Further to the safety benefits, the use of this equipment reduces shutdown durations and saves mines money by getting their systems operational faster.

Chapter 4

Design concept solutions

4.1 Introduction

In line with the objectives of this research paper, the following section identifies four conceptual designs to reduce and where possible eliminate the operational deficiencies identified in the Literature Review. These concepts are presented at a preliminary concept level only, with theoretical system adaptation, advantages and disadvantages. These assumed designs conditions will need to be verified through further concept development.

4.2 Design concept # 1

Description: Removable Modular Shell Assembly (RMSA)

Overview: The mill shell is manufactured in flanged modular sections which when bolted together produce the cylindrical drum of the grinding mill.

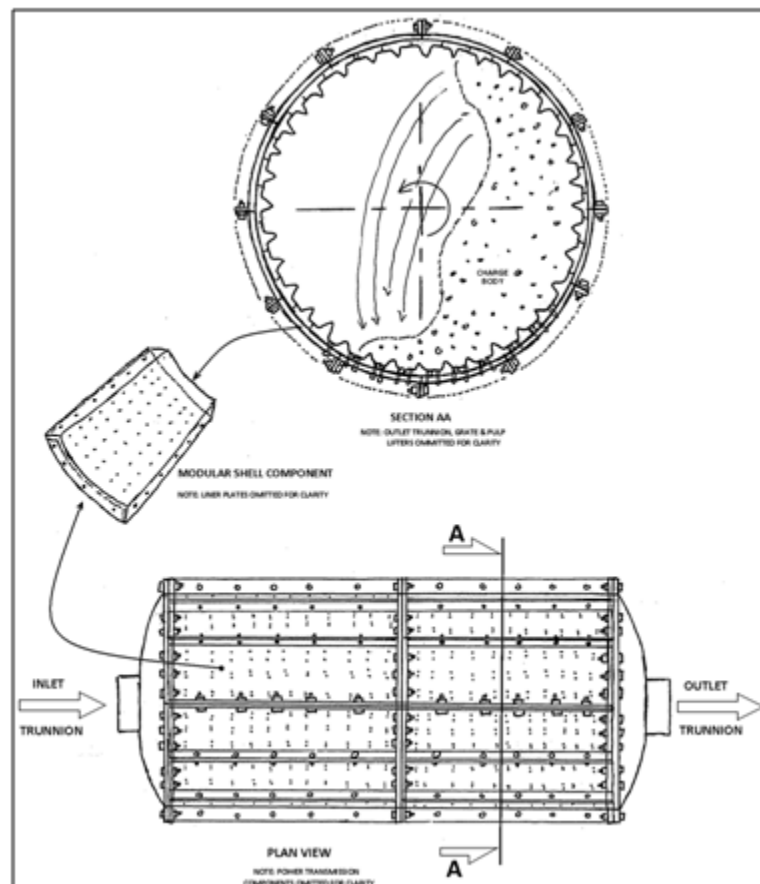

Figure 4.1: Removable Modular Shell Assembly (note: full page view presented in Appendix B)

Design advantages:

- Relining plates can be pre-bolted to modular shell sections. When shell relining is required, all removal and reinstallation works can be performed externally without requiring personnel to enter into the mill. Significant down time saving can be achieved as multiple teams can work across the three phases of the re-line; (1) loosening, (2) removal/replacement, (3) re-tensioning.
- With a modular shell system, mill contents can be quickly and easily emptied. This can be achieved by removing a modular shell section and rotating the mill until the contents empty out the opening. This might be required for the following reasons:
 - To empty charge contents for shell relining works. By emptying charge contents less power will be required turning the mill as the modular shell plates are replaced, and less packing will result from stationary slurry drying and setting into lifter buckets and less buckling stress will be produced on the weakened shell structure missing plates.
 - End liners, grates of pulp lifters require changing in which case personnel will be required to work inside the mill. By emptying the charge it will reduce working hazards and enable relining works to be performed on all 360 degree surfaces of the end walls.
 - To remove charge contents if structural works need to be performed eg ring gear or bearing replacements.
- In the event of a singular liner plate failure during operation, the modular section can be quickly and easily removed totally externally and replaced with a new pre-lined section.
- Significant OH&S benefits will be achieved by performing modular relining works away from the high pressure environment of the shut down and at a slower safer work rate. Standard overhead gantry cranes could be used to lift and locate liner plates to the modular shell and this can occur in a controlled workshop environment where no confined space works are required.
- No possibility of incorrect or insufficient lining and fixing materials for shut downs. As all of the relining works are performed well before a shut down occurs, giving logistics departments greater flexibility in ensuring correct lining materials and fixings have been supplied and if errors have occurred, time to re-order and correct the supply mistake. This will eliminate costly shut down over runs or patch up works to rectify replacement shortages, that inevitably need to be replaced during an interim shut down.
- Eliminates the need for costly specialist reline equipment. As external modular shell replacement will occur, standard overhead gantry can be used to remove and reinsert shell sections.

Design disadvantages:

- Adopting a RMSA mill system will increase the capital cost of the equipment. This is due to the additional fabrication works associated with the manufacture of the individual modular flanged sections. Considerably more welding, drill and fixings are required to produce this shell system which could result in a 20-30% capital cost increase. In addition, to effectively use the RMSA system, a second complete modular shell set will

be required on site. This will require a significantly increased capital investment by smaller operators and make it price prohibitive to organisations which are less affected by loss of production shut down costs.

- All internal confined space work is not eliminated when end lining works are required. To replace head, grate and pulp lifter liners, relining personnel will still be required to work inside the mill. This will however be assisted by the fact that shell components will be removed and end plates can be easily lowered directly into the mill from above, eliminating difficult and dangerous liner handling operations through end trunnions.
- The RMSA system is not retro-fit compatible. Existing mills would need to be completely replaced to utilise this system, resulting in a significant one off replacement cost.
- The RMSA system may have some compatibility issues with shell supported systems and traditional ring gear locations. Some design work will need to be addresses to overcome these limitations.

4.3 Design concept # 2

Description: Hinged Liner Belt (HLB)

Overview: Multiple liner plates are connected together to produce a multi-component belt.

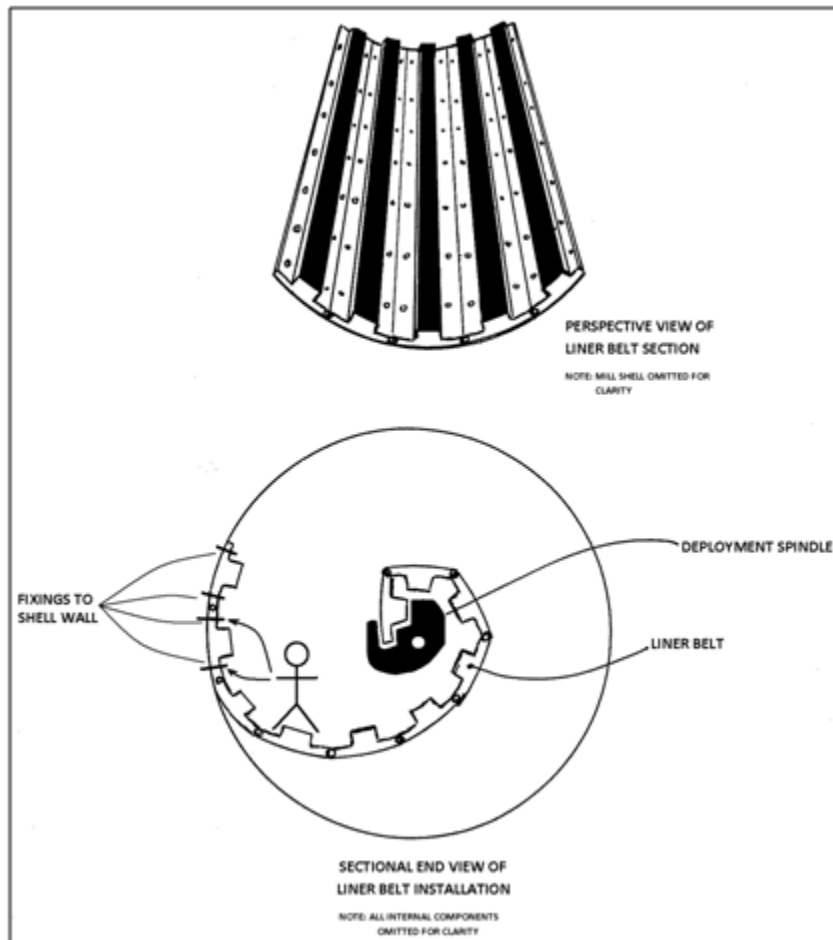

Figure 4.2: Hinged Liner Belt (note: full page view presented in Appendix B)

Design advantages:

- Multiple lining plates can be entered into the mill in one action. As the liner plates unroll from a deployment spindle significantly faster installation could be achieved.

Design disadvantages:

- Suitable for mills with large feed end openings. The HLB system once rolled around the deployment spindle will have a large diameter and consequently require larger trunnion openings to insert the belt into the mill.
- The HLB system will weigh significantly more than a single lining plate. This could pose significant OH&S and installation handling issues regarding deployment. It would be mandatory that mechanised reline equipment be used to deploy the liner belt, thus adding to the cost and logistic issues of the reline.
- The HLB system would be more expensive system to manufacture thereby increasing the cost of consumable replacement.

4.4 Design concept # 3

Description: Adjustable Deflector Plate (ADP)

Overview: An internal deflector plate is used to control cascading charge motion. Overthrown charge breaking from the shell at the top of rotation will contact the deflector plate and be directed back on grind. The plate would be supported from running bearings mounted to the feed and discharge trunnions and held in an upright position from torque produced by an external lever arm counter weight. Large compression springs would be used to dampen impact vibration and adjust the plate to direct charge onto the toe. Further system control could be achieved by including audio and impact sensors into the deflector plate to relay charge flow data to the operator.

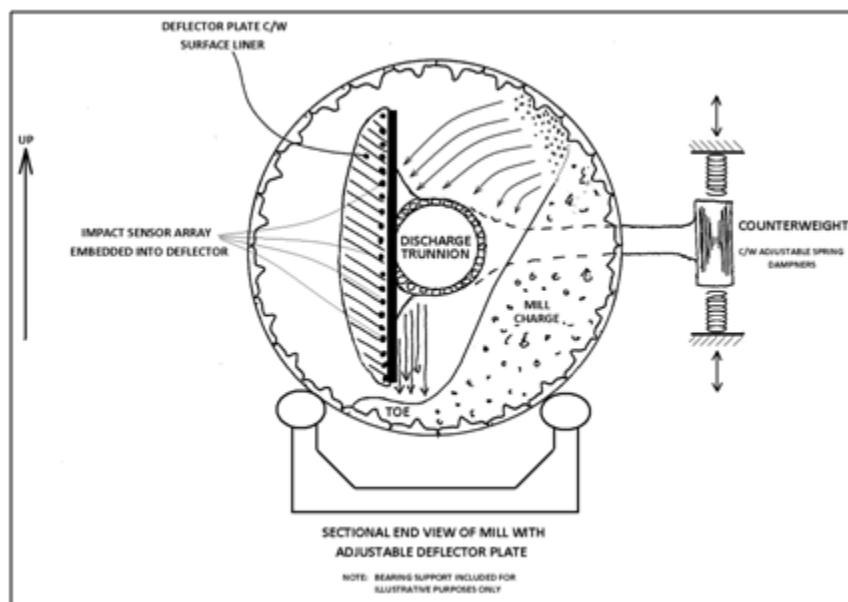

Figure 4.3: Adjustable Deflector Plate (note: full page view presented in Appendix B)

Design advantages:

- Mills can operate across a wide range of rotational speeds. Charge overthrow from higher operating speeds is eliminated giving the operator the freedom to adjust grind participation through increased rotating speeds. This would provide much greater production control particularly for highly variable ore types.
- Operators can vary the directed impact location by adjusting the plate angle. This would allow operators to trial different impact positions along the charge face to optimise impact fracture and attrition participation rates.
- Audio and or impact sensory equipment built into the plate would allow operator an unparalleled understanding of the charge motion and the implications and effects of system alterations.
- Liner and grinding media life could be significantly improved as destructive high energy ball to liner impacts would be eliminated. This would significantly extend media life by reducing ball fracture, but also eliminate impact damage and premature impact failure to lining plates.
- Wider and higher lifter/liner combinations could be trailed to increase charge lift and grinding participation, without the adverse overthrow implications typical with fewer lining plates.

Design disadvantages:

- The ADP system would only be suitable for overflow discharge mills. Pulp lifter flow restrictions due to trunnion support would make this system unviable for grate style discharge.
- Significantly increase the complexity when relining. Due to the size and obstruction of the deflector plate, relining works would be slower and have additional OH&S confined space implications.
- More maintenance components with bearing lubrication, spring maintenance, deflector surface relining, sensor replacement etc.
- Large heavy part inside mill. If support failure did occur the deflector plate would cause significant damage to the mill structure from being tumbled around inside the mill.
- Major increase in the capital cost of the component. The deflector plate, counterweight arm, springs and structural support system would come at a considerable premium to a standard ball mill. Further cost increases would occur if sensor equipment was installed.
- Installation and maintenance complexity. Due to the size of the deflector plate, it would need to be manufactured as a modular unit that could be inserted into the mill in small pieces and then assembled.
- Suitable for uni-directional rotation only.
- Due to the size, weight, trunnion supports and counter balance structure, the ADP system would not be suitable for retro-fitting to existing mills.

4.5 Design concept # 4

Description: Jet Propulsion Assisted Pulp Lifter (JPAPL)

Overview: High pressure water would be injected into the pulp lifter vanes to initiate movement of pulp and pebbles towards the discharge trunnion.

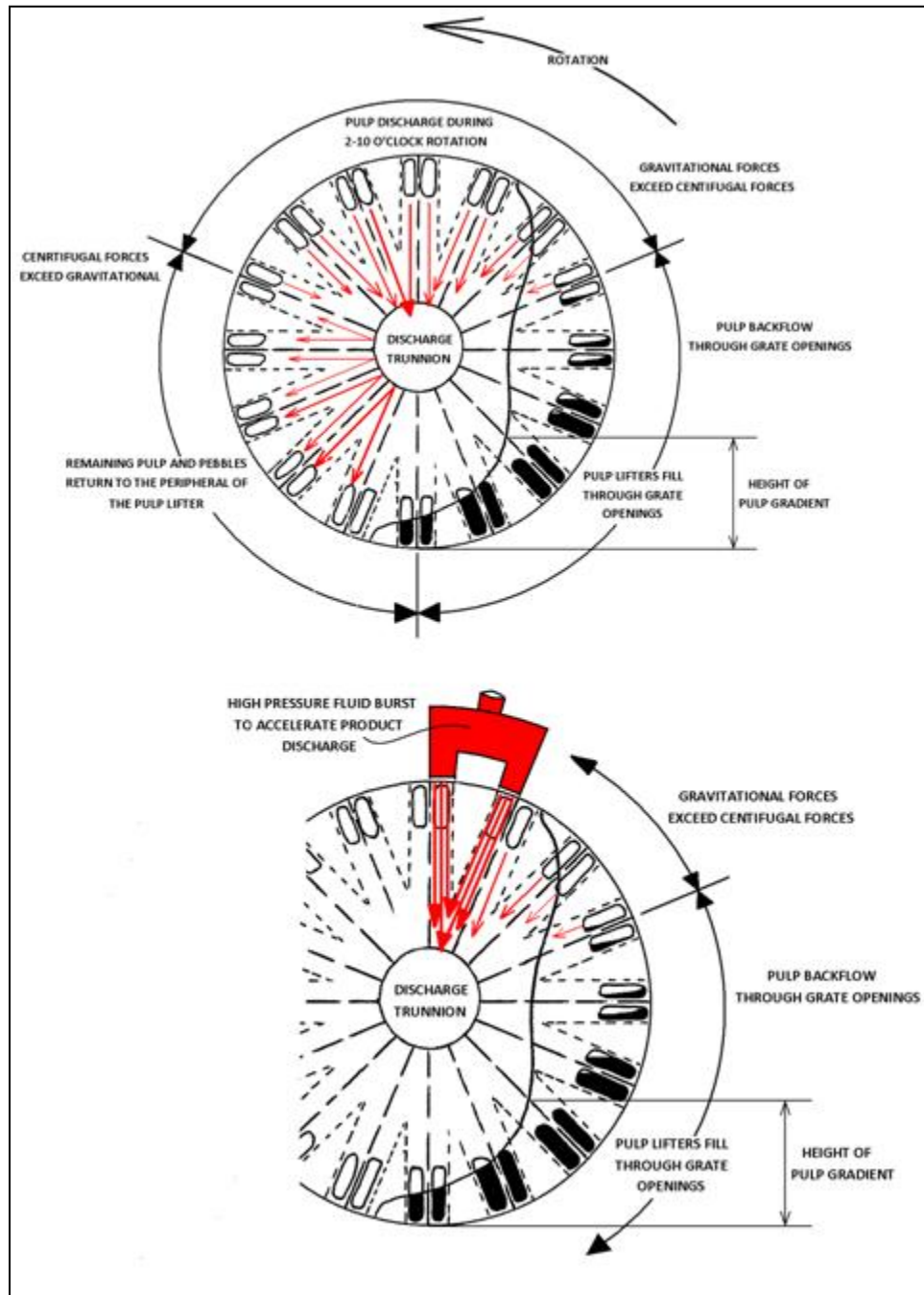

Figure 4.4: Jet Propulsion Assisted Pulp Lifter (note: full page view presented in Appendix B)

Design advantages:

- Low operating cost addition to significantly improve pulp discharge and eliminate carry over.
- Lower mounted propulsion jets could be used to drive pulp away from grate openings during Zone 2 and eliminate (or significantly reduce backflow.)
- Additional water jet propulsion would add fluid lubricant to the pulp in the lifter vanes, thereby reducing abrasive wear and extending operating life.
- By eliminating carry over, vane wear is significantly reduced and maintenance free period extended.
- Mill rotation speeds could be increased without reducing pulp discharge efficiency.
- The JPAPL system would be suitable for both straight and curved radial pulp lifters, however the greatest benefit would come from a straight radial system that offers a dual-rotation characteristic with 100% pulp discharge efficiency.
- Jet overflow through grates would increase the fluid content in the pulp and charge adjacent to the grate. This should facilitate in a higher fluid pressure gradient and greater pulp fluid flow through the grate and into the pulp lifter.
- Suitable as a retro-fit system to existing mill equipment. This would require some mill specific design work however the system should be adaptable to any mill assembly.

Design disadvantages:

- Only suitable for grate and pulp lifter discharge system.
- Logistics issues to be overcome from peripheral pulp discharge. To enter the water jet blast into the pulp lifter vane an external port would need to be drilled through the head peripheral and through the end wall of the pulp lifter. During Zone 1 of the mills rotation (the pulp lifter filling phase) centrifugal forces would act to discharge pulp through this external port opening unless it was controlled.
- Only suitable for wet grinding. Trials could be conducted using compressed air as a substitute to water, however due to the lower density of air it would have difficulty maintaining flow momentum on the pulp as it moved away from the injection port.
- Additional components and integration complexity.
- Additional capital cost.

Chapter 5

Evaluation

5.1 Introduction

Undertaking a removed, analytical and unbiased evaluation of the four conceptual designs is the focus of this section. To achieve this, a analytical evaluation tool has been developed. The tool consists of a list of performance criteria which each concept is tested against. Each test criteria was allocated a score weighting to reflect the significance of the criterion in achieving the 'Project Objectives' defined in section 1.3. The weighting was allocated based on my engineering judgement and my understanding of the industry stemming from the research undertakings and the literature review.

The following section displays a blank copy of the evaluation tool. The reader will notice it is separated into the four category groups as documented in the literature review:

- 1 Operations
- 2 Commercial
- 3 Safety
- 4 Environmental

Itemised under each of these group headings is the detailed test criteria. The tests aim to identify which of the four conceptual designs presented in section 3 offer industry value and the potential to improve current comminution operation.

To facilitate the reader's understanding of the test criterion, section 4.3 is included to develop the test specifications, purpose, applications and score weightings.

Section 4.4 provides a summary of the evaluation results and a review of each concept performance. The most commercially viable concept is then identified for further development.

5.2 Evaluation tool

DESIGN CONCEPT EVALUATION FOR:

(insert concept name here)

Description	Weight	Pass	Fail	Score
OPERATION				
Bi-Directional Capability	3			
Increase pulp transfer through grate openings	1			
Reduce pulp Backflow	3			
Improves Pulp Lifter discharge efficiency	3			
Suitable with variable mill speeds	3			
Suitable with variable charge volumes	1			
Suitable with variable ball sizes	1			
Compatible with overflow discharge systems	2			
Compatible with Grate & Pulp lifters systems	2			
Compatible with trunnion supported mills	2			
Compatible with shell support mills	2			
Compatible with wet grinding	2			
Compatible with audio sensory equipment	2			
Reduced abrasive wear	3			
Reduced impact damage	2			
Reducing charge slippage	2			
Improve charge control	3			
COMMERCIAL				
Reduce shut down duration	4			
Reduce requirement for specialist shut-down contractors/ equipment	2			
Increase production per unit operating cost	4			
Increase production per unit maintenance cost	4			
Adaptability/retro-fit to existing equipment	5			
Decrease capital cost for new equipment	1			
OH&S				
<i>Reduce Loss Time Injury (LTI) risk for:</i>				
Operation	3			
Maintenance	3			
Reducing sound emissions	1			
ENVIRONMENTAL				
Reduce consumption of operational consumables per Tonne output	2			
Improve energy efficiency of the grinding system	3			

TOTAL

0

Table 5.1: Concept evaluation tool

5.3 Criterion description and weighting

5.3.1 Introduction

Explanation of the evaluation criteria and justification of the allocated weighting is provided below. Designs meeting these criteria are awarded the applicable weighting score during the critical evaluation.

5.3.2 Production

The following items contained within subsection 4.4.2 are operational specific evaluation criteria.

5.3.2.1 Bi-Directional Capability: The proposed concept should be compatible with a dual-direction rotation system. This means the concept will function to its full design specifications whether the mill is rotating in a clockwise or anti-clockwise direction. The benefits of dual rotation on extended operating life and reduced maintenance cost is a significant operational advantage. As bi-directional rotation is a standalone operating parameter with significant financial and maintenance benefits it was weighted a score of 3.

5.3.2.2 Increase pulp transfer through grate openings: The proposed concept should improve the efficiency of the discharge system by facilitating with increase pulp passage through the grate and into the pulp lifters. Although the benefits of improved discharge efficiency are an important system development, this would only be realized if the system could provide the additional pulp through increased grinding efficiency. As a coupled evaluation criterion increasing pulp transfer was weighted a score of 1.

5.3.2.3 Reduce pulp Backflow: The proposed concept should reduce and if possible eliminate the negative effects of pulp backflow through the grate. Reductions in backflow will significantly improve the mills operating efficiency, resulting in lower energy consumption and reduce grate and pulp lifter wear. For this reason reducing pulp backflow was weighted a score of 3.

5.3.2.4 Improves Pulp Lifter discharge efficiency: The proposed concept should improve the discharge efficiency of the pulp lifter and reduce pulp carry-over. By improving pulp discharge the full capacity of the lifter vane can be utilized each rotation with no loss of capacity due to pulp carried over from the previous rotation. In addition, operating life of the pulp lifter would be dramatically improved as wear from carry-over would be eliminated. The operating and maintenance saving from discharge improvement is significant and consequently allocated a score weighting of 3.

5.3.2.5 Suitable with variable mill speeds: The proposed concept should operate effectively across a range of operating mill speeds. Changing mill rotation speed is a vital system

adjustment to stabilise production and counter changes in ore hardness. For sensitive flow circuits (flotation, magnetic separation etc) significant production savings can be achieved by a well balanced and stable system. For this reason adjustable mill speed is weighted a score of 3

5.3.2.6 Suitable with variable charge volumes: The proposed concept should continue to effectively function across a range of charge volumes. Volumes will fluctuate for a range of reasons; due to process instability, if higher production rates are required or if harder ore requires an increase in grinding media charge percentage. Changes to volume are generally slight and typically have little effect to other operation parameters, so for this reason variable charge volumes are only weighted a score of 1.

5.3.2.7 Suitable with variable ball sizes: The concept design should be capable of functioning across a range of grinding media sizes. Changes in grinding media occur to increase fracture and attrition rates and improve grinding participation in the field of breakage. Generally though, ball sizes vary slightly and typically do not occur frequently as different ball sizes need to be present on site to make the change. For this reason variable ball sizes are only weighted a score of 1.

5.3.2.8 Compatible with overflow discharge systems: The design concept should work efficiently with an overflow discharge system. Although most AG and SAG equipment used grates, many ball and rod mills still utilize the simpler and cheaper overflow discharge method. This criterion is weighted a score of 2.

5.3.2.9 Compatible with Grate & Pulp lifters systems: The design concept should work efficiently with a grate and pulp lifter discharge system. With an industry shift towards SAG milling equipment (which extensively uses grate discharge) it is important the design be compatible with this style of mill discharge. This criterion is weighted a score of 2.

5.3.2.10 Compatible with trunnion supported mills: Many older and smaller grinding mills use the traditional feed end trunnion support system. The concept design must be compatible for use with this method of support. This criterion is weighted a score of 2.

5.3.2.11 Compatible with shell support mills: Due to the large diameter AG and SAG mills being manufactured and the structural fatigue issues surrounding trunnion support, many new mills are moving towards a shell supported design. The concept should be compatible with this support method. This criterion is weighted a score of 2.

5.3.2.12 Compatible with wet grinding: The design concept should be compatible with a wet grinding process. Most mineral extraction processes use wet grinding. The addition of water aids in dust suppression, greater fluid pulp transfer, noise suppression and wear reduction. Wet grinding has broad application within the mineral recovery industry and for that reason is weighted a score of 2.

5.3.2.13 Compatible with audio sensory equipment: Although new technology, audio sensory equipment has proven effective in predicting charge motion. The concept should be compatible for use with sensory equipment. This criterion is weighted a score of 2.

5.3.2.14 Reduced abrasive wear: Abrasive wear is an enormous contributor to the operating and maintenance cost of grinding equipment. A reduction to the rate or effect of abrasive wear from the concept design would add significant financial benefit back to the mine. This would be realized from; lower consumable costs (grinding media), less liner replacement and fewer shut-downs. For this reason, reduced abrasive wear is weighted a score of 3.

5.3.2.15 Reduced impact damage: Impact damage occurs predominately from direct shell liner impacts from thrown charge. Particularly in large diameter AG and SAG mills (up to 12m diameter) high impact forces are produced by high velocity grinding balls and larger ore particles directly striking the liner. The design concept should reduce the occurrence of these direct impacts. Reducing impact damage will benefit the mine in several ways. First premature liner failure would be eliminated. Secondly, greater grinding (and ultimately efficiency) would result from bring this overthrown charge back on grind. For these reasons, concepts reducing impact damage are weighted a score of 2.

5.3.2.16 Reducing charge slippage: Charge slippage occurs during the upward rotation of the mill, when charge being held by the liner lifters slip down to the lifter below. This occurs when the bucket depth is lost due to packing or lifter spacing and angles are too great to hold the charge nearing the break point of rotation. The design concept should minimise or eliminate the occurrence of slippage during rotation. Benefits from this reduction would occur through lower lifter wear and maintenance costs, greater charge lift and ultimate grind participation, and finally better control over thrown charge at the angle of break. For these process benefits, reduced charge slippage is weighted a score of 2.

5.3.2.17 Improved charge control: Charge control is an important operational characteristic of efficient and economical mill operation. Not only for the reason above (reduce abrasion and impact damage), but because greater charge control results in greater grinding participation and efficiency in the field of breakage. It is widely accepted in the comminution industry that a higher rate of tumbling impacts down the face of the charge yields greater grinding returns than a single high impact collision from thrown charge landing at or near the toe. Design concepts that can provide operators with greater control over the charge motion and impact locations would provide significant operational advantages. For this reason, improving charge control is weighted a score of 3.

5.3.3 Commercial

The following items contained within subsection 4.4.3 are commercial specific evaluation criteria.

5.3.3.1 Reduce shut down duration: Due to the high capital cost of milling equipment, most mine sites have only one mill or if multiple mills are installed they are designed to run in series

not parallel. This means that for most extraction circuits that when the mill is not operational, further downstream processing circuits have no ore feed and are consequently idle. The result, when the mill is shut down the mine is not making money. In fact the opposite is true, during a shut down, many of the costs continue to accumulate, including staff wages, power generation (all be it at a decrease level), interest on finance, port and rail contracts etc. Loss of production can be a significant due to a mill and plant shutdown. For this reason, the design concept should reduce shut down duration by providing some innovate way to accomplish maintenance and repairs quicker whilst maintaining a safe working environment. For the significant financial cost associated with shut downs, this criterion is weighted a score of 4.

5.3.3.2 Reduce requirement for specialist shut-down contractors and equipment: Mill relining and other associated mill maintenance works is generally outside of the scope and labour availability of most mining organizations. For this reason, specialist relining contractors are typically engaged to provide the labour and expertise to remove and replace internal lining components. Specialist contractors are generally expensive and contribute significantly towards the total cost of a reline. Further to this, many of these contractors freight to site specialist lifting and handling equipment at considerable freight and hire costs to the mine. The design concept should reduce the dependence on this specialist labour and equipment. By doing so, mines would have greater maintenance flexibility, greater price competition and fewer logistical issues around labour and equipment performance during the shutdown. For this reason, reducing specialization has a weighting score of 2.

5.3.3.3 Increase production tonnage per unit operating cost: Operating grinding mills requires a lot of power. Not only to turn the mill, but also to power the adjoining conveyor systems required to feed and remove ore from the circuit. Improvements in the operating efficiency of the grinding circuit will reduce the operating cost per tonne of ore throughput. The design concept should positively contribute to an improved system efficiency and ultimately to a reduced operating cost of the comminution circuit. For the significant financial benefits of improved system efficiency, improved production per operating cost are weighted a score of 4.

5.3.3.4 Increase production tonnage per unit maintenance cost: Maintenance, be it the cost of replacement parts, the labour to perform it or the loss of production during a shut down, is a major cost of grinding. The design concept should make a genuine contribution to reducing this maintenance cost by extending component operating lives and reducing the cost of shutdown repairs. For these reasons reducing maintenance costs is weighted a score of 4.

5.3.3.5 Adaptability to existing equipment: Mills have enormous up front capital costs. For a design concept to be truly beneficial to the wider comminution industry, it would need to be adaptable to mills currently in operation on mine sites around the world. For this reason adaptability is weighted the top score of 5.

5.3.3.6 Decrease capital cost for new equipment: Decreasing the capital cost of milling equipment will reduce setup costs and make more mines viable. The design concept should aim to reduce the up-front capital cost of the grinding mill. This criterion is weighted a score of 1.

5.3.4 Occupational Health and Safety

The following items contained within subsection 5.3.4 are Safety specific evaluation criteria.

5.3.4.1 Decrease Loss Time Injury (LTI) risk for Mill Operation: Day to day operations accounts for the vast percentage of a mill's life. Due to the importance of the equipment it is rarely turned off and if it is there is constant pressure to get the equipment operational again. For this reason the design concept should improve to the operational safety of the mill for miner personnel. This criterion is weighted a score of 3.

5.3.4.2 Decrease Loss Time Injury (LTI) risk for Mill Maintenance: there are probably fewer high pressure maintenance jobs on a mine site than mill relining and maintenance works. Management apply significant pressure to maintenance crews to safely, but expediently complete maintenance programs. The design concept should improve the safety profile of maintenance work while reducing the duration of the shut down. This criterion is weighted a score of 3.

5.3.4.3 Reducing sound emissions: noise pollution is a constant issue around mining equipment. The grinding mill along with other comminution processes produce more noise than all of the other extraction processes combined. The design concept should look at ways to reduce the operating noise level of the equipment and reduce its noise pollution output. This criterion is weighted a score of 1.

5.3.5 Environmental

The following items contained within subsection 4.4.5 are Environmental specific evaluation criteria.

5.3.5.1 Reduce consumption of operational consumables per tonne output: By reducing consumable consumption a range of carbon footprint reductions occur. Firstly less steel is required (and ultimately less mining) to produce the consumable parts, less energy is required to mould and manufacture the parts and finally, less energy is required to transport the items to site. All this multiplied across thousands of mines worldwide presents major carbon output reductions through system efficiency. The design concept should add in some way to achieving some system efficiency and reducing the industries environmental impact. For this reason reduced consumption is weighted a score of 2.

5.3.5.2 Improve energy efficiency of the grinding system: By improving the energy efficiency of the mill, the net production result is a higher throughput production per kJ energy consumed. As many of these grinding mills consume in excess of 20kWt/h per tonne of ore throughput, even small energy reductions will result in noticeable carbon reductions. The design concept should contribute by reducing the carbon footprint of the mine through improving the operational efficiency of the equipment. This criterion is weighted a score of 3.

5.4 Critical evaluation

Table 5.2 summarises the category and overall performance result of each concept. The scores presented are drawn from each concept's 'Evaluation Form' as detailed in the Appendix section C1 through C4. A grey highlight was used to identify the top performing concept in each group category and finally a yellow highlight to identify the top overall performing concept.

EVALUATION TOOL SUMMARY					
Concept	Operation	Commercial	Safety	Environmental	Total
Concept #1: Removable Modular Shell Assembly (RMSA)	20	14	3	0	37
Concept #2: hinged Liner Belt (HLB)	20	13	0	0	33
Concept #3: Adjustable Deflector Plate (ADP)	20	4	1	5	30
Concept #4: Jet Propulsion Assisted Pulp Lifter (JPAPL)	28	13	0	3	44

Table 5.2: Evaluation tool results summary

5.4.1 Result summary

5.4.1.1 Operation: Concept #4 demonstrated significant dominance in this critical performance testing area scoring 28 points out of a possible 37 (76%). The JPAPL score exceeded the other tested concepts by 40%, and as such this concept demonstrated superiority for the operational performance category.

5.4.1.2 Commercial: Concept #1 was the top performer tested against the commercial evaluation criterion scoring 14 out of a possible 20 (70%). It should be noted however this was only marginally superior to both concepts 2 (HLB) and 4 (JPAPL), with both scoring closely behind with a 65% evaluation compliance.

5.4.1.3 Safety: Again concept #1 rated as the top performing concept relating to Safe Working standards. The RMSA concept scored clearly ahead of all other tested concepts achieving 43% compliance.

5.4.1.4 Environmental: Concept #3 demonstrated the greatest potential environmental benefits scoring a maximum 100% compliance.

5.4.1.5 Overall Performance: Concept #4 was the top performing concept based on the total cumulative results of the evaluation criteria. The JPAPL concepts achieved a total aggregate score of 44 from a possible 69 with 64% test compliance.

5.4.2 Concept review

5.4.2.1 Concept #1: Although not achieving the highest total performance score, did rate highest in two of the four testing areas. In addition it performed well relating to the operational compliance and rated comfortably as the second highest performing concept with an overall test score of 54%.

5.4.2.2 Concept #2: Demonstrated potential in both operational and commercial test areas, however performed poorly against both Safety and Environmental. With an overall test score below 50% this concept did not present well for further development.

5.4.2.3 Concept #3: Presented well relating to operation and environmental considerations, however scored poorly against the commercial and safety areas. With its overall score also below 50% this concept would not be further developed.

5.4.2.4 Concept #4: Scored highest on operational compatibility and performed well in two of the remaining three other categories (commercial and environmental). In addition it also achieved the highest overall concept score with 64%.

5.4.3 Concept selection

Concept #4 the 'Jet Propulsion Assisted Pulp Lifter' (JPAPL) due to its superior testing performance was selected for further concept development. In addition, and due to its strong sectional performance Concept #1 'Removable Modular Shell Assembly' (RMSA) was also identified as exhibiting strong commercial viability and as such would also be developed further conceptually.

Chapter 6

Removable modular shell assembly (RMSA)

6.1 Introduction

Mill relining is a costly but necessary maintenance process for all mineral extractors. Relining becomes necessary once the internal lining plates excessively wear or are damaged due to the aggressive internal grinding and tumbling action of the charge contents. Wear rates and relining frequencies vary from mill to mill, however due to the importance of grinding equipment and the significant cost associated with relining, when it is required it is always a well planned and tightly monitored event.

Due to the high pressure environment of a mill reline shutdown, everyone involved in the event are under significant pressure. Maintenance planners are accountable for purchasing new lining and fixing components as well as booking relining specialists to be available for the job at the specified date. Shutdown supervisors are tasked with completing the relining works in the shortest possible time and to a standard required to ensure the equipment will remain maintenance free for the next designated operation cycle. Relining crews are closely scrutinised by the shutdown supervisor and site safety officers checking that they both meet the allocated maintenance targets whilst working in a safe and professional manner. And finally the safety offices must actively engage with all parties to ensure correct work procedures are followed even at the expense of completion targets.

Identifying ways in which all of these objectives can be met is the focus of this mill relining concept. The RMSA aims to reduce potential ordering errors for planners as the modular shell relining would occur before a shutdown is scheduled and takes place. Due to the modular system, planners would be less reliant on specialist contractors as the complexity of the relining process is significantly simplified. Shutdown supervisors have a system where the offline duration can be significantly reduced, while safety officers have fewer concerns as much of the heavy and dangerous relining works have occurred prior to the shutdown thus minimising the risk of human injury.

In this section further investigation will be undertaken examining the RMSA system. First an equipment review will be provided and an in-depth identification of the modular shell system components. A stepwise shutdown process recommendation will be developed identifying various ways which the RMSA system could be utilised. Finally, I will explore problematic areas of the concept around equipment integration and implementation difficulties.

6.2 Relining overview

Prior to commencing development of the RMSA concept, a brief overview of a typical relining process will be discussed. Currently relining is undertaken on a simultaneous internal and

external work basis. Old and damaged lining plates (often weighing several tonnes each), are supported internally whilst fixings are removed from the outside of the mill shell. Once the bolts are removed, the plates are shocked loose from their shell position, and removed from the mill through the trunnion opening. Traditional lining systems use some version of a hoist system to raise/lower and locate the internal lining plates and a conveyor roller system to insert or remove the plates through one of the end trunnions. These methods are time consuming and involve a lot of human interaction with the lining plates (with the associated pinch and crushing related injuries typical of this heavy confide work.) Furthermore, this relining process is slow as the hoist and conveyor assembly continually requires relocating as the mill is rotated to make new lining surfaces accessible.

More recent equipment developments have seen a partial shift towards mechanised relining machinery like those illustrated in figure 6.1. Manufactured by Russel Mineral Equipment, this machinery has reduced the laborious rolling conveyor to inert and remove lining plates as the installation handler now traverses the internal and external spaces using a hydraulic telescopic boom. The equipment also eliminates the need for internal hoists as the hydraulic system (now available in an 8-axis model) can safely lift, insert and position the liner plates directly into position. These significant advances to productivity and safety do come at a substantial equipment price and still requires specialist reliners to operate the equipment. Further, the relining machinery requires a substantial working platform to setup which must be capable of supporting the large weights of the equipment and lining plates. One final operational limitation is the access required through the trunnion to fit the equipment and lining plates through.

Regardless of whether a mine opts to use newer mechanised liner handling equipment or retain traditional internal hoist and conveyor methods, both require lining personnel to enter and work inside the mill. This confined space lining is widely acknowledged as one of the more dangerous maintenance tasks required on a mine site.



Figure 6.1: RME liner handling machine and operator (Source: <http://www.rmeaus.com/>)

6.3 Removable modular shell assembly

The RMSA system is an adaptation from the current grinding industry. RMSA would utilise existing mill equipment, while applying construction and assembly slightly differently. As identified during section 3.14 of the Literature Review, all mills consist of three fundamental components:

- The Feed Head
- The Shell
- The Discharge Head

Currently, once a mill is installed, these three components remain permanently fixed together, thus requiring all future internal works to be undertaken through the Feed/Discharge Head Trunnions. The RMSA system proposes to modify this convention. By introducing a Modular Shell assembly; sections of the shell can be detached by removing bolt fixings along the flanged perimeter of the shell plates as illustrated in figure 6.2 below. This modular component design means shell relining works (or other internal lining) could be undertaken completely external (or with the aid of external access) of the mill.

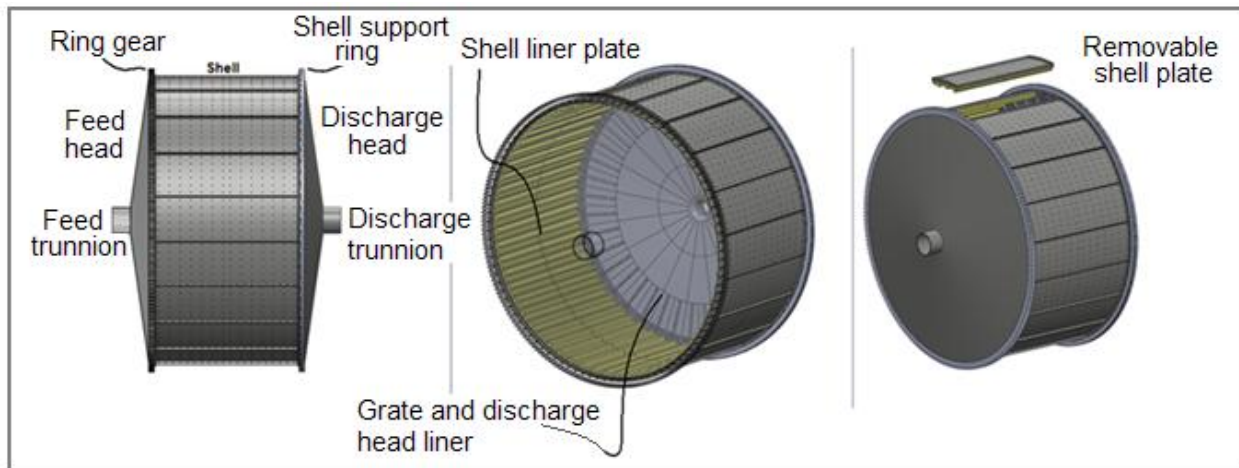

Figure 6.2: RMSA mill component identification

Further engineering is required to determine the practical size of the shell components. This research would look at optimising the shell plate to diameter ratio. By reducing the number of shell components; manufacture, assembly and maintenance costs could be minimised. These cost savings would be realised by:

- Reducing manufacturing time and materials: By reducing shell components, the number of shell jointing flanges would be reduced culminating in a reduction of steel flange material, milling to prepare and drill plates, welding consumables and equipment/labour resources and finally bolt fixings to join flanges.

- Reducing installation: Reducing shell plate numbers ultimately yields shorter installation duration as fewer shell flanged joints would require fitting and tensioning.
- Reducing maintenance and shutdown durations: Fewer shell plates will result in shorter relining shutdowns. As relining would occur with larger shell plates, less time would be required to loosen, remove, replace and re-tension flange bolts. These reductions in shutdown durations yield one of the greatest benefits of RMSA system.

Some important design considerations when further developing the RMSA system would include:

- Maintaining structural integrity: As shell components are removed from the mill, the buckling strength of the mill is significantly reduced. Detailed Finite Element Analysis (FEA) and structural analysis will be essential to optimise shell component numbers, while ensuring the mill asset is protected from structural failure. The modular shell system could itself present a partial solution to this structural problem. By removing one of the shell plates and inching the mill around (until the missing section is facing down), the mill's charge could be emptied. By removing the charge from the mill a significant reduction in bending stress would be realised. This could be achieved by utilising a double shell configuration as detailed in figure 6.3 or by designing a reinforcing frame and discharge chute which could be bolted to the mill shell prior to contents discharge.
- Weight of the shell and liner assembly: Reducing the number of shell plates results in an increase of the overall size of the shell. When considering the shell would be constructed from 25mm plus thick steel plate and with the additional weight of shell liners bolted to the internal surface, these removal components could weigh upward of 10-30 tonne. Lifting capacity of the site would need to be considered while optimising the shell configuration. A sites lifting capacity would set a ceiling for the maximum combined mass of the modular shell and ultimately the minimum number of shell parts.
- Handling and installation: A further development of larger and heavier plate sections (outside of weight alone), would be the handling and fitting capacity of the shell sections. As the mass of the shell assembly increase so too does the difficulty to remove, locate and align shell section to the mill. This consideration is of particular importance when considering that lifting would be provided from cranes, which will only provide vertical support. All rotation, alignment and fitting will need to be provided by additional hydraulic or manual handling equipment.

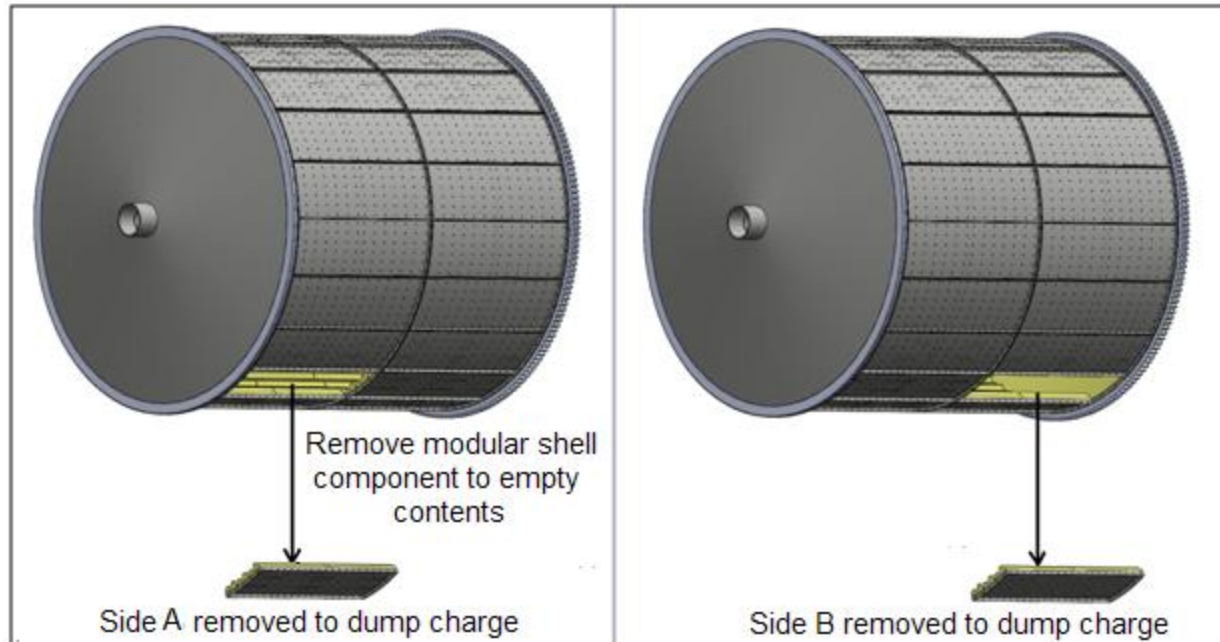

Figure 6.3: Emptying contents

6.4 RMSA methodology

The RMSA system consists of a series of flanged shell components. The liner and lifter plates are bolted to the internal surface of the shell components. Once these shell/liner assemblies are bolted together in a circular array they form the body of the mill. This section is included to develop the use and application of the RMSA system and how it could add value to comminution industry.

6.4.1 After the shutdown

For simplicity, it is easier to start describing the RMSA life cycle assuming a shut down has just been completed. The newly relined mill is operational after a successful shutdown. Stacked adjacent to the mill, are the recently removed shell assembly components. Depending on the weight of the shell assemblies and the availability of equipment on site, the plates would be moved using a large forklift, mobile crane or loaded onto a flat bed trailer and sent to storage away from the plant's operations area.

The removal of old liners and replacement with new parts can now be undertaken. This would typically be actioned directly following the shutdown to ensure new replacement parts are ready for the mill as required. The advantage of the RMSA system however is that the mine now has two options for relining:

- Perform the maintenance works onsite using staff or contracted labour
- or
- Sub-contract the relining works out to an external (off-site) contractor.

For remote mines the relining would likely be conducted on site due to the prohibitive cost of freight. For mines closer to a regional centres supported by external industry, there could be greater financial benefit by outsourcing the maintenance work.

Regardless of who or where the relining works are performed, the relining methodology would be similar. First the old worn liner plates need to be removed from the shell. How this would be approached would depend on the fixing methodology. For a traditional bolt and nut connection, the shell plate would need to be mounted onto an A-frame as illustrated in figure 6.5. Then, both sides of the liner can be accessed and the bolts removed. Suitable liner handling equipment would need to be used to safely lift and remove the worn liners. Alternatively, more recent trends have seen a shift away from a hole penetration through the liner and to a drilled and tapped thread fixing point into the back of the liner. Assuming this application, liners could remain on the ground and fixings removed from the outside see figure 6.4 below.

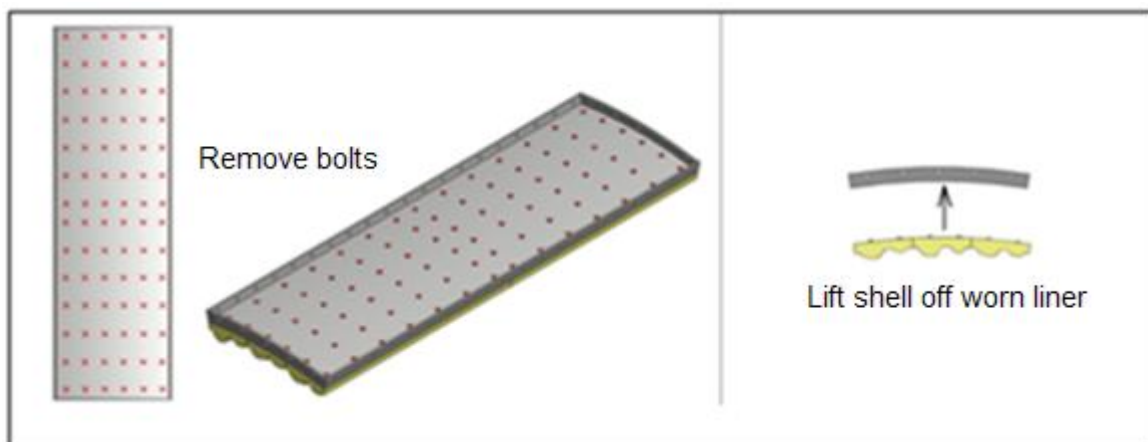

Figure 6.4: Liner removal from modular shell plate

With the worn liners removed, shell maintenance can be addressed. This could be in the form of corrosion control, maintenance to shell contour (remove dents) or repair to flanges. Once ready to reline, the shell components would be mounted onto the A-frame. Lining plates could then be lifted and bolted to the shell using a suitable liner handling device. Lifting and handling could be as simple as using overhead cranes and counter balanced lifting frame (refer to figure 6.5) or for improved relining accuracy continue to utilise specialist relining equipment like the multi-axis relining machines built by RME.

On completion of the relining, the shell components would be sent to storage ready for the next relining shutdown.

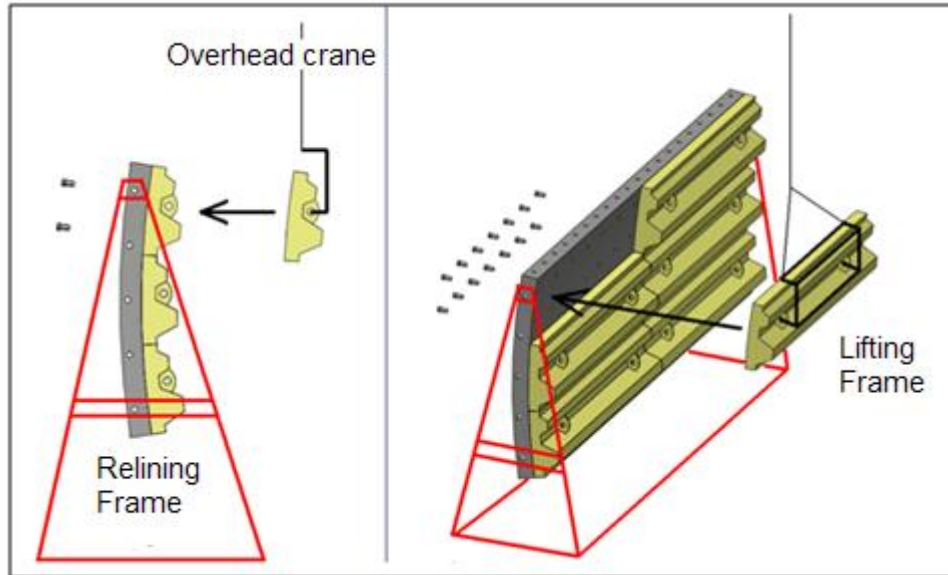

Figure 6.5: Shell relining simulation

6.4.2 The next shutdown

The size and type of mill will dictate how a reline would be approached. For mills without satisfactory access platforms, temporary work platforms would need to be constructed ready for installation immediately after the mill is shutdown. These platforms could simply be heavy weight scaffolding or a more permanent drop-in structure. To maximise relining productivity, the access should be constructed with two levels as illustrated in figure 6.6. Assuming a *clockwise* relining direction, level 1 would be used to loosen flange perimeter bolts and remove the old worn lining shells. New shell components would then be refitted with only some of new fixings replaced and tensions (possibly every fourth or fifth fixing would be reinserted and tensioned at level 1.) When the mill is inched further around, level 1 repeats this process, while level 2 replaces the remaining flange bolts and tensioned out all of the fixings. This multi level production could significantly reduce the total shutdown period required for mill relining.

For structural integrity reasons, shell removal and replacement should only be performed on the outermost vertical shell. This is because at this point the upper and lower adjoining shells are both still relatively vertical and consequently provide greater bending resistance due to its moment of inertia. Strict adherence to this lining protocol must be enforced as removal of lower or higher shells will weaken the mill's bending strength and risk buckling.

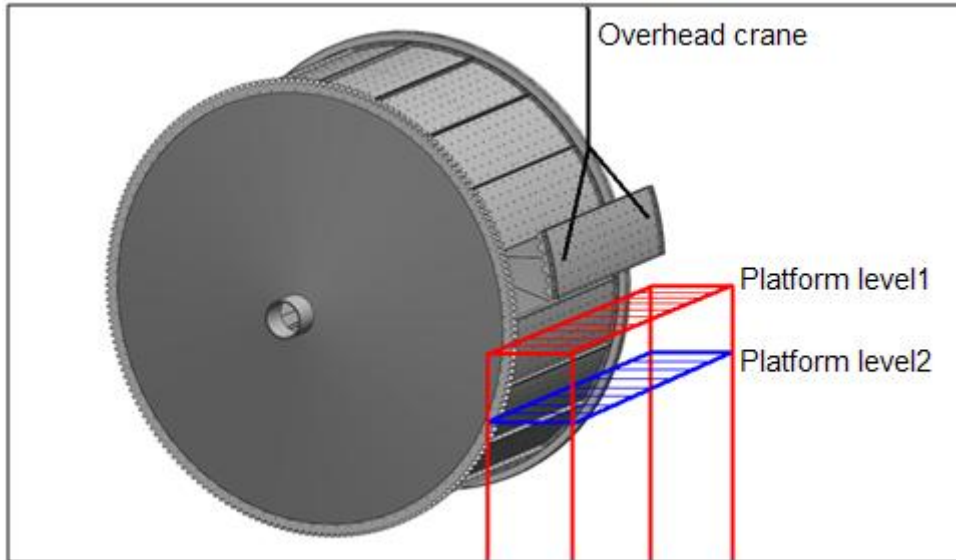

Figure 6.6: Shutdown simulation

Removal and realignment of the modular shell plates will be one of the greatest difficulties of this RMSA system. Due to the large weight of each modular section and the tight mating tolerances, specialist fitting equipment will likely be required to facilitate speedy removal and reinstallation. To assist with removal and realignment, the modular shell flanges would be manufactured utilising natural and built in tapers highlighted in figure 6.7 below. Peripheral shell to shell tapers naturally provide clearance relief until the point of correct alignment, while shell to head flange connections require a machined or fabricated taper to provide clearance for alignment. This head flange taper will result in higher manufacturing cost, however the benefits gained from an easy fitting shell assembly would quickly realise the upfront capital increase.

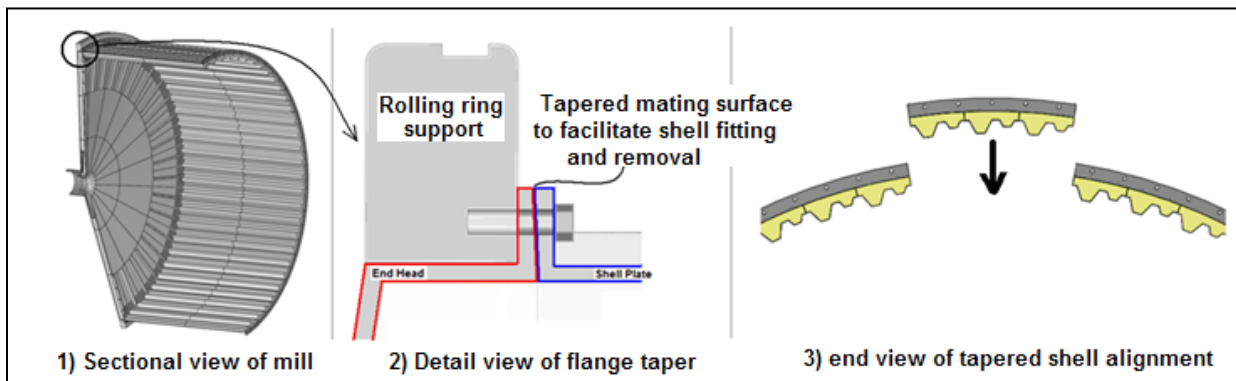

Figure 6.7: Tapered flange connections

6.5 Integration limitations

Due to the conceptual nature of this design research, some concept limitations need to be acknowledged. Although not ruinous, thorough consideration would need to be given to integrating essential milling components with the effective use of this concept design. These limitations are detailed as follow:

6.5.1 Power Transmission and Shell Support: Common to all mills is the inclusion of a large peripheral ring gear at the feed end of the mill, and more frequently a shell support guide at the discharge end. For effective application of the RMSA concept, these power transmission components would need to be located as far as possible towards the feed and discharge heads. The optimum location would be positioning the gear and guide to the outside of both head flanges (see example of the rolling guide location in figure 6.7

6.5.2 Head Liners, Grates and Pulp Lifters: Although conceptually, the RMSA system presents value in reducing shutdown durations and improving relining worker safety, the system is not capable of providing the same advantages for relining of feed or discharge head components. For these works, reline crews will still be required to enter and work inside the mill. That said however, some advantages could be gained from the external access of removed shell components for the removal and introduction of end liner plates. Even without realising this advantage, multiple relining fronts can be established simultaneously with internal head linings running concurrently with external shell works, thus reducing the shutdown duration.

6.5.3 Shell Handling and Alignment: as identified earlier, one of the greatest difficulties of this system would be achieving sufficient shell alignment control. Using overhead cranes reduces a mines dependence on specialist lining equipment (like that of RME), however cranes do have some clear limitations:

- Gantry style cranes may struggle with lifting capacity
- Slewing cranes could have access restrictions (inside buildings, adjacent structure), reach and weight limitations
- Both cranes types provide only vertical lift and have no ability to apply horizontal or rotational forces to locate and align shell plates.

Although contrary to one of the earlier identified conceptual advantages, the RMSA system would possibly require the use of some kind of hydraulic mechanised liner handling equipment to assist with shell placement and alignment. This equipment could be simplified from existing relining machinery, however it would provide clear advantages by applying a broader range of loading capabilities for removing and replacing shell plates.

Chapter 7

Jet Propulsion Assisted Pulp Lifter (JPAPL)

7.1 Introduction

Efficient Comminution using horizontal rotating grinding mills requires two principal actions. Firstly, the reduction of particle size from impact and attrition within the charge. And secondly (being the focus of this concept) the removal of ground material from the mill.

Efficient pulp removal is crucial to a stable and effective grinding system. Not only to maintain the volume equilibrium, but also to remove smaller energy absorbing particles from the field of break. As particles reduce in size greater loads are required to further reduce them. This is because smaller particles have a higher 'Bond' co-efficient and if this pulp material is not removed a greater percentage of mill energy is wastefully transferred to this ready to discharge pulp matter. By efficiently discharging pulp as soon as it is reduced to an appropriate mesh, energy within the system is continuously being directed to reducing oversize ore.

This section aims to focus on improving this discharge process and consequently improving the efficiency of the grinding mill. First a general review will be provided on the discharge process. The Jet Propulsion Assisted Pulp Lifter concept will then be explored with several concept designs proposed and developed. Finally, identification of concept limitations and integration issues will be presented.

7.2 Discharge review

Discharge occurs in one of two ways. As an overflow method whereby charge spills out over the mill's discharge trunnion, or via a more controlled grate and pulp lift configuration. The overflow method of discharge is difficult to regulate and always requires some level of post-grind screening, with oversize ore and charge balls being returned back into the grinding circuit. The grate and pulp lifter method, offers built in grade screening as ore cannot pass to discharge until small enough to fit through grate openings. This eliminates the energy and cost associated with the post-grind screening and oversize return.

During a pulp lifter discharge, pulp and small pulp pebbles pass from the mill through the grate openings and are held in radial vane channels that extend from the shell peripheral to the centre discharge trunnion. These vanes are fixed to the discharge head and rotate with the mill. Assuming a counter clockwise rotation, the vanes fill as they rotate from 6 o'clock to 9 o'clock. As the mill continues to rotate past 9 o'clock, the vane angle changes such that gravitational forces acting on the pulp slurry content exceeds the rotating centrifugal holding forces and the pulp begins to flow towards the axis of rotation and the discharge trunnion. Gravitational discharge forces are greatest between 11 o'clock and 2 o'clock where the majority of the pulp lifter contents are discharged. Larger pulp pebbles (due to their greater mass) hold at the lifter

peripheral for longer than the pulp. As a consequence, by the time the mill rotates through 2 o'clock (and centrifugal forces once again begin to overpower gravitational forces) some of the pebble matter has not yet discharged.

This retained pebble matter stalls and eventually slides back to the vane peripheral. This 'carry over' is a major cause of pulp lifter inefficiency and also results in higher wear to lifter vane walls. Curved radial pulp lifters have been implemented to combat this discharge inefficiency. By curving the peripheral end of the vane, advantageous discharge angles are achieved much earlier in the mill rotation and consequently the discharging gravitational forces are realised more efficiently. However, curved pulp lifters are suitable for single directional rotation, so energy and wear advantages are often diminished because the mill cannot be rotated both clockwise and counter clockwise to extract the greatest operational life from internal lining plates.

Achieving the discharging efficiency of a curved radial system with the operational flexibility of the straight radial system could yield significant system benefits for mining operators.

7.3 Development of the JPAPL concept

7.3.1 Introduction

The JPAPL system concept was proposed to realise the collective benefits of the straight and curved radial pulp lifter system. Further, there was an opportunity to eliminate or minimise backflow by injecting high pressure water into the pulp lifter vane and forcing the contents more efficiently towards the discharge trunnion. If this action could be commercially realised two significant efficiency handicaps could be removed from the milling industry.

7.3.2 Concept hurdles

The idea of adding momentum to the pulp inside the pulp lifter vane presented some immediate design barriers. The first and most obvious was; how to introduce the pressurised water into the mill? This design obstacle consisted of two connected but separate component:

- 1) How to inject the fluid from the exterior of the mill into the lifter vanes.
and
- 2) How to sequence the distribution pulses to the injection ports.

And finally (accepting that in some kind of form an injection port would be required to inject the fluid pulses);

- 3) How to retain pulp from spraying out of these injection ports during the filling phase of the mill's rotation (6 o'clock to 9 o'clock.)

Developing practical solutions to these problems would be fundamental to any further development of the concept. The following sub-sections detail the process undertaken to analyse these problems and the solution path formulated.

7.3.3 Fluid injection

Determining a method to pass the fluid pulse from the exterior to the interior of the mill was the first design milestone. It would be important that whatever solution was selected that it be both reliable and low maintenance. As the injection ports would be permanently attached to the mill shell it would be essential the system operates trouble free for the proscribed planned shutdown duration.

To achieve a trouble free operating model I decided to keep the injection ports simple at the expense of complicating the fluid delivery system (which could be externally mounted and therefore removed and repaired if required while the system remained operational.) I decided to commence initial design development using a circular port penetrating from the exterior of the discharge head peripheral, centrally located in each vane and directed axially towards the discharge trunnion.

This basic injection port design yielded several distinct advantages:

- 1) Low cost of manufacture: Drilling/casting radial port holes through shell and liner components would be achievable at a minimal premium to existing manufacturing costs.
- 2) Low maintenance: The holes have no moving parts so problematic maintenance is eliminated.
- 3) Easily capped if the system was to be made redundant

With access established it was important to consider the implications of pulp leakage and fluid delivery.

7.3.4 Pulp leakage and water delivery

Further design development to solve both the distribution sequencing and pulp backflow through peripheral injection ports was developed in synergy with each other. It became apparent during conceptual development that any idea to overcome one limitation (pulp leakage for instance) lead to an integrated solution for the accompanying water deployment and sequencing issue.

Concepts that exhibited potential viability were developed to a preliminary draft level and tested against the following three parameters:

- 1) **Low maintenance:** Grinding systems run for long periods between shutdowns. The concept must be capable of operating for the life of the internal linings being used or the efficiency solution will reverse and become a maintenance liability for the user. The concept must be serviceable whilst the mill remains operational. By achieving this (if

maintenance is required) the user will only realise a system efficiency loss rather than the loss of production costs associated with a system shutdown.

- 2) **Commercial viability:** This would include the additional capital cost of manufacturing and installing the system, as well as the operational costs associated with power, maintenance and replacement.
- 3) **Improved efficiency:** This was tested by verifying the concepts met the evaluation criteria targets. In particular the JPAPL designs must comply with the evaluation scores issued during the design evaluation phase. In particular the design must be:
 - a. Compatible with Bi-Directional rotation
 - b. Reduce backflow and carryover
 - c. Improve pulp lifter discharge efficiency
 - d. Suitable with variable mill speeds
 - e. Reduce abrasive wear

The following three sub-sections identify the potential concepts and their testing compatibility.

7.4 JPAPL System #1:

The first concept solution utilised the initially problematic issue of peripheral pulp port discharge and applied it as a system integration advantage. It should be noted at this point that peripheral pulp discharge has been used with limited practical success in the grinding industry previously, however due to inefficient discharge consistency, the method is rarely used with commercial success.

As part of the JPAPL system#1 solution however, the poor performing peripheral discharge method presents an advantage in two ways. First by allowing (rather than trying to eliminate) the peripheral pulp discharge, a major design hurdle is removed. Secondly, peripheral port discharge would increase pulp removal and ultimately mill efficiency.

One of the major reasons why peripheral discharge performs poorly in industry currently is pulp packing in the lifter vanes. Due to the strong centrifugal forces applied to pulp and pebbles during rotation, particles can settle out of the pulp slurry solution and pack into the lifter vane peripheral corners. This is typically an area of low movement/flow so peripheral ports eventually rat hole and pack, resulting in reduced flow efficiency.

The JPAPL system overcomes this inefficiency by continually cleaning the lifter vanes by injecting high pressure water to push pulp towards the discharge trunnion. The pressurised water is held in one part of the external mill housing as shown in figure 7.1 As the lifters pass through this section of the revolution, the high pressure water flows through the injection ports and into the vanes. The location of the pressure hood could be trailed through various arc angle

of the mill rotation, however positioning it directly after zone 1 would ensure pulp backflow to be reduced by pushing pulp along the lifter before it can flow back into the mill.

It should be noted that figure 7.1 illustrates a unidirectional arrangement only, however the system could easily be adapted to a bidirectional system by replicating a the housing about the vertical plane.

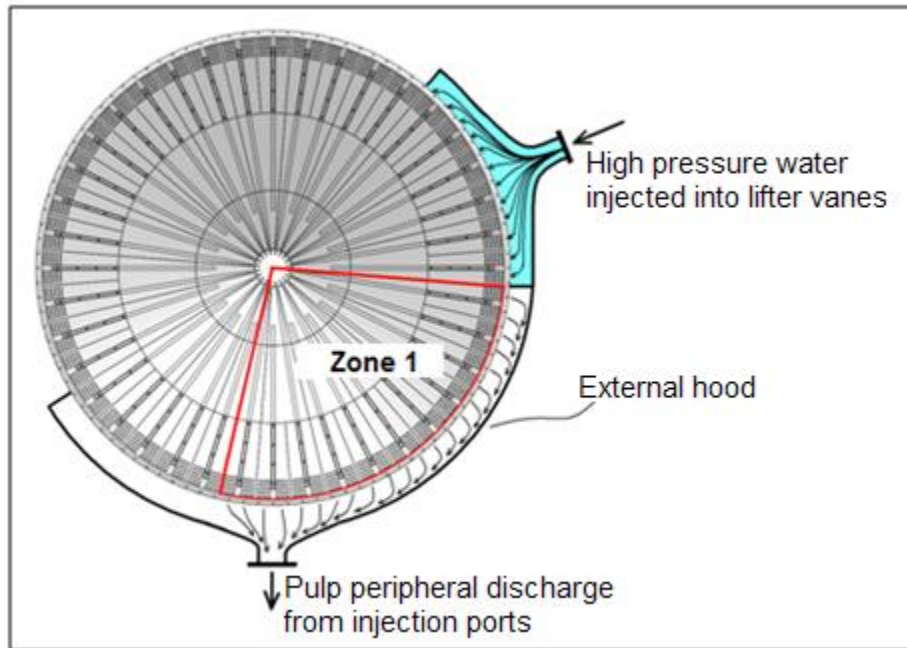

Figure 7.1: JPAPL System #1

7.4.1 System #1 Evaluation

Advantages:

- Increased pulp discharge (through both peripheral pulp flow and by eliminating carry-over.)
- Improved system efficiency (eliminating carry-over, and possibly reducing backflow through grates by driving pulp towards the trunnion earlier in the rotation.)
- Reduced wear (both from eliminating carry-over wear and the reduced pulp friction flow by adding a hydraulic water layer to the pulp motion)
- Low maintenance and few moving parts.

Limitations:

- **Achieving hydraulic seal:** For the system to operate effectively water must be held within the pressurised section of the housing. Achieving a seal against a large moving surface presents some difficulty and would require very accurate mill head manufacture and concentric alignment of the mill rotation. For all practical purposes this could be a commercially unachievable condition.

- **Seal wear:** Assuming the above manufacturing and installation tolerances could be achieved, the housing seals would be subject to high frictional wear from the stationary housing mating to the rotating mill. The friction could however be reduced by using the pressurised water as a hydraulic bearing for the seal. Again there is some question as to the commercial viability as the mating interface would require a prohibitively high degree of accuracy for such a large component.
- **Binding issues:** As the injection ports pass from zone 1 into the pressurised housing there is a possibility pulp pebbles could be discharging out the peripheral port and jam between the port and the housing seal. This event would result in a catastrophic failure of the seal and the pressure distribution system. This problem could potentially be addressed by using a scraper blade or a pre-wash system mounted from the high pressure housing.
- **Retro-fit adaptability:** This system would only be suitable for newly manufactured grinding mills, due to the high machining accuracy required to interface and seal the pressure housing.

7.5 JPAPL System #2:

System #2 tackles the peripheral pulp discharge by sealing the injection port through all angles of rotation except at the point/s where the pressurised water is injected into the system. The injection port seal would be achieved by fitting a steel plate (c/w mating gasket) inside the vane. The plate would be pinned against the vane wall end by both the centrifugal forces of rotation and spring forces produced by the two compression springs located around the domed driving bolts protruding out the exterior of the mill head as illustrated in figure 7.2 The domed bolts (in addition to retaining the compression springs) interface with an external guide frame, which drives the bolts axially down and pushes the sealing plate off the vane wall and opening up the injection port.

Injection of the pressurised water is provided by a spring loaded dispenser nozzle mounted to the guide frame. Water is released when the guide rollers (fixed to the nozzle) ride over the domed heads. The system achieves both the distribution and the sequencing of the water pulses. In the diagram only one water dispenser nozzle is shown, however an array of 5-10 nozzle would be required to effectively drive the pulp in the lifter to the discharge trunnion. This would easily be achieved by extending the curved guide frame to run concentric to the mill peripheral through a designated angle to allow multiple nozzles to be mounted to the frame. No specific details of the dispensing nozzle are provided for System #2. In later section of JPAPL concept, further development of the dispensing nozzle is considered.

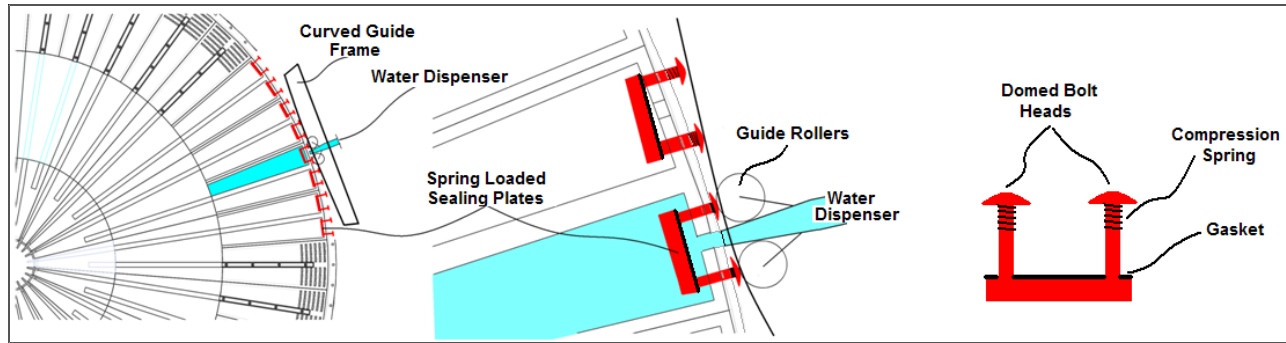

Figure 7.2: JPAPL System #2

7.5.1 SYSTEM #2 Evaluation

Advantages:

- Increased pulp discharge: Eliminating carry-over.
- Improved system efficiency: As per system #1.
- Reduced wear: As per system#1.
- Eliminating peripheral spray: Using the internal plate and external compression spring.
- Retro-fit compatible: System #2 could easily and cost effectively be retro-fit to any mill. Pulp lifters would be ordered with the injection port and bolt holes machined in, and a relatively basic site drilling process would be required to extend the holes through the discharge head wall. The external guide frame and water distribution assemblies would be manufactured and assembled off-site. The structural support would be designed and manufactured, then installed at the next shutdown.

Disadvantages:

- **High operational risk profile:** In contradiction to design criteria 7.3.4 item (1) the sealing plates represent some risk in the event of failure. If the domed bolts were to fatigue and shear off, the internal sealing plate would no longer be retained to the shell wall, but rather slide up and down the lifter through the mill rotation. Two scenarios would be of particular concern. First, the possibility that the sealing plate might jam at some point of the lifter vane, resulting in an impassable blockage of the vane. Secondly, and possibly more detrimental, is the potential for impact damage to the lifter vane walls. Unless the plate is small enough to discharge out the trunnion, it will continue to slide up and down the vane through the mill's rotation with the potential for high impact damage to liners.
- **High maintenance:** Both the sealing plate assembly and water jet distribution system would require regular preventative maintenance. To reduce the possibility of premature failure (and the consequences mention above) the domed bolts and compressions springs would require replacement at each shutdown. The water jet distribution system would be less of a concern as it could be removed at any point (even if the mill was

operating) and maintenance repairs performed. This stems from the fact the frame is externally mounted so could be lifted away from the system at any point. Further the sealing plates would simply remain closed without the guide frame to push down the bolts and open the injection port.

- **Poor sealing:** If pulp packing occurred around the sealing plate, it is possible that the plate may not correctly mate against the internal vane wall end. In this case pulp spray would leak out of the injector ports during rotation through zone 1 and represent a potential hazard to works and nearby equipment.
- **Misalignment of the injection sequencing:** The injection window using the domed head bolts to activate the water distribution system is very narrow, and has real potential that the water blasts might miss the port and be fired onto the external shell. This would not only render an expensive system ineffective, but also result in a large quantity of water spray around the mill area.

7.6 JPAPL System #3:

System #3 utilises similar concepts to system #2, but applied using different componentry. One of the main differences is the use of the rolling shell support ring. Larger SAG and AG style mills (which are the typical users of grate and pulp lifter discharge systems) have in recent years shifted away from trunnion supports and to a shell support. The reasons for this vary from greater structural support for the mill to lower casting accuracy requirements during head manufacturing. This concept system utilises the guide ring to further improve the application and distribution of the JPAPL system presented as System #2.

To control peripheral pulp discharge, System #3 uses rubber coated steel balls positioned in the Injection ports of the guide ring. The balls under the application of centrifugal forces press against the tapered injection ports and block pulp flow out of the lifter peripheral. Whilst engaged with the water dispensing system the high pressure water blasts drive the ball away from the tapered seat and allows water flow into the system (see figure 7.3) To restrict the ball falling into the lifter vane, the penetrations through the mill shell and the vane wall would need to be slotted (not round). Figure 7.3 and 7.4 illustrate how the injection ports are drilled into the guide ring. In this system, the height of the guide ring is utilised to junction the injection ports and enter them into the vanes at opposing corners. This would improve the driving efficiency of the JPAPL system as during the lifting rotation the pulp settles along vane walls (from the influence of gravity). Water injected into the system will always be working to push this settling pulp towards the discharge trunnion. Also, as the injections ports enter the vanes at both corners, the system becomes completely compatible with bi-directional rotation.

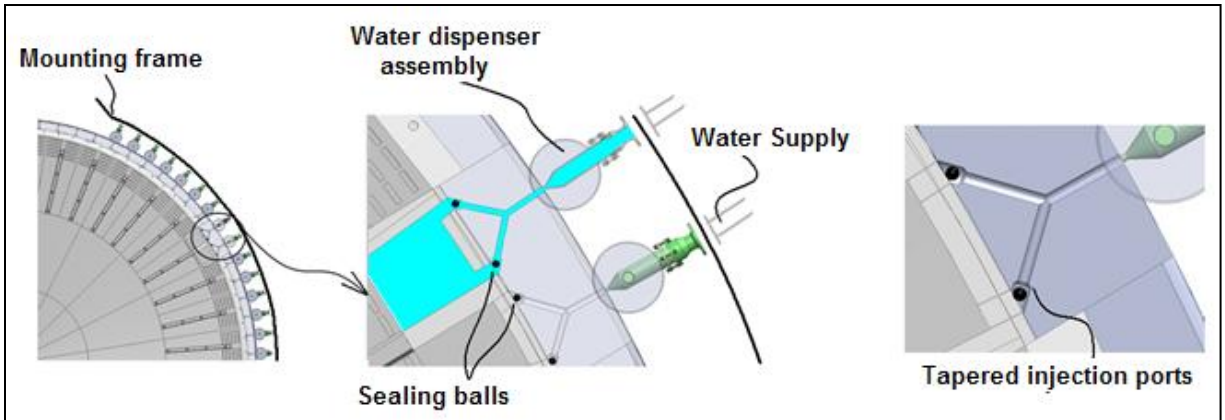

Figure 7.3: JPAPL System #3_Water injection

Synchronising delivery high pressure water to the port is also improved in System #3, by using a running contour path milled into the peripheral of the shell support ring as illustrated in figure 7.4. The contour path milled into the support ring would only be wide enough to locate a guide wheel, so support structural integrity would be unaffected. The milled contour will be smooth and sweeping enduring an extended water delivery blast will be produced. This will guarantee the water pulse is delivered into the injection ports.

Overspray will result from this sweeping contour path; however this overspray could easily be captured with a hood and collection sump. The water could then be filtered and pumped back into the system.

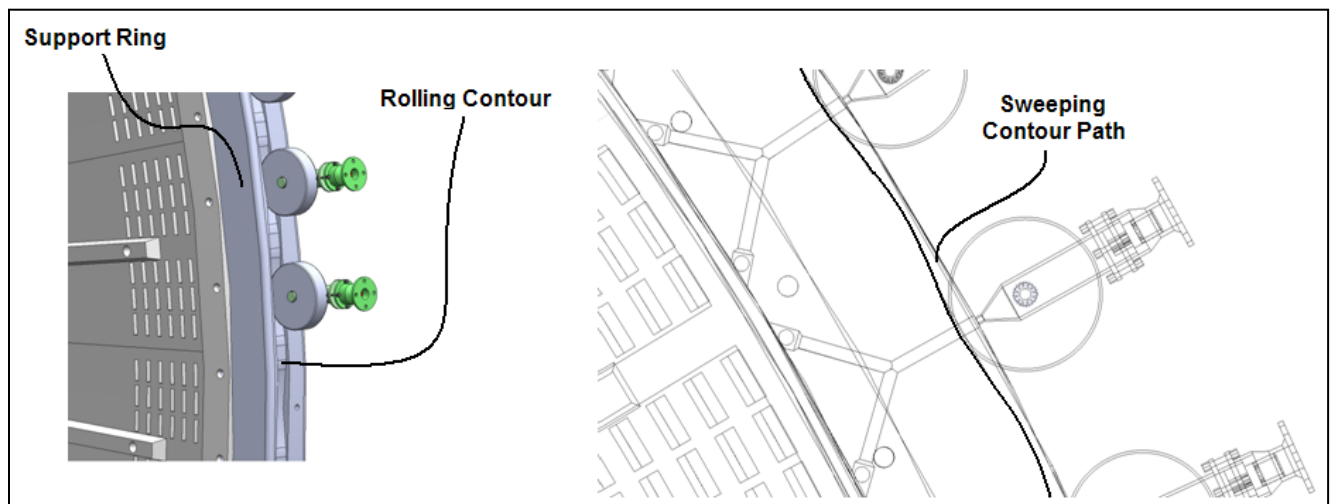

Figure 7.4: JPAPL System #3_Injection sequencing

The water dispenser components are detailed below in figure 7.5. The system uses internal water pressure to drive the rolling mate between the guide wheel and the shell support ring's contour path. Figure 7.6 and 7.7 illustrates how internal hydraulic pressure oscillates the lower

housing and guide wheel about the fixed flange connection (made to the external mounting frame.)

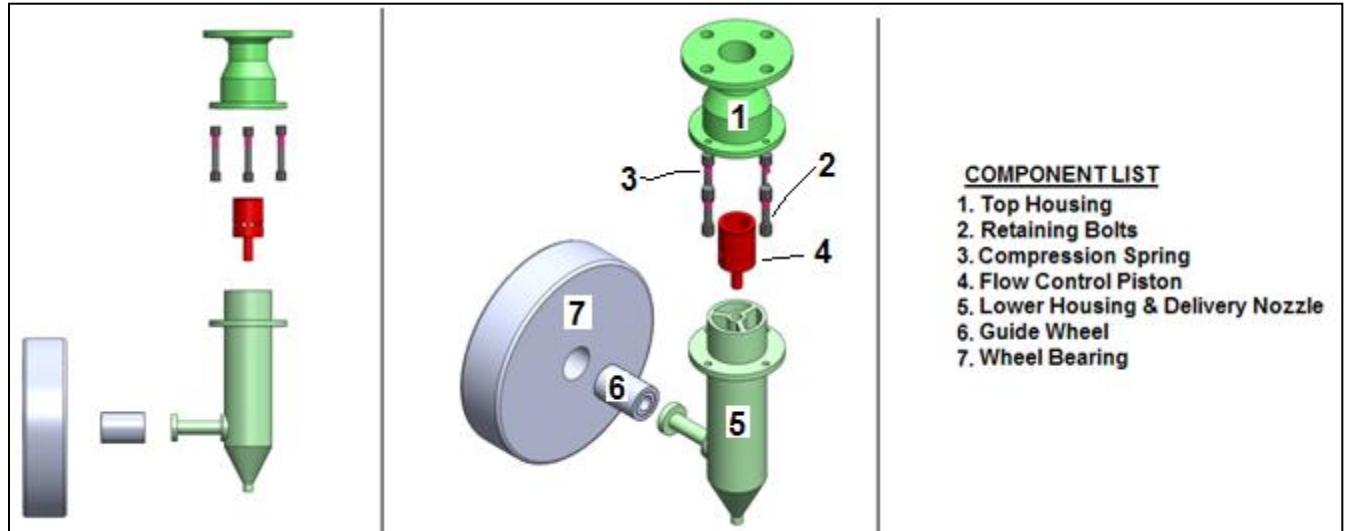

Figure 7.5: Water dispenser

While the system is pressurised, the force acting on the horizontal surfaces of the flow control piston push the movable components down. During the contour path's lows, holes drill radially around the flow control piston allow passage of the pressurised water to pass through the lower housing and into the injection port. Conversely, as the roller rides up the contour the lower housing (and piston) drives up, sealing the piston within the upper housing shaft and restricting fluid flow.

In the event the system loses water pressure, the compression springs on each of the retaining bolts retracts the wheel from the milled contour and into a disengaged shutdown state.

The array structure of the water delivery system also provides greater system control to the operator. When installed, pneumatic actuated flow control valves could be installed between the water dispenser assembly and the water supply. Connecting these valves to their PLC system, operators would be able to regulate the discharge capacity of the system. In the event harder ores were being delivered to the mill, less pulp discharge would result and consequently several of the water delivery units could be shut down. Also, operator could trial different combination of the water delivery system. Engaging water pulses earlier in the rotation (and possibly back into zone 1) could push the pulp down the vane, making room for greater pulp holding capacity. The system provides practical and measurable adjustment to the operator.

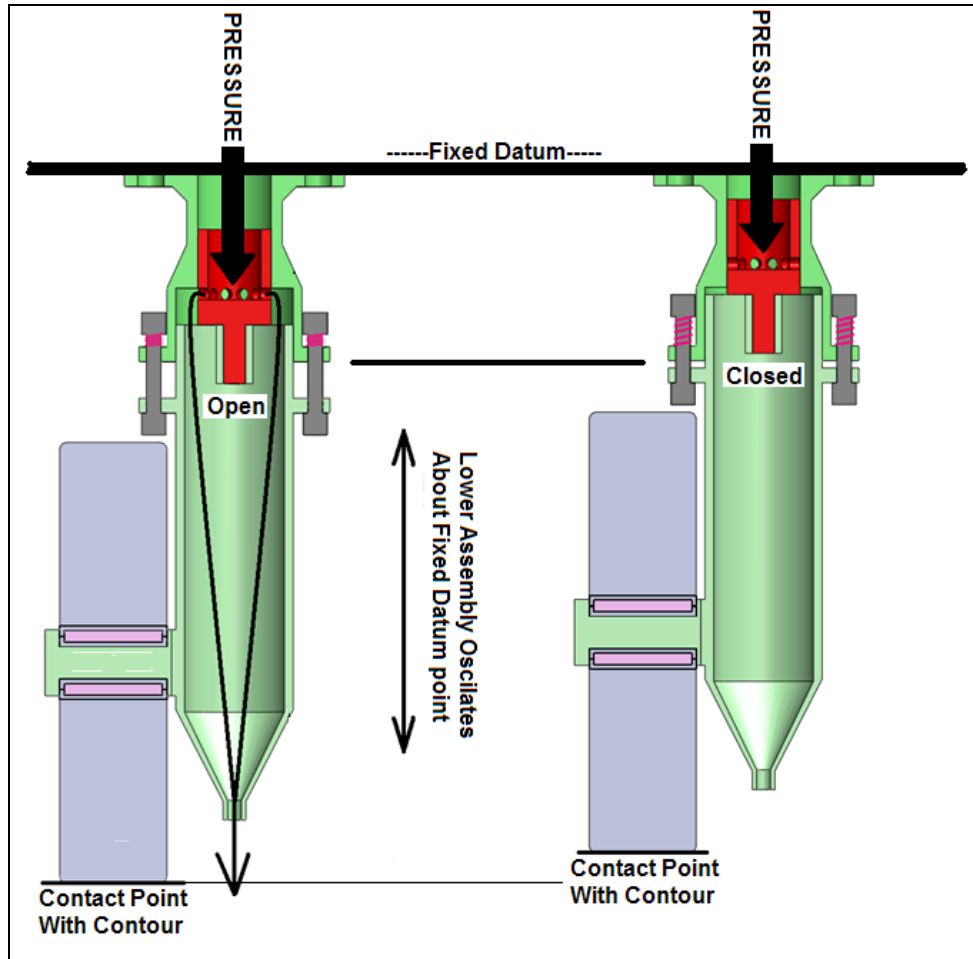

Figure 7.6: Water dispenser open/closed simulation

7.6.1 System #3 Evaluation

Advantages:

- Increased pulp discharge: Eliminating carry-over.
- Suitable for bi-directional rotation: Due to the split injection ports, system #3 operated with a maximum efficiency in either a CW or CCW rotation.
- Improved system efficiency: As per system #1.
- Reduced wear: As per system#1.
- Improved water jet delivery: Due to the rolling mate between the wheel and the guide contour, the pressurised water delivery is guaranteed to the injection ports.
- Greater system control: Operator can adjust the number and location of the water delivery by opening and shutting water supply to the system.
- Eliminate peripheral spray: By using the rubber lined steel balls peripheral pulp spray is eliminated. Further to this, (and because a spray hood would be required to catch pressurised water overspray) the hood would (in the event of a ball failure), catch any

peripheral pulp spray. The system could therefore continue to function effectively (without presenting an OH&S liability) until the next shutdown when the ball could be replaced.

Disadvantages:

- Limited application: The system requires the mill use a shell support ring. If the mill was trunnion supported, System #3 could still be used however at additional capital expense to the mine, as the support ring would be a dedicated cost to the JPAPL system.
- Maintenance: Because the pulp backflow control balls are housed within the support ring, access provisions would be required for change out. This could be achieved by drilling and tapping a port from the back of the rolling ring where the ball could be inserted or removed from. The tapped hole would be closed up using a steel bung.

Chapter 8

Recommendations and Conclusions

8.1 Introduction

The objective of this research paper was to identify 'system design improvement' to advance grinding mill efficiency used within the comminution industry. To varying degrees all of the concepts identified in this research paper achieve this and offer unique solutions to operational limitations. The commercial viability of these concepts however will require further research to validate the assumptions made during this research and the commercial viability of manufacture, implementation and operation of the solutions.

At a conceptual level however the following design combinations are presented to the reader as the system that represents the greatest benefits weighted against the evaluation tool's operational, commercial, Safety and environmental considerations.

8.2 Solution

The optimal design solution is a combination of both the RMSA and the JPAPL systems. The combination of both these concepts into the one mill, would potentially only be suitable for new or replacement milling circuits. This stems from the high replacement and configuration costs associated with modifying existing equipment to capitalise on the benefits of these designs.

Figure 8.1 offers a perspective model illustration of the final solution. The reader will notice the incorporation of three main designs:

- Removable dual shell arrangement
- Peripheral pulp discharge and collection hood
- JPAPL flushing system with spray hood.

Specific design details are identified in the following sections.

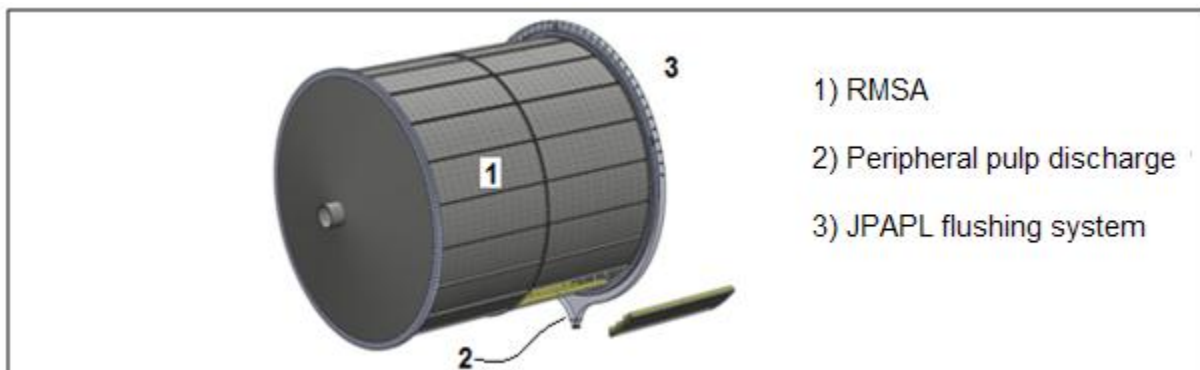

Figure 8.1: Optimal solution design

8.2.1 Dual Shell

The modular shell assembly is included in the final design to realise the operational and commercial advantages gained through faster shutdowns and the increased safety profile of this relining system. These advantages are well documented in section 6.

The *dual shell configuration* is selected for the increased structural rigidity during shell removal and particularly during emptying mill contents at the start of a shutdown. A dual shell system will not only allow for thinner shell construction materials (and ultimately lower capital costs) it will also significantly reduce the risk of shell buckling from the high bending stresses of the mill charge. Once the contents have been emptied (and due to the stronger structural profile), multiple shell components could be removed simultaneously to reduce the duration of the shutdown. The number of shells handled would be a function of structural capacity (which would require accurate stress modelling by the design engineers) and lifting capacity of the mine (double shell components could weigh upwards of 25 tonne and multi assemblies double that.)

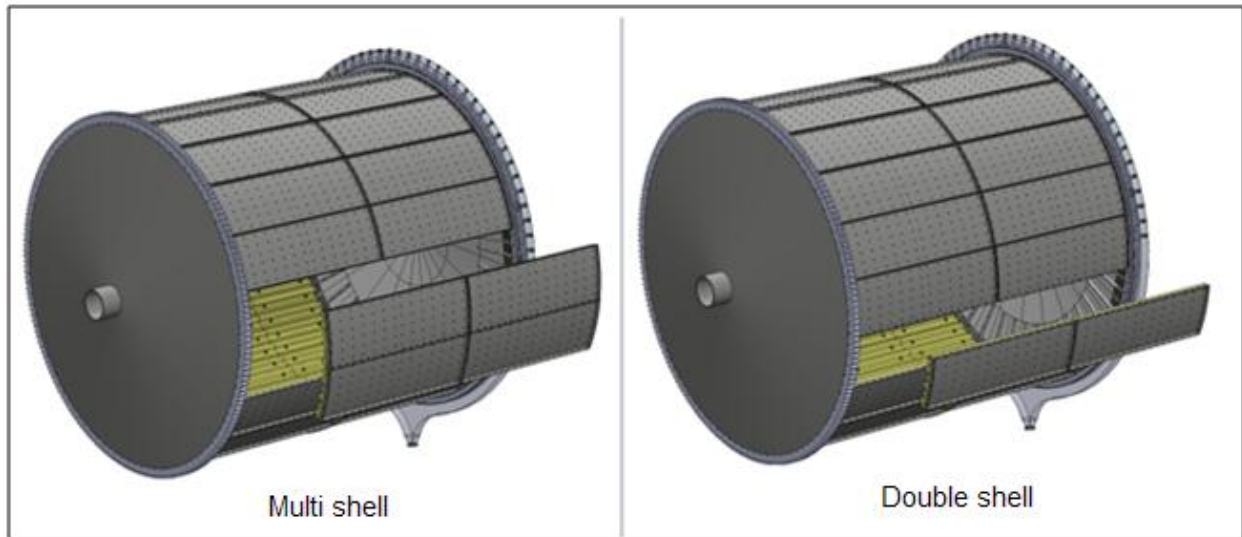

Figure 8.2: Shell removal

8.2.2 Peripheral spray hood and collection sump

To realise the optimum discharge efficiency the peripheral pulp discharge system has been incorporated into the final design. A pulp hood and sump is required to catch and control the discharge. To allow a maximum peripheral flow, no flow control device is included in the final solution (refer to solution '7.5 JPAPL System #2' and '7.6 JPAPL System #3'.) By eliminating flow control components both the manufacturing and maintenance cost profile is improved.

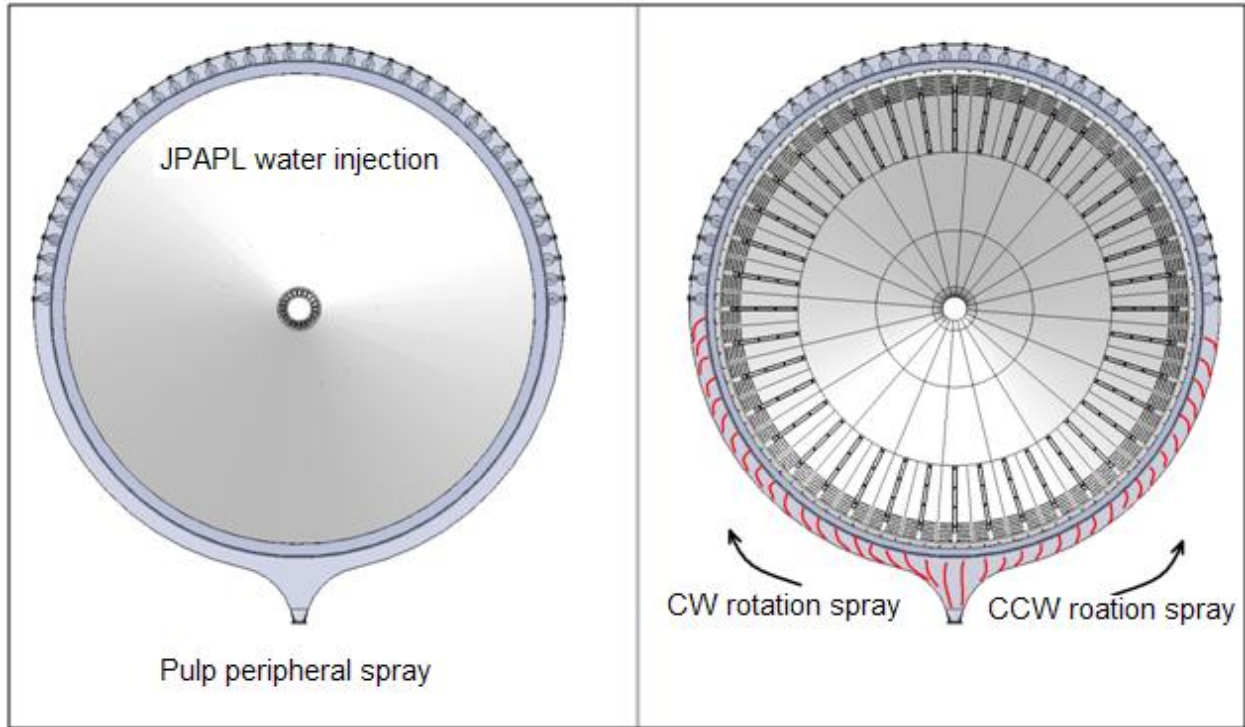

Figure 8.3: Discharge system

8.2.3 JPAPL bi-directional array

A contoured groove around the rolling ring (described in section 7.6 JPAPL System #3) is selected to provide the delivery synchronisation for the pressured water injection. The contour milling required at manufacture will increase the mine's capital investment; however the ongoing maintenance and operational profile of this system will be minimal due to the low impact oscillation of the rolling mate delivery. Further, the water overspray from the injection system will continuously wash and lubricate mating parts removing dust particles and reducing abrasive wear.

The water dispenser system as detailed in figure 7.5 is selected to provide the water injection into the pulp lifters. The hood being proposed to capture the peripheral pulp discharge will be extended completely around the mill providing both a mounting point for the water dispensers and a cover to capture water overspray from the sweeping contour delivery cycle. It should be noted at this point that the system has been extend across the top 180° of the mill (symmetrical about the vertical axis) making the system fully compatible with bi-directional rotation.

Due to the implementation of the peripheral pulp discharge method, consideration must be given to the possibility of component jamming as pulp discharging the port clashes with the approaching water distribution nozzle. To overcome this potentially disastrous system failure, the first three injection nozzles (in each direction) will be spaced off the injection port opening a distance of one times the diameter of the injection port (see figure 8.4). These three primary

water delivery nozzles will deliver pressurised water to the discharging pulp, cancelling the outward momentum created from centrifugal forces.

Prior to lowering the water delivery nozzles back to a closer locating tolerance, the forth water dispensing component (in each direction) will be replaced by a rolling hammer. This part (which is essentially a double rolling element ensures that any protruding particles are pushed back into the injection port prior to commencing pulp lifter flushing.

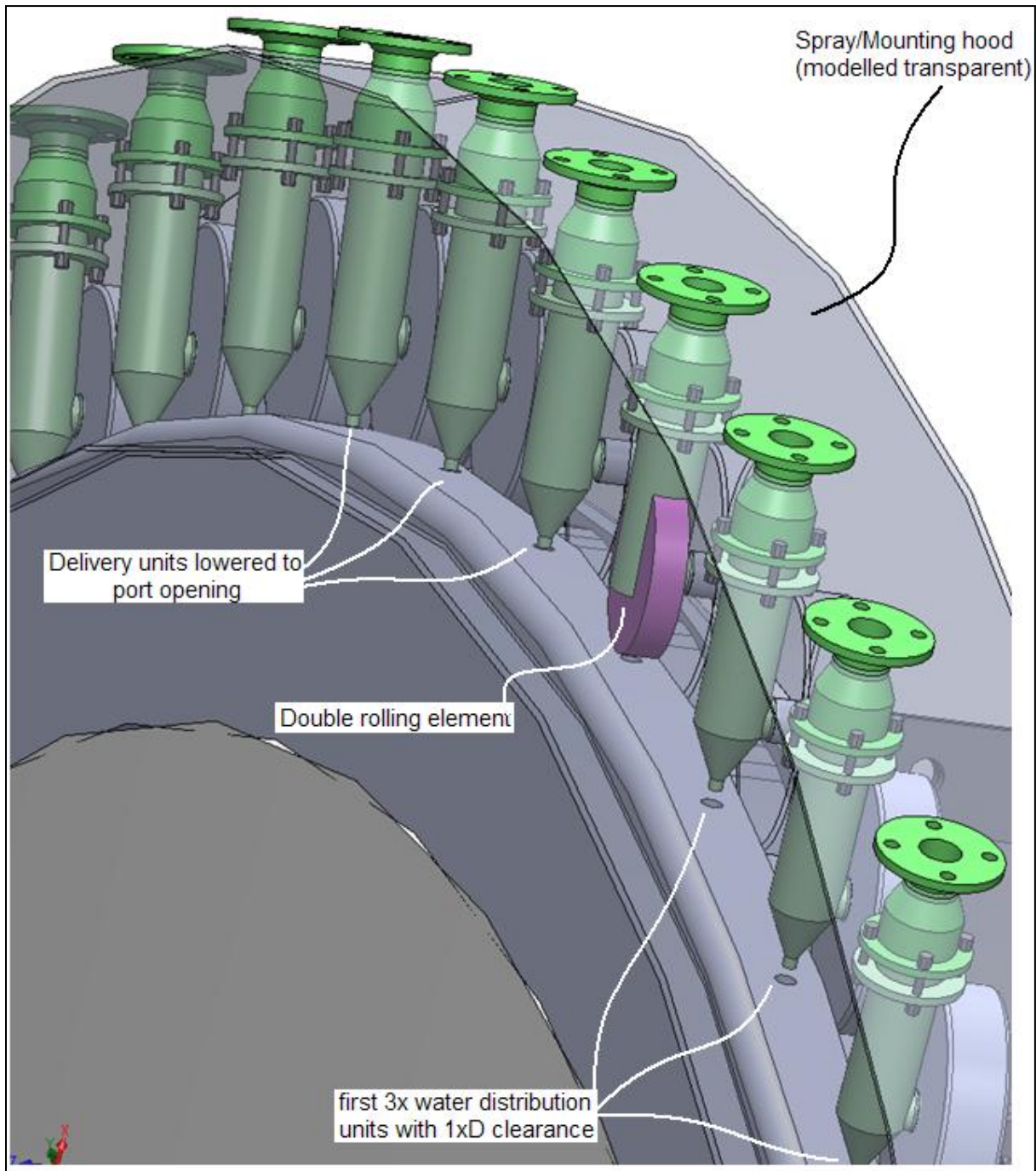

Figure 8.4: Water distribution system

Water delivery nozzles would be lowered to the rolling ring after the double rolling element hammer. With the risk of jamming removed, a closer locating nozzle will more effectively impart flushing momentum into the lifter vane. To facilitate mill operations, the water distribution array would be continued around the top half of the mill until meeting with the double rolling element positioned for the opposite rotation option. With this large number of water distribution units, operators could trial different injection combinations to determine the most effective JPAPL system. This would be achieved by using actuated valves at the flange connection outside the hood. Further to the process control, the large number of water distribution assemblies provides operations greater maintenance flexibility, as defective or damaged units could be shut off (which will then automatically retract off the rolling ring due to the compression spring, see figure 7.6) and adjacent water systems activated.

8.3 Solution review

The solution proposed tackles three limitations acknowledged in the current grinding mill industry:

- Commercial implications from relining shutdowns.
- Health and safety considerations of maintenance works.
- Discharging efficiency.

These three limitations are improved through the combined design configuration. The RMSA system (using dual shell) decreases shut down durations and reduces the need for crews to enter the mill during relining. The net gain is a safer relining system with a lower 'loss of production' profile. The combined peripheral discharge and JPAPL system increase discharge capacity of the mill, reduces the effects of backflow and eliminated the adverse wear and discharge implications of carry-over.

8.4 Further research

Due to the conceptual nature of this research project, at this stage the solutions presented have limited commercial validity. Further research and verification is required to determine if the designs do indeed provide commercially viable solutions to these long standing industry limitations. To assist interested reader, the following areas of research are included.

8.4.1 Design integration

One of the greatest difficulties encountered during this research was availability to accurate mill designs currently used in industry. To protect their intellectual property, designs are not freely distributed and much of the component integration used during this research was gleaned from diagrams and photos published in texts and on internet sites. Any further development of the concepts presented in this report will require availability to accurate model drawings to verify

integration with existing components. In particular, further research will need to investigate the RMSA system integration with the ring gear and also the shell rolling support. For the JPAPL and peripheral discharge system, accuracy of rotating alignment will need investigation to determine a suitable hood design and locating method to both catch pulp and water spray, and mount the water distribution units.

8.4.2 Structural analysis

Once component integration is verified, a final component can be designed. Part of this design process will require structural analysis, particularly focused on two fronts:

8.4.2.1 Shell analysis

Final design will require detailed investigation of bending and tensional strength of the shell and fixing components. Designers will need to determine construction thickness of the shell plates and flanges as well as fixing sizes and spacings. In addition, buckling simulations will need to be performed on plate removal for shutdowns. Detailed guidelines will need to be developed and supplied to users so that shell removal can be performed safely for both relining crews but also to ensure the mill is protected from damaging bending moments.

8.4.2.2 Water distribution

Large axial forces will be produced from internal fluid pressure within the water distribution units. The mounting hood design must be capable of anchoring the water distribution flange to ensure the rolling wheel is securely driven down onto the contour groove. Further the hood construction must be sufficiently sound to operate without vibration and movement that will affect the operation of the internal rolling components.

The water distribution assembly will require further design to determine flow rates, fluid velocities and buckling loads on the shell.

8.4.3 Commercial viability

Finally, the completed design can be tested for commercial viability. For the mill industry to embrace design development it must present some significant advantage. The concept designs proposed in this report will require a greater capital investment by mining organisations, so their measure of financial return will be in operational and maintenance saving across the total cost of ownership of the mill life. Detailed analysis and trials will be required to verify these savings and justify the investment return to the user.

8.5 Conclusion

The concepts presented in this research paper will undoubtedly require design manipulation before the benefits can be commercially realised. In their current conceptual form however, these ideas present a solution path to reduce or minimise inherent deficiencies hampering the grinding industry. With further research and development I hope these concepts will aid in improving this vital mining process and providing long term benefit to the comminution industry.

REFERENCES

- Fuerstenal M.C. & Han K.N. , (2003), Principles of Mineral Processing, John Wiley, New York, Viewed 21-23 April, 2010,
<http://books.google.com.au/books?id=38A9g7Ug3N4C&pg=PA770&lpg=PA770&dq=mill+grate+steep+pulp+gradient&source=bl&ots=Wbx6C60noL&sig=oYLD2SgL->
- Lane G, (2006), Sag Milling In Australia – Focus On The Future, Australian Journal of Mining, Volume 3, pg2
- Royston D, (2007), Semi-Autogenous grinding (SAG) mill liner design and development, Journal of Minerals and Metallurgical Processing, Volume 1, pg2-4
- Walker S, (2010), Liners for the Grinder, Engineering and Mining Journal, Article date 08 June 2010
<http://www.e-mj.com/index.php/features/410-liners-for-the-grinders.html>
- Zheng Y & Yang Y, (1997), Wear characteristics of large grinding balls in an SAG mill, 'Tribology Transactions', Article date October 1, 1997
- Gill C, (2005), New Technique Protects SAG Mills from the Daily Grind, Engineering and Mining Journal, Article date November 1, 2005

BIBLIOGRAPHY

- Brewis T, (1991), Grinding mills. (mill design and leading mill manufacturers), Mining Magazine, Article date, September 1, 1991
- Royston D, (2004), Review of recent experience with large-angle, wide-spaced shell lifter-liners, Mining Engineering Magazine, Article date, December 1, 2004
- Royston, D (2006), SAG mill pulp-lifter design, discharge and backflow, Mining Engineering Magazine, Article date, September 1, 2006
- Lane G & Siddall B, SAG MILLING IN AUSTRALIA – FOCUS ON THE FUTURE
Principal Process Engineer, GRD Minproc

Appendix A: Project Specification

University of Southern Queensland

FACULTY OF ENGINEERING AND SURVEYING

ENG 4111/4112 Research Project

PROJECT SPECIFICATION

FOR: Ian Gordon Commons-Fidge

TOPIC: Innovative design advancements to tumbling mill equipment used for communion in mining and mineral extraction processes.

SUPERVISOR/S: Steven Goh

ENROLMENT: ENG 4111 – S1, X, 2010
ENG 4112 – S2, X, 2010

PROJECT AIM: This project seeks to identify the major operational and economic deficiencies of tumbling mills currently used in the mining industry today and develop new innovative solutions to improve their efficiency while reducing operating costs.

SPONSORSHIP: Faculty sponsored

PROGRAMME: Issue A, 18th March 2010

PROJECT AIM:

1. Research types of rotating ball mills currently used in industry.
2. Identify critical ball mill operating parameters and investigate how these parameters affect performance.
3. Investigate industry concerns regarding ball mill use, their efficiency and cost of operation.
4. Using research results develop a deficiency list for ball mill equipment.
5. Develop conceptual design improvements to overcome significant deficiencies identified

If time permits;

6. Consult industry (mill manufactures, end users, and engineering design firms) to discuss design changes and the practicality of implementation.



(Student)

23 / 05 / 10



(Supervisors)

30 / 05 / 10

Examiner/Co-examiner: _____

Appendix B: Concept diagrams

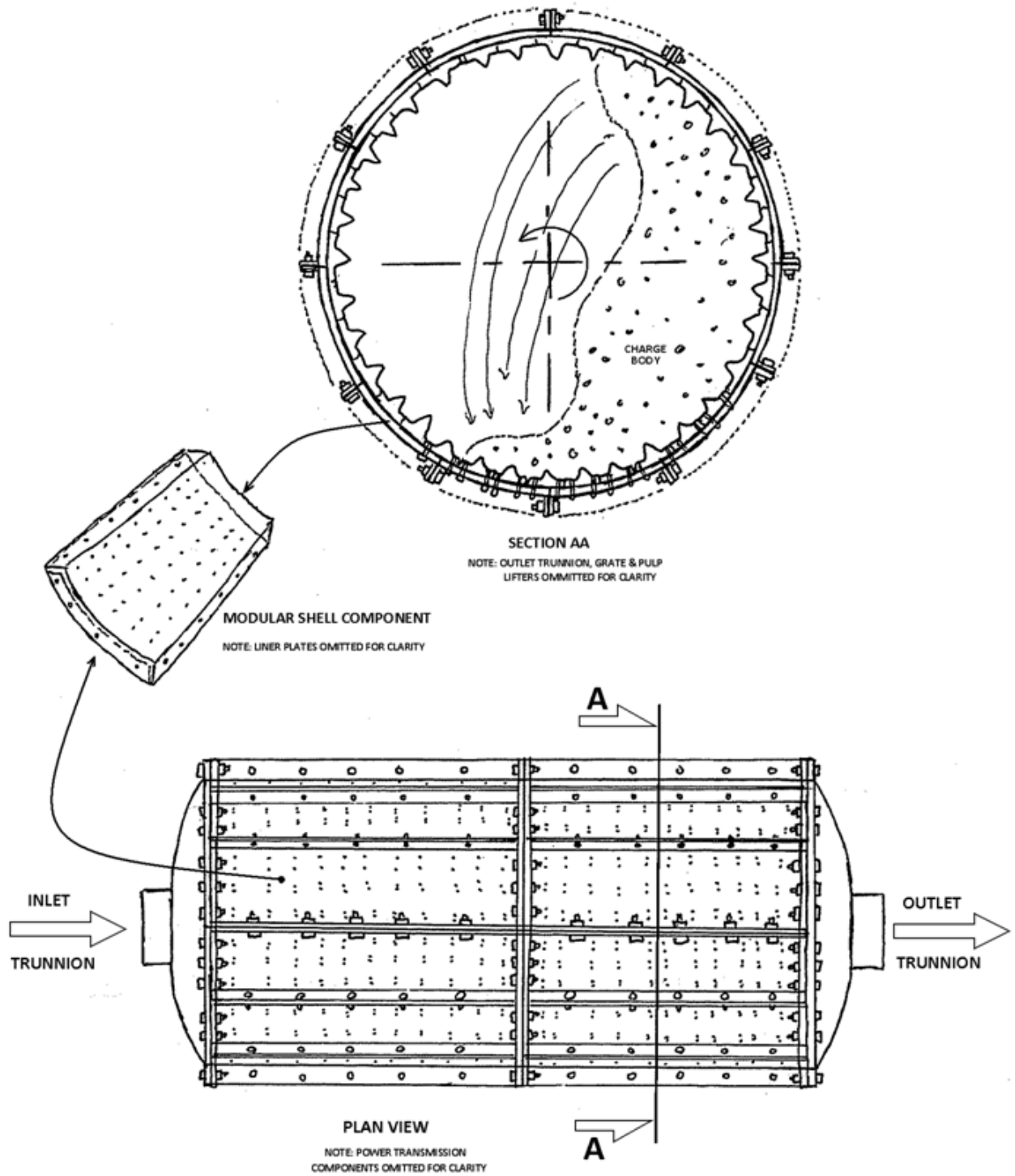
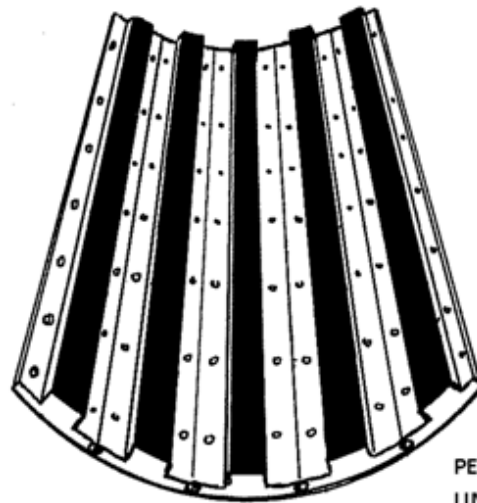
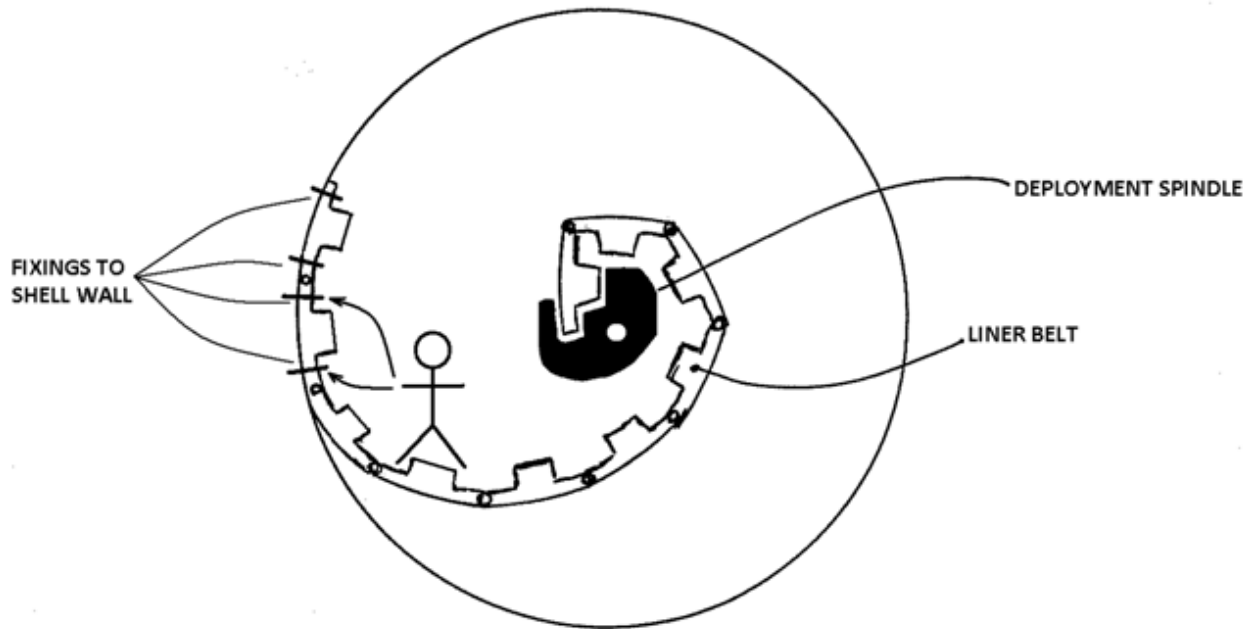

Figure 4.1: Removable Modular Shell Assembly



PERSPECTIVE VIEW OF
LINER BELT SECTION

NOTE: MILL SHELL OMITTED FOR
CLARITY



SECTIONAL END VIEW OF
LINER BELT INSTALLATION

NOTE: ALL INTERNAL COMPONENTS
OMITTED FOR CLARITY

Figure 4.2: Hinged Liner Belt

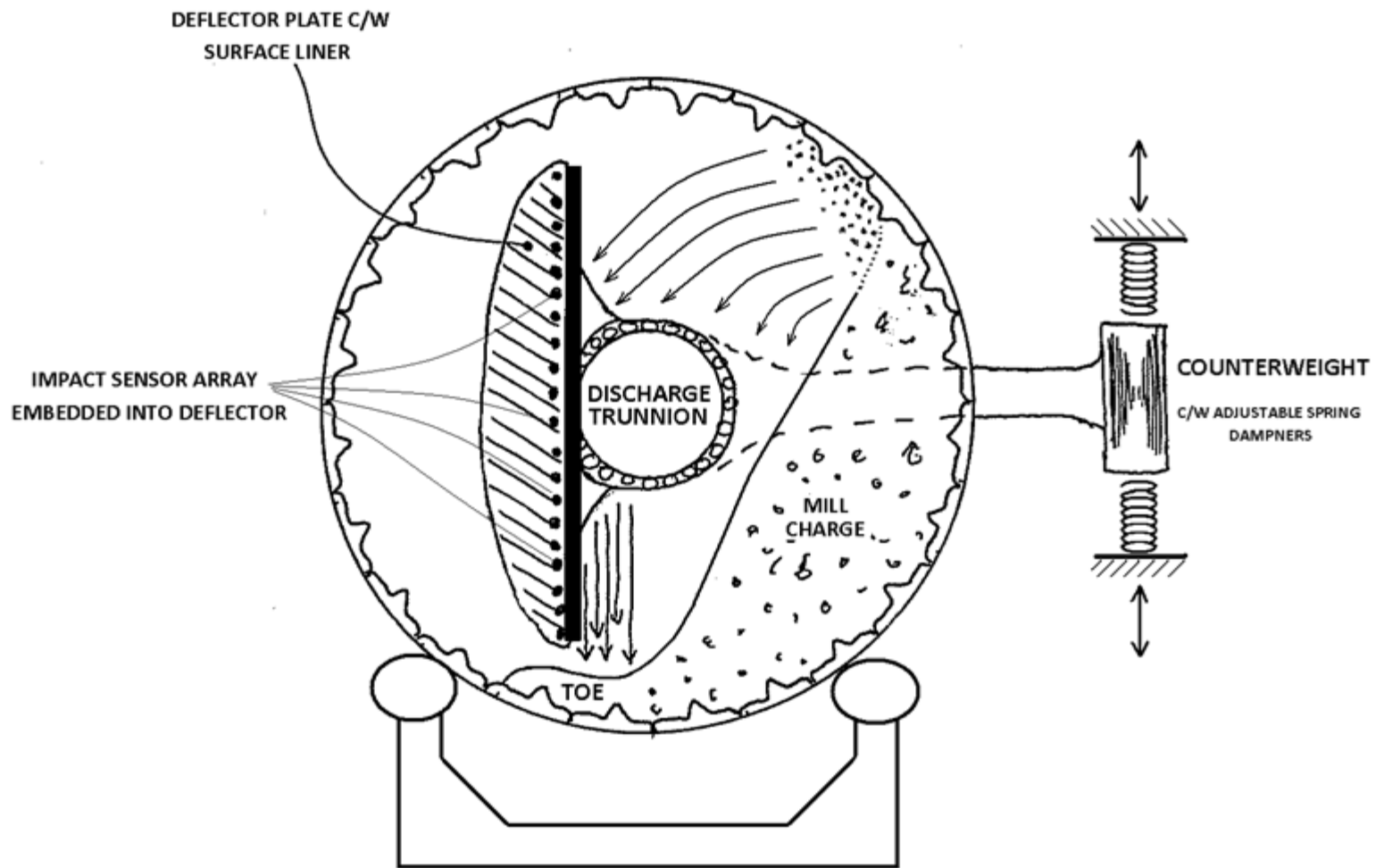

SECTIONAL END VIEW OF MILL WITH
ADJUSTABLE DEFLECTOR PLATE

NOTE: BEARING SUPPORT INCLUDED FOR
ILLUSTRATIVE PURPOSES ONLY

Figure 4.3: Adjustable Deflector Plate

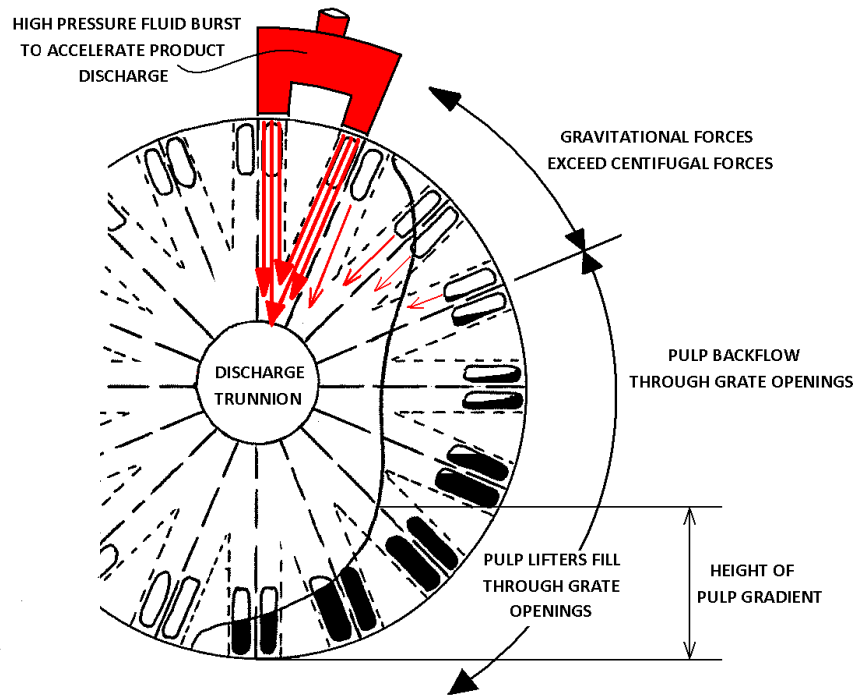
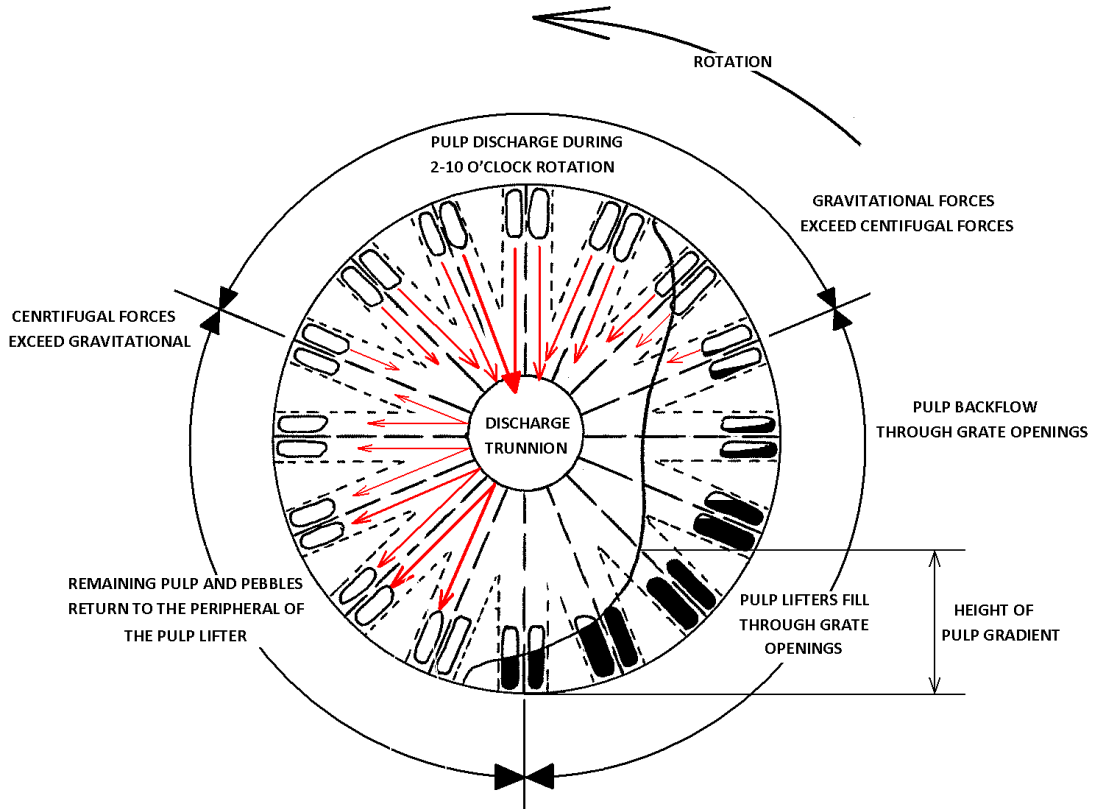

Figure 4.4: Jet Propulsion Assisted Pulp Lifter

Appendix C: Design concept evaluation form

#1_Modular Shell Liner System

DESIGN CONCEPT EVALUATION FOR:

Description	Weight	Pass	Fail	Score
OPERATION				
Bi-Directional Capability	3	X		3
Increase pulp transfer through grate openings	1		X	0
Reduce pulp Backflow	3		X	0
Improves Pulp Lifter discharge efficiency	3		X	0
Suitable with variable mill speeds	3	X		3
Suitable with variable charge volumes	1	X		1
Suitable with variable ball sizes	1	X		1
Compatible with overflow discharge systems	2	X		2
Compatible with Grate & Pulp lifters systems	2	X		2
Compatible with trunnion supported mills	2	X		2
Compatible with shell support mills	2	X		2
Compatible with wet grinding	2	X		2
Compatible with audio sensory equipment	2	X		2
Reduced abrasive wear	3		X	0
Reduced impact damage	2		X	0
Reducing charge slippage	2		X	0
Improve charge control	3		X	0
COMMERCIAL				
Reduce shut down duration	4	X		4
Reduce requirement for specialist shut-down contractors/ equipment	2	X		2
Increase production per unit operating cost	4	X		4
Increase production per unit maintenance cost	4	X		4
Adaptability/retro-fit to existing equipment	5		X	0
Decrease capital cost for new equipment	1		X	0
OH&S				
Reduce Loss Time Injury (LTI) risk for:				
Operation	3		X	0
Maintenance	3	X		3
Reducing sound emissions	1		X	0
ENVIRONMENTAL				
Reduce consumption of operational consumables per tonne output	2		X	0
Improve energy efficiency of the grinding system	3		X	0

TOTAL 37

DESIGN CONCEPT EVALUATION FOR:

#2_Hinged Liner Belt

Description	Weight	Pass	Fail	Score
OPERATION				
Bi-Directional Capability	3	X		3
Increase pulp transfer through grate openings	1		X	0
Reduce pulp Backflow	3		X	0
Improves Pulp Lifter discharge efficiency	3		X	0
Suitable with variable mill speeds	3	X		3
Suitable with variable charge volumes	1	X		1
Suitable with variable ball sizes	1	X		1
Compatible with overflow discharge systems	2	X		2
Compatible with Grate & Pulp lifters systems	2	X		2
Compatible with trunnion supported mills	2	X		2
Compatible with shell support mills	2	X		2
Compatible with wet grinding	2	X		2
Compatible with audio sensory equipment	2	X		2
Reduced abrasive wear	3		X	0
Reduced impact damage	2		X	0
Reducing charge slippage	2		X	0
Improve charge control	3		X	0
COMMERCIAL				
Reduce shut down duration	4	X		4
Reduce requirement for specialist shut-down contractors/ equipment	2		X	0
Increase production per unit operating cost	4		X	0
Increase production per unit maintenance cost	4	X		4
Adaptability/retro-fit to existing equipment	5	X		5
Decrease capital cost for new equipment	1		X	0
OH&S				
Reduce Loss Time Injury (LTI) risk for:				
Operation	3		X	0
Maintenance	3		X	0
Reducing sound emissions	1		X	0
ENVIRONMENTAL				
Reduce consumption of operational consumables per tonne output	2		X	0
Improve energy efficiency of the grinding system	3		X	0

TOTAL 33

DESIGN CONCEPT EVALUATION FOR: #3_Adjustable Deflector Plate

Description	Weight	Pass	Fail	Score
OPERATION				
Bi-Directional Capability	3		X	0
Increase pulp transfer through grate openings	1		X	0
Reduce pulp Backflow	3		X	0
Improves Pulp Lifter discharge efficiency	3		X	0
Suitable with variable mill speeds	3	X		3
Suitable with variable charge volumes	1	X		1
Suitable with variable ball sizes	1	X		1
Compatible with overflow discharge systems	2	X		2
Compatible with Grate & Pulp lifters systems	2		X	0
Compatible with trunnion supported mills	2	X		2
Compatible with shell support mills	2	X		2
Compatible with wet grinding	2	X		2
Compatible with audio sensory equipment	2	X		2
Reduced abrasive wear	3		X	0
Reduced impact damage	2	X		2
Reducing charge slippage	2		X	0
Improve charge control	3	X		3
COMMERCIAL				
Reduce shut down duration	4		X	0
Reduce requirement for specialist shut-down contractors/ equipment	2		X	0
Increase production per unit operating cost	4	X		4
Increase production per unit maintenance cost	4		X	0
Adaptability/retro-fit to existing equipment	5		X	0
Decrease capital cost for new equipment	1		X	0
OH&S				
Reduce Loss Time Injury (LTI) risk for:				
Operation	3		X	0
Maintenance	3		X	0
Reducing sound emissions	1	X		1
ENVIRONMENTAL				
Reduce consumption of operational consumables per tonne output	2	X		2
Improve energy efficiency of the grinding system	3	X		3

TOTAL 30

DESIGN CONCEPT EVALUATION FOR:

#4_Pulp Discharge Jet

Description	Weight	Pass	Fail	Score
OPERATION				
Bi-Directional Capability	3	X		3
Increase pulp transfer through grate openings	1	X		1
Reduce pulp Backflow	3	X		3
Improves Pulp Lifter discharge efficiency	3	X		3
Suitable with variable mill speeds	3	X		3
Suitable with variable charge volumes	1	X		1
Suitable with variable ball sizes	1	X		1
Compatible with overflow discharge systems	2		X	0
Compatible with Grate & Pulp lifters systems	2	X		2
Compatible with trunnion supported mills	2	X		2
Compatible with shell support mills	2	X		2
Compatible with wet grinding	2	X		2
Compatible with audio sensory equipment	2	X		2
Reduced abrasive wear	3	X		3
Reduced impact damage	2		X	0
Reducing charge slippage	2		X	0
Improve charge control	3		X	0
COMMERCIAL				
Reduce shut down duration	4		X	0
Reduce requirement for specialist shut-down contractors/ equipment	2		X	0
Increase production per unit operating cost	4	X		4
Increase production per unit maintenance cost	4	X		4
Adaptability/retro-fit to existing equipment	5	X		5
Decrease capital cost for new equipment	1		X	0
OH&S				
<i>Reduce Loss Time Injury (LTI) risk for:</i>				
Operation	3		X	0
Maintenance	3		X	0
Reducing sound emissions	1		X	0
ENVIRONMENTAL				
Reduce consumption of operational consumables per tonne output	2		X	0
Improve energy efficiency of the grinding system	3	X		3

TOTAL 44