

University of Southern Queensland
Faculty of Engineering & Surveying

**Design and Development of a Prototype, Small Plot
Research Harvesting System**

A Dissertation submitted by

Justin Schultz

in fulfilment of the requirements of

ENG4112 Research Project

towards the degree of

Bachelor of Engineering (Agriculture)

Submitted: October, 2005

Abstract

It has been estimated that the cost of black point damage for Austrealian wheat industry are up to \$50 million each year in down-graded wheat. Similarly in barley, the loss of income for the farmer in the down-graded barley can be in-excess of \$50 per tonne of grain from malting quality to feed grain.

Currently a research project which involves the DPI& F in Toowoomba, Queensland, have discovered that the traditional explanation for black point may not be correct. Currently the research project is looking at finding molecular markers in suspectable varieties and trying to breed that marker out of new lines of wheat and barley.

To achieve this task the DPI& F plant small plots of wheat and barley each year and manage the crop to induce conditions favorable to black point in an aim to try and determine the resistance of each variety to black point. In doing so the DPI& F last year planted 4400 wheat plots and a similar amount of barley plots. Due to the small size of the plots and the large number of them, harvesting the trials becomes inefficient and expensive. Some of the OH&S risks are repetitive stress of bending, use of a sharp open bladed sickle, exposure to dust during thrashing, use of a thrasher and the mechanical parts of the thrasher and extended exposure of ultra violet radiation to bodily skin.

This project is aimed at increasing the efficiency of the harvesting of the trial plots. In doing this the project will aim at mechanizing the cutting and thrashing process into one simple portable device. This will reduce the transportation of unwanted crop residues and will reduce the time spent in the field collecting and thrashing the trials. Many of the OH&S risks associated with the harvesting process may also be eliminated.

The system that has been designed features a beater type thrashing system where the grain is thrashed while still on the plant. The removed plant material is conveyed to a aspirator where separation of the grain and husks takes place. It is shown that the system has performed well and according to the design specifications. The system is compact and light and is quite efficient in the collection and time spent collecting.

Other advantages for the new system are the reduced costs involved in harvesting the research plots. The light weight system that only takes the grain from the plot. The system avoids contamination due the self cleaning nature of the system. Has an accurate separation system to ensure that no research data is lost. Finally the system has the potential to collect both trash and grain to improve efficiency for the plots in the following year.

The system has been designed with some unique features. One of these features is the beater collection of the grain. In the system a beater removes the grain from the plant, this beater replaces the cutting and thrashing section of a standard combine harvester. Other features are the use of one single fan to both convey and separate the harvested material and the incorporation of existing commercial off the shelf components.

University of Southern Queensland
Faculty of Engineering and Surveying

ENG4111/2 *Research Project*

Limitations of Use

The Council of the University of Southern Queensland, its Faculty of Engineering and Surveying, and the staff of the University of Southern Queensland, do not accept any responsibility for the truth, accuracy or completeness of material contained within or associated with this dissertation.

Persons using all or any part of this material do so at their own risk, and not at the risk of the Council of the University of Southern Queensland, its Faculty of Engineering and Surveying or the staff of the University of Southern Queensland.

This dissertation reports an educational exercise and has no purpose or validity beyond this exercise. The sole purpose of the course pair entitled “Research Project” is to contribute to the overall education within the student’s chosen degree program. This document, the associated hardware, software, drawings, and other material set out in the associated appendices should not be used for any other purpose: if they are so used, it is entirely at the risk of the user.

Prof G Baker

Dean

Faculty of Engineering and Surveying

Certification of Dissertation

I certify that the ideas, designs and experimental work, results, analyses and conclusions set out in this dissertation are entirely my own effort, except where otherwise indicated and acknowledged.

I further certify that the work is original and has not been previously submitted for assessment in any other course or institution, except where specifically stated.

JUSTIN SCHULTZ

0012220068

Signature

Date

Acknowledgments

First and foremost I must acknowledge the one who created the universe. Without the Lord all is in vain.

I would like to acknowledge the efforts and support of all the staff at Biosystems Engineering, especially Mr Richard Sulman , who assisted in numerous ways.

Thanks also to my supervisors Dr. Guang Chen and Mr Richard Sulman for their support and guidance throughout the course of this project.

I would also like to thank my wife Sharon, for all her love and support.

JUSTIN SCHULTZ

University of Southern Queensland

October 2005

Contents

Abstract	i
Acknowledgments	v
List of Figures	xi
List of Tables	xiv
Glossary	xv
Chapter 1 Introduction	1
1.1 The Australian Wheat Industry	1
1.1.1 Wheat and Barley Production in Australia	1
1.2 Research of Black Point	2
1.2.1 Cost of Black Point to the Grain Industry	2
1.2.2 Difficulties of Current Harvesting Process	3
1.2.3 Set up of plots	3
1.3 Methodology	8

Chapter 2 Previous Research	10
2.1 Mechanical Properties of Wheat and Wheat Residues	10
2.2 Harvesting Methods	11
2.2.1 Grain removal from plants	13
2.2.2 Conveyance systems to the thrasher	16
2.2.3 Threshing systems	17
2.2.4 Cleaning or Separation of Grains from Plant material	22
2.3 Existing Systems	25
2.3.1 Single Row or Plant, Combine Harvesting Machine	25
2.3.2 Kingaroy Engineering Works Plot Harvesters	26
2.3.3 KEW Walk-Behind Thrashers	27
2.3.4 Large Scale Combine Harvesters	28
Chapter 3 Aims of the Portable Harvesting System	29
3.1 Purpose of Hill Trial Plots	29
3.2 Scope of the Hand Held Harvesting System	30
3.3 Secondary Design Requirements	31
3.4 Design Methodology	32
3.4.1 Introduction	32
3.4.2 Prototype Design	32
3.4.3 Prototype Building	34

3.4.4	Prototype testing	34
3.4.5	Prototype Evaluation	34
3.4.6	Optimization	35
Chapter 4 Possible Designs		36
4.1	Critical Elements of System	36
4.2	Removal of Grain From The Crop	37
4.2.1	Grass Trimmer	37
4.2.2	Beater Front Principle	40
4.3	Thrashing	42
4.3.1	Belt Thrasher	42
4.3.2	Line Trimmer Cord, Beater	43
4.3.3	Circular Rice De-Husker	43
4.4	Separation	44
4.4.1	Cyclone Aspirator	45
4.4.2	Horizontal Sorting Chamber or Fluidized Bed	46
4.4.3	Vibration Table	47
4.4.4	Aspirators	48
4.5	Analysis and Discussion of Proposed System	49
4.6	Conclusion	51

Chapter 5 System Design	52
5.1 Introduction	52
5.2 Fan Curve	53
5.3 Vertical Air Stream Sorting Chamber	57
5.4 Pneumatic Design	60
5.4.1 Splitting Device	60
5.4.2 Induction Device	62
5.4.3 Diffusing Device	64
5.4.4 Fluid Exit	69
5.5 Conclusion	71
Chapter 6 System Testing and Evaluation	73
6.1 Introduction	73
6.2 System Testing	73
6.2.1 Beater Type Handpiece Testing	74
6.2.2 Pneumatic and Diffusing System Testing	75
6.3 System Evaluation	79
6.3.1 Cost of the Prototype	80
6.3.2 Beater Type Handpiece Evaluation	80
6.3.3 Pneumatic System	83
6.3.4 Sorting Chamber	87

6.4 Conclusion	88
Chapter 7 Recommendations for Prototype Improvements	90
7.1 Prototype Improvements	90
7.1.1 Pneumatic System Improvements	90
7.1.2 Handpiece Improvements	92
7.1.3 Sorting Chamber Improvements	93
7.1.4 Overall Improvements	94
Chapter 8 Conclusions	96
References	98
Appendix A Appendix A	100
Appendix B Prototype Design Drawings	103

List of Figures

1.1	Picture of a hill plot trial, early stage of growth.	4
1.2	Picture of a hill plot trial, late stage of growth	5
1.3	Picture of a hill plot trial for barley, late stage of growth	6
1.4	Picture of a hill plot trial for barley, Gathering the plot together.	7
2.1	Schematic of an early John Deere Combine ([Griffin, 1973,] pp 51,)	12
2.2	Schematic of the Front Cutter Bar of a KEW Plot Harvester	14
2.3	Schematic of the stripper elements ([Tado, Wacker, Kutzbach & Sumministrado, 1998,] pp 107,)	15
2.4	Schematic of a feed unit ([Griffin, 1973,] pp 24,)	16
2.5	Concept of the thrashing system for a CX Series New Holland ([Case New Holland Australia Web Site, 2005])	18
2.6	Concept of the spike and tooth thrashing system ([Griffin, 1973,] pp 31,)	19

2.7	Diagram of an Axial Thrasher ([Case New Holland Australia Web Site, 2005])	20
2.8	Schematic of the Rubber Roller Dehuller ([Houston D.F., 1972] pp 192,)	21
2.9	Schematic of the Circular Disk Dehuller ([Houston D.F., 1972] pp 193,)	22
2.10	Diagram of the John Deere Cleaning System ([John Deere Australia Web Site, 2005,])	23
2.11	Diagram of the Single Row Harvester ([Calvin & Davis 2000])	26
2.12	Picture of the Rear View of a KEW Plot Harvester	27
4.1	Diagram of an Ozito Hedge trimmer with safe guards	39
4.2	Initial Prototype of Beater Principle	41
4.3	Picture of one of the samples taken of the Horizontal Sorting Chamber	51
5.1	Pitot Tube Velocity Sensor ([Chadwick, Morfett & Borthwick, 2004,] pp 43,)	54
5.2	Viking Fan Curve	56
5.3	Prototype of the Sorting Chamber	59
5.4	Sectional view of the Air stream Splitting System	62
5.5	Sectional view of a Venturi and associated pressure ([Chadwick, Morfett & Borthwick, 2004,] pp 44,)	63

5.6	Sectional view of a typical venturi ([Klinzing, Marcus, Rizk F. & Leung, 1997,] pp 247,)	64
5.7	Sectional view of a cyclone (Taken from Davis & Cornwell pp526)	66
5.8	Pictorial of the Sorting System	69
6.1	The full prototype as a working system.	77
6.2	Seed sample from the sorting chamber.	78
6.3	A view inside the beater handpiece design.	82
6.4	The Prototype Handpiece showing the Fluid Entry Point	86
7.1	Figure showing the recommended pneumatic set up	92
7.2	Figure showing the recommended handpiece	93
7.3	The rear view of the trolley set up	94
7.4	Picture showing the full recommended system	95

List of Tables

2.1	Mechanical Properties of Grain and Plant Material [Mohsenin, 1986,] (pp 251, 642, 643.)	11
5.1	Measured data for fan curve	55
5.2	Velocity versus pressure head, calculated for fan curve.	55
5.3	Discharge versus pressure head, calculated for fan curve	56
5.4	Dimension Ratios for a Standard Cyclone (Taken from Davis & Cornwell pp526)	66
5.5	Dimension for a Standard 250mm Cyclone	68
6.1	Measured velocities of airstreams in the system	79
6.2	Cost of the Prototype, broken down into components	80

Glossary

<i>Black Point</i>	Discolouration in the germ end of a wheat or barley grain
<i>Combine Harvester</i>	A machine that collects the grain and thrashes it in one process
<i>DPI & F</i>	The Department of Primary Industries and Fisheries, Queensland
<i>GRDC</i>	Grain Research and Development Corporation
<i>OH & S</i>	Occupational Health and Safety
<i>Line Trimmer</i>	Gardening tool used to cut edges of grass
<i>De-Huller</i>	Device used to remove the hulls of grains, mainly used in the rice industry
<i>KEW</i>	Kingaroy Engineering Works, a company that builds small research harvesters

Chapter 1

Introduction

This research and design project was commissioned on behalf of the Department of Primary Industries and Fisheries (DPI& F) by Biosystems Engineering. DPI& F has many research areas, this project is aimed at increasing efficiency in the research of 'black point' in wheat and barley. The current location of the hill trial plots for this project include Bundaberg, Toowoomba and Warwick. Biosystems Engineering is a local agricultural machinery design consultancy firm that has over the years built a working relationship with the DPI& F in assisting them with designs of their research equipment.

1.1 The Australian Wheat Industry

1.1.1 Wheat and Barley Production in Australia

Throughout the history of agriculture in Australia the main wheat grain grown is the white grain wheat. This grain is used in the milling for flour when the highest quality is reached. This flour is used in the baking industry for breads and now some varieties are being used in the production of pasta. Similarly in barley, the barley that has been grown in Australia is the barley that is ideal for malting. The highest quality barley is used in the malting process which in turn is used in the brewing of beer and other

drinks. When the grains of wheat and barley don't make the highest quality grade for, whatever reason, the grain is down-graded to a lower quality. The lowest quality is feed quality; this is when the grain is used in intensive meat production.

Statistics for the 2003 / 2004 season gave production numbers of around 26 million tones of wheat and up to 10 million tones for barley. This equates to around \$8 billion worth of produce in wheat and a value in the same order of magnitude for the barley, [Australian Bureau of Statistics, 2004]. In Australia present estimates are that consumption of wheat is around 5.5 million tones. Once this figure is met the surplus is exported overseas. In the 2001/2002 season, Australia accounted for 18% of world trade in wheat [Australian Bureau of Statistics, 2004].

1.2 Research of Black Point

1.2.1 Cost of Black Point to the Grain Industry

Black point is a disease that causes discolouration in the germ end of grain. Research from the DPI& F in Toowoomba Queensland, has discovered that "Black point is more likely to be an oxidized phenol resulting from the biochemical disruption of the ripening process brought about by stressful conditions. Peroxidase enzymes are responsible for browning in most damaged or stressed plant tissues and these enzymes have been found to be concentrated in the grain tissue that becomes discolored with black point" [Williamson & Michalowitz, 2003]. Previous research concluded that black point was a result of a fungus in the kernel that had been initiated by a rain fall event at an inopportune time of the kernel development. Due to the nature of the research and the possibility of climatic variations in the test, continued research into different varieties and climatic conditions needs to be continued.

In wheat and barley it causes the grains to be down-graded from a possible premium quality to feed quality. The discolouration is not desirable in the flour industry as it causes the flour to be an off white colour. Also in the malting industry the presence of black point causes the malting to give a colour that is not desirable to the consumer.

In Australia last year it was estimated that black point cost the wheat industry some \$50 million worth of down grades [Williamson & Michalowitz, 2003]. For barley the down grade can be as much as \$50 per tone of affected grain. This is a significant cost considering that this down grade can be as much as a quarter of the actual price received if the grain received is of premium grade. Due to these economic reasons it is desirable to have varieties of wheat and barley that are resistant to such a disease. This is the reason for the research project which is a joint project between GRDC (Grain, Research and Development Corporation) and the DPI& F (Department of Primary Industries and Fisheries).

1.2.2 Difficulties of Current Harvesting Process

The harvesting of the hill trial plots of wheat and barley is currently undertaken by manual labor. This harvesting process is very inefficient and has great potential for mechanization to increase the efficiency of this process. From each trial a seed sample is obtained. This sample is analyzed and forms the basis for the research. Occupational Health and Safety (OH&S) is one of the reasons why this project was commissioned, these include repetitive stress of bending, use of a sharp open bladed sickle, exposure to dust during thrashing, use of a thrasher and the mechanical parts of the thrasher and extended exposure of ultra violet radiation to bodily skin.

The task of designing a prototype to complete the whole harvesting process of removing the grains from the heads of the plants in the trial plot, cleaning the sample removed from the plant, and bagging the final sample into a package suitable for the DPI& F to use in their analysis process, makes up the bulk of this research project.

1.2.3 Set up of plots

The DPI& F has trial wheat and barley plots in several locations throughout Southern Queensland. These locations include Toowoomba, Warwick and Bundaberg. These sites vary in location but not in the geometry of the trials.

Wheat

The wheat plots are replicas of the broad acre version of farming, the plots are planted in rows like what would happen in the field. The plots are planted at the same density as what the average crop would be planted at. The plots are 0.5 metres long then a 0.5 metre gap then the next plot. The width between each row is also 0.5 metre. Last year there was a total of 4440 plots, 3000 in Toowoomba and the remaining 1440 in Bundaberg. See figure 1.1 and 1.2 for the set up of the plots.



Figure 1.1: Picture of a hill plot trial, early stage of growth.



Figure 1.2: Picture of a hill plot trial, late stage of growth

Barley

The barley plots are not like what would happen in a broad acre field. To reduce contamination at planting the DPI& F has opted for a very different planting method. The DPI& F has observed that contamination occurs due to the handling of many small amounts of loose seeds. To reduce this they now plant the barley as whole heads. Each plot is made up of one barley head being planted under ground. This reduces the number of loose seeds present at planting hence reducing the contamination at this early stage in the trials. The pictures below figure 1.3 and 1.4 are picture of the planting style the DPI& F has adopted. Figure 1.4 is a picture showing the effort needed to gather the heads together so they can be harvested.



Figure 1.3: Picture of a hill plot trial for barley, late stage of growth



Figure 1.4: Picture of a hill plot trial for barley, Gathering the plot together.

Harvesting

At present all the DPI& F trial plots are harvested using manual labor with minimal mechanization. The process is labor intensive and has high risk of contamination and large OH&S risks. The process starts in the field with personnel cutting the stalks of each plot with sharp sickles and separately bagging each trial. Each bag then needs to be labelled. The bags are then transported to the large stationary thrasher, which is usually located in Toowoomba which can be several hundred kilometers from the other plot sites. This thrasher has been taken to the field on occasions to reduce transport of bulk crop residues. Each bag is then thrashed and the seed is packaged. The thrasher needs to be cleaned between each trial to avoid cross contamination. If the thrasher is set up properly the sample does not need any further cleaning before analysis can take place, but if the sample has impurities due to a poor thrash, further cleaning needs to be done before the sample can be analyzed. Currently costs for harvesting these wheat

plots was estimated to be \$ 5700 and the thrashing of the wheat was approximately \$ 7500. This estimate was based on the time taken to harvest the plots and only includes the labor cost.

Contamination

Contamination can occur at several different stages in the harvesting process. Firstly the original gathering and cutting of the stalks could accidentally bring in heads of grain from adjoining plots. Then the bags can be mixed up when labelling hence the wrong plots will be thrashed into the wrong packages. When thrashing is taking place the thrasher might not be completely clean between trials hence contamination through the thrasher could occur. Due to these possibilities great care must be taken throughout the whole process to ensure no contamination takes place. If care is not taken, the whole year's effort may be wasted, and the trials may have to wait for next season, causing significant delay in the progress of the research.

Occupational Health and Safety in the harvesting process

Some of the OH&S issues include: repetitive bending stresses to cut stems, use of a sharp open bladed sickle, exposure to sunlight due to excessive time spent collecting and thrashing trials during summer months, use of a stationary thrasher and the need to be close to moving mechanical parts, exposure to dust particles in the air during the thrashing process.

1.3 Methodology

The research of this project consists of several steps. Firstly research must be conducted to ensure that knowledge of the latest research in harvesting technology as well as the current industry practices are known so that a mixture of new and current ideas can be used in the design phase of this project. Once the concepts are determined for the mechanism of the system, virtual models or virtual prototypes are built so that the

system can be constructed without spending much money or time in building up the actual prototypes. After the initial stage is completed, further prototyping is completed using components and materials that are readily available. These prototypes are used to test the concept and show that the system will work before any large amounts of resources are used in developing a working system.

Once the concepts are tested and are known to work, the full prototype will be built. Once the full prototype is built final testing and evaluation of the system can take place. This final testing will ensure that the system works correctly. The next step is to optimize the prototype and build a system that can be used in the field.

Chapter 2

Previous Research

2.1 Mechanical Properties of Wheat and Wheat Residues

When dealing with plant material it must be noted that, not all material that is grown on plants is uniform. This is due to the plants not manufacturing the plant material to any standard or set format, but are subjected to a range of environmental effects that change how the plant grows and produced foliage and fruit or grain.

The main mechanical properties that concern the design of the harvester are the properties that will aid in designing the separation section of the system. This system will use the differences in mechanical properties to sort the different material, discarding the unwanted and storing the grain. Whatever system is designed, there will be some distinct property that will distinguish the grain from the other plant material. Some of these properties are bulk density, size, and aerodynamic properties including terminal velocity.

Research has been carried out to determine the factors mentioned above, many books state values for these properties but most books are different and it is difficult to determine which reference is more correct. Since dealing with such a variable substance it may be easier to assume that the properties given are averages and that the actual crop will vary slightly. This is the reason that all modern combines have adjustments

for fan speed, drum rotation speed and sieve size. Being able to adjust these settings the operator has the ability to harvest varying crops and conditions from year to year. Below in table 2.1 is some of the mechanical properties for both wheat and barley and their associated plant material.

Table 2.1: Mechanical Properties of Grain and Plant Material

[Mohsenin, 1986,] (pp 251, 642, 643.)

Material	Bulk Density kg/m^3	Terminal Velocity ms^{-1}
Wheat	600	10
Barley	400	7.5
Wheat Chaff		1.3
Wheat Heads		2.3
25mm of Straw		4.3
75mm of Straw		3

2.2 Harvesting Methods

To be able to effectively design a harvesting system, an understanding of current harvesting and previous harvesting methods are critical to be able to utilize previous development of the harvesting system. As part of this research project, analysis of current working machines was undertaken. The following chapter is the analysis taken from literature on the modern combine machine.

The modern combine harvester can be broken down into 4 sections in which different processes take place. This analysis has been broken into these four sections. The first section is the removal of grain from the stalk. The second section is the conveyance of material to the thrasher. The third section is the thrashing. The final section is the separation of the grain from the husks and the remaining plant material. See Figure 2.1 for a schematic view of a combine harvester broken down into these 4 groups.

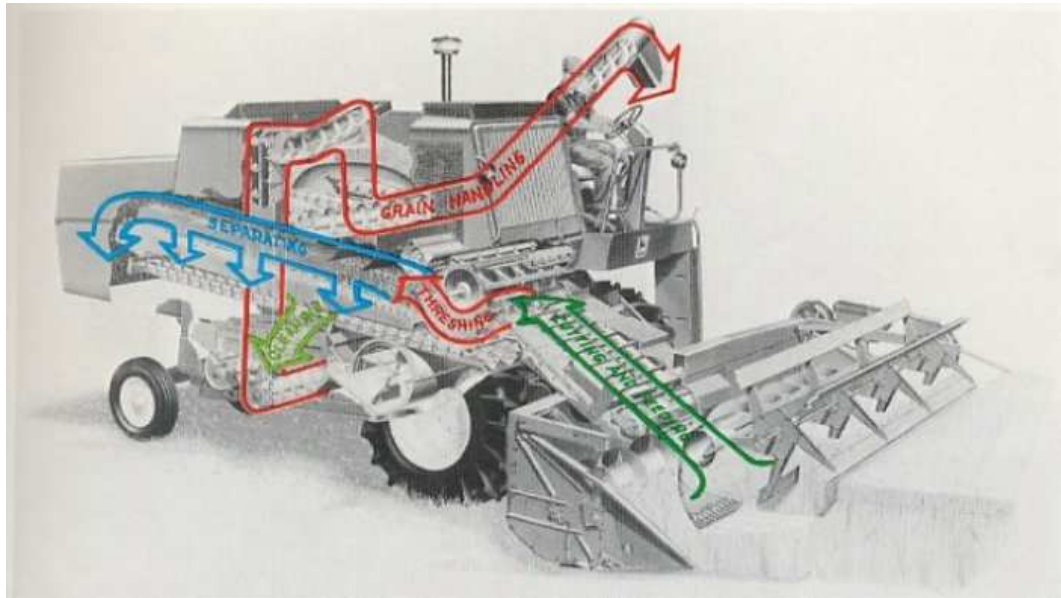

Figure 2.1: Schematic of an early John Deere Combine
 ([Griffin, 1973,] pp 51,)

The first section is the removal of the grain from the stalks. The heads of the plant, where the grain is located, are removed from the plant in some mechanical process. This mechanical process has developed over the years and now generally consists of a cutting or shearing type action of the stalks just below the heads of grain or a pulling or stripping type action . These heads are then ready for the next process.

The second section is the conveyance of the previously removed plant material to the next sub system where the grain is thrashed from the protective part of the plant, commonly known as the husks. This conveyance system starts directly behind the cutting mechanism and carries the product all the way to the thrashing sub-system.

The thrashing sub-system is the third system. In this system the grain is completely separated from all of the plant material. This process generally involves accelerating the product at speeds that cause the grain to shear away from the protective plant material.

Lastly the final section is the cleaning system. This system takes the material coming from the thrasher and sorts the grain from the remaining plant material. This section

in modern combines consists of a sieve and a stream of air blowing through the sieve.

Throughout the following analysis, devices used to harvest grains other than wheat or barley can also be found. This is due to the possible adaptation of these devices into this particular design. Due to this possibility, an analysis must be completed to understand the workings and feasibility of the device. These devices include: huskers or de-hullers for rice, pneumatic aspirators and concepts seen in previous designs for small plot harvesters.

In section 2.3 of this chapter is an analysis of existing small plot harvesters.

2.2.1 Grain removal from plants

Cutter Bar Platform

The cutter bar platform is found at the front of combine harvesters. It contains a reel, a reciprocating sickle and an auger. The reel holds the grain heads against the cutting bar to ensure that the grain is successfully cut from the plant and makes sure the heads fall onto the platform where the gathering takes place. The reel is like a paddle wheel that rotates in the same angular direction as the direction of travel. For lighter grains the reel is sometimes replaced by an air front that simply uses air to push the grain onto the cutter bar. The cutter bar either shears or cuts off the grain heads from the plant. It is simply an oscillating knife that runs between stationary fingers or guards on the cutting platform. The stationary guards act as the second edge for the knife. The knife is reciprocating along this platform between the guards, cutting the plants that are being pushed against the platform by the reel and the forward motion of the combine.

See figure 2.2, below for the configuration of this cutter bar platform on a small plot harvester.



Figure 2.2: Schematic of the Front Cutter Bar of a KEW Plot Harvester

Stripper front

The stripper front is an alternative front to the cutter bar platform. The stripper front only takes the heads of grain from the plant and leaves the rest of the plant residue behind. This improves efficiencies of the thrashing and cleaning as there are no stalks in the trash sample simply the material associated with the heads of grain. Extra losses are incurred by the stripper front compared to the cutter bar due to the stripping action of the front bar. There are several different designs for strippers, the main component is a comb like device that strips the heads of grain from the plant. The gathering process is the same as that of the cutter bar. The main designs for the stripper are a stationary stripper plate and a rotating stripper reel.

The stationary design is where the forward motion of the combine is used to pull the heads through the stripping plate. The forward motion pulls the stalks through the small opening in the stripper plate but does not allow the heads to be pulled through. Therefore the heads are broken from the stalks just below the head.

The rotating stripper reel or “The Silsoe stripper uses the transverse rotor principle in which stripping of the crop takes place along the whole length of the rotor arranged transversely to the direction of travel. It consists of flexible arrow head stripping

elements mounted on a horizontal rotor of 540 mm diameter and rotating at 600-800 rev/min resulting in a peripheral speed of 17-22.7 m/s.”

[Tado, Wacker, Kutzbach & Suministrado, 1998,] Figure 2.3 is a figure showing the arrow head stripping element.

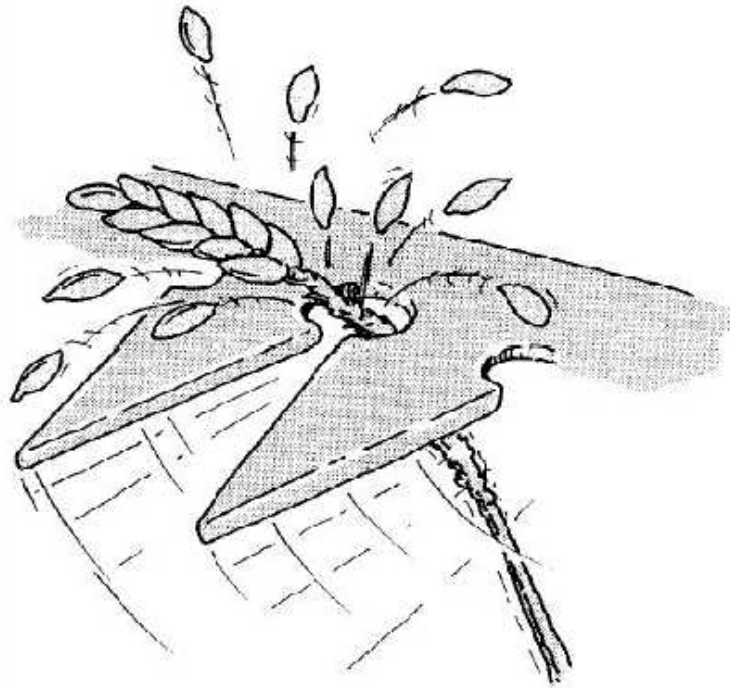

Figure 2.3: Schematic of the stripper elements

([Tado, Wacker, Kutzbach & Suministrado, 1998,] pp 107,)

Circular Disk

The circular disk or a disk similar to a circular saw has been used in designs of a single row harvester. In the section of existing systems, a patent can be seen of one such design. This design utilizes the circular disk to cut the stalks of the crop just inside the housing of the hand piece. The heads of grain are then free from the plant and are transported to the thrashing unit.

2.2.2 Conveyance systems to the thrasher

Platform Gatherer

There are two main types of gathers on the platform. The first is a helix that is built into the platform; This helix rotates in a direction so that the harvested material is swept into the centre of the front where it gets fed into the thrashing unit. This helix operates like a semi-enclosed auger with the bottom half of the helix sitting in the platform that is molded to hold the rotating helix. The second type is a belt type; the belt takes the place of the helix and sits just behind the cutting bar. The belt moves the harvested material to the gathering place to be fed into the thrasher.

Once the grain is at the gathering place the main mode of transport to the thrasher is by a chain elevator. This chain rotates and pulls the grain and material from the gathering place up the feed housing to the thrashing concave. Sometimes there is a paddle to ensure continuous flow of material to the thrashing unit between the elevator and the thrashing concave. See figure 2.4 for a view of the chain elevator.

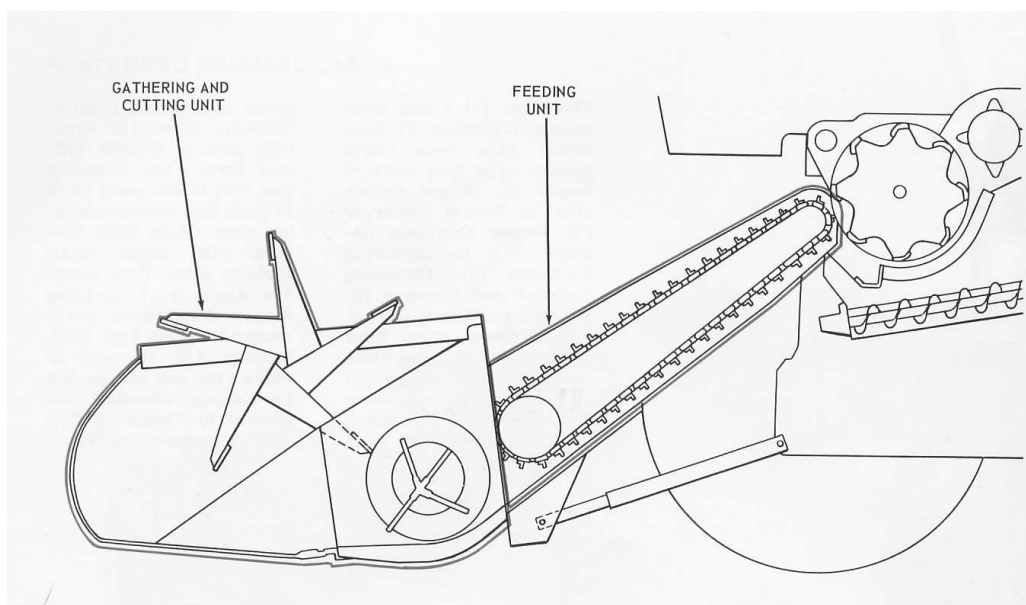

Figure 2.4: Schematic of a feed unit([Griffin, 1973,] pp 24,)

Pneumatic conveyor

The final type of conveyor is a pneumatic conveyor. The pneumatic conveyor uses air to suck or push the material up the housing to the thrashing unit. The air is provided by a blower, the speed of the air is adjusted pending on the crop type and speed of the harvesting unit. There is currently no design that utilizes the pneumatic conveying of the cut material but the design has the ability to be adapted to a system if a mechanical transport system can't be used. Pneumatic conveying is used extensively in the cotton industry as part of the cotton harvesting and cotton processing systems.

2.2.3 Thrashing systems

Rasp and Bar

The rasp and bar system consists of two main parts, the thrashing drum and the concave. The Thrashing drum is a series of bars mounted around the circumference of a set of hubs. The set of hubs rotates perpendicular to the direction of travel. The concave is a series of parallel steel bars held together by curved sidebars and rods. The curved sidebars make an angle around ninety degrees and the concave sits under and slightly to the rear of the drum. The curve of the concave is matched to the drum as the thrashing of the grain happens between the drum and the concave.

The material is accelerated by the rotating drum, shattering it against the concave and separating the grain from the crop material. Figure 2.5 is a concept thrashing system of the New Holland CX series combine. This thrashing system has two drums and concaves.



Figure 2.5: Concept of the thrashing system for a CX Series New Holland ([Case New Holland Australia Web Site, 2005])

Spike and Tooth

The spike and tooth thrasher is similar to the design of the rasp and bar in that it has the same main components in the drum and concave. The drum is made up by a number of steel teeth attached to steel bars that are mounted around the edge of a set of hubs. The concave is similar to the rasp and bar except there are teeth attached to the concave instead of bars. The teeth are arranged so that there is clearance between the teeth on the rotating drum and the stationary concave teeth.

The teeth tearing and shredding the material in this case cause the thrashing mechanism. This causes the grain to be separated from the crop material. This type of thrasher is more aggressive than other designs and has the capability of handling higher volumes of crop material.

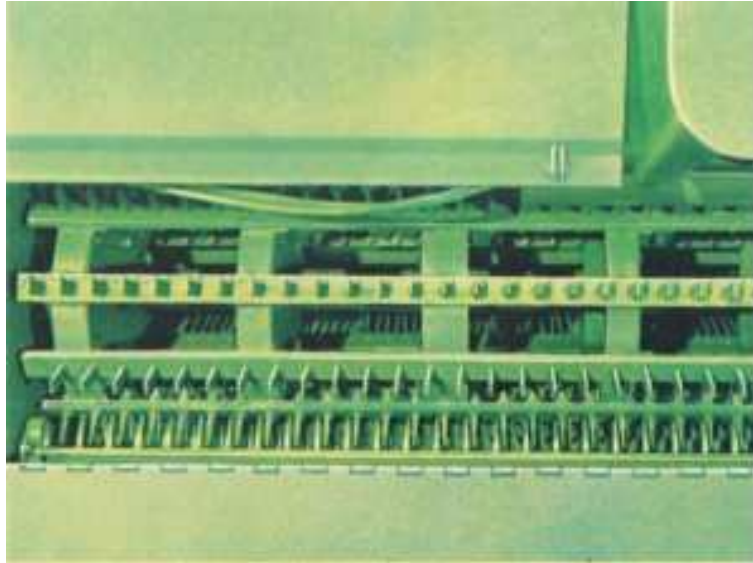

Figure 2.6: Concept of the spike and tooth thrashing system
([Griffin, 1973,] pp 31,)

Angle bar Cylinder and Concave or Axial Cylinder design

The angle bar thrasher is the same design as the previous two; the only difference is the design of the drum. In this case the drum is made by a series of angle bars mounted around the circumference of a set of hubs. The angle bars are mounted in such a way that they make a helix. In this case both bars and concave have rubber faces. The drum is set up so it runs parallel with the direction of travel.

This thrasher flails the grain rather than rubbing the grain apart. This type of thrashing system is a lot gentler and is commonly used for fragile crops. This design is also more powerful and is becoming the more popular design as it has a higher capacity. See the figure 2.7 for a picture of a thrashing drum from an axial thrashing system made by Case International. Note that only the drum is shown, the concave is not shown for clarity. The concave would sit below the drum similar to the previous thrashing systems.

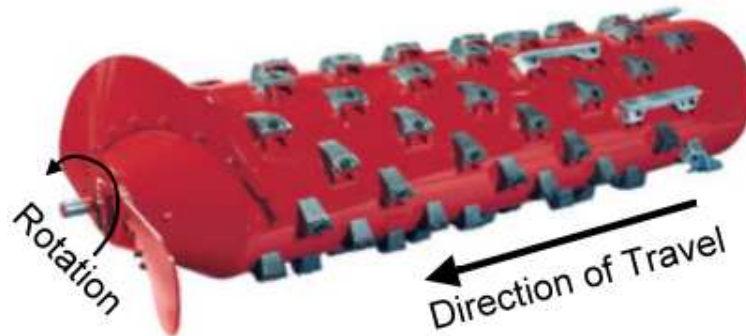

Figure 2.7: Diagram of an Axial Thrasher
([Case New Holland Australia Web Site, 2005])

Rubber Roller, Rice Husker

The rubber roller type of thrasher is used for de-hulling rice. The rice is gravity fed between two rubber rollers. These rollers are touching and turning in different direction at different speeds. The pressure that is regulated between the two rollers, is what causes the de-hulling effect. See figure 2.8.

In this case the rice is separated due to the difference in speeds between the two rollers. As the rice is pulled through the rollers one side is subjected to a greater increase in speed causing a differential force between the two sides of the rice hull. This difference in force shears the hull and the rice is freed from the hulls.

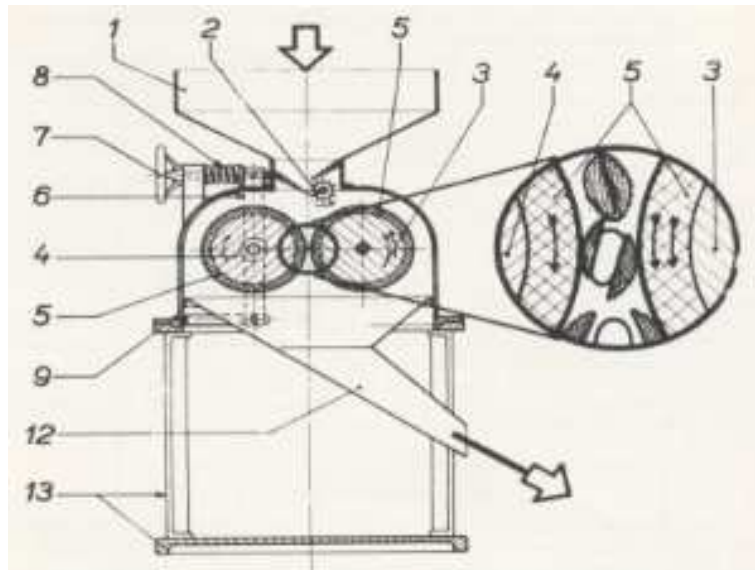

Figure 2.8: Schematic of the Rubber Roller Dehuller
 ([Houston D.F., 1972] pp 192,)

Belt Thrasher

A belt thrasher has many uses in a variety of applications. The principle has been used to de-hull hazelnuts and has also been used in small trial thrashers. The principle is the same as the rollers; there are two belts moving in opposite direction and at different speeds. The grain or nuts are placed between these belts and slowly moved in the direction of the greater speed of the belts.

The separation mechanism for a belt thrasher is the same as the rubber roller, the differential force between the belts causes the hulls and husks to separate from the grains.

Disk Sheller

The disk sheller consists of two disks both with emery facing. The top disk is held horizontal and stationary and the second disk is rotated about a vertical axis. The grain is fed through an opening in the top of the stationary disk and is forced between the two disks by the centrifugal force. The distance and pressure holding the two-disks

together regulate the friction between the two disks and the grain.

Thrashing occurs due to the friction of the two disks and the differential force between the stationary and moving disks. This method is older than the rubber roller rice husker and is mainly used for rice dehulling.

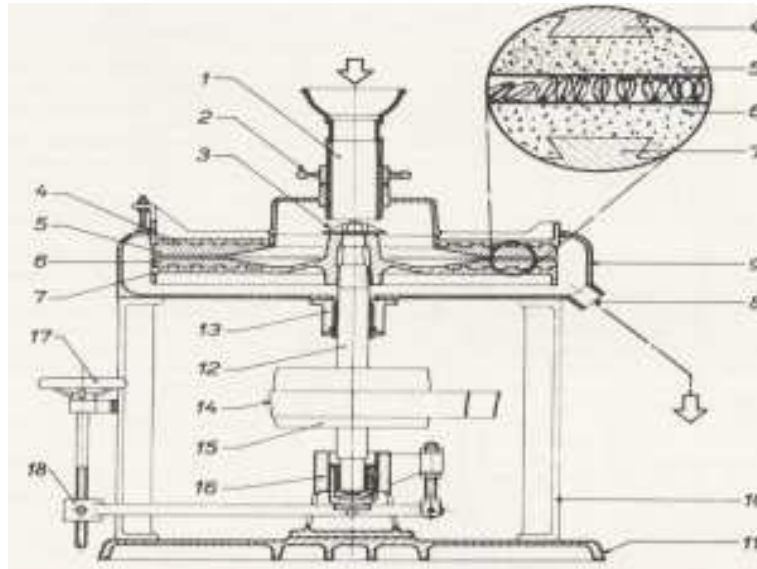

Figure 2.9: Schematic of the Circular Disk Dehuller

([Houston D.F., 1972] pp 193,)

2.2.4 Cleaning or Separation of Grains from Plant material

Sieve, Blower and Trash Walkers

The three components to this system are the grain sieve, the blower and the trash walkers. The sieves and trash walkers move in a reciprocation motion and shake the grain through the sieve and walk the trash to the back of the sieves. The blower aids the process by insuring that the light small trash does not fall through the sieve with the grain and keeps the light material suspended over the heavier trash to exit the process with the heavy trash.

The separation occurs due to the size of the holes in the sieves. Only the grain can fall through the sieve.

The combination of the motion of the trash walkers, the presence of the blower and the mechanical properties compared to the grain separates the grain and trash. On most conventional sieves, adjustment is provided so that grain of different sizes can pass through the one sieve. See figure 2.10 for a schematic of the trash walker and sieves used in John Deere Combines.



Figure 2.10: Diagram of the John Deere Cleaning System
([John Deere Australia Web Site, 2005,])

Aspirators

There are many different designs for aspirators that work for many different applications. The main components of the system are a variable flow of air and an air column and separation compartments.

The cleaning is achieved by the difference in bulk densities of the grain compared to the rest of the crop material. The airflow is not enough to keep the grain entrained in the air flow, therefore the grain falls under gravity while the crop residue is still entrained in the air flow and is removed from the grain sample. This makes the grain fall and the crop material float. Collection of both the grain and separated material occurs because of the designed compartments.

Pneumatic Separator/ Cyclone

The cyclone design is the same principal as the aspirators, the grain and plant material is entrained in an air stream. “The particle-laden gas is accelerated through a spiral

motion, which imparts a centrifugal force to the particles. The particles are hurled out of the spinning gas and impact on the cylinder wall of the cyclone. They then slide to the bottom of the cone. Here they are removed through an airtight valving system.” [Davis & Cornwell, 1998,]

This type of separation is quite compact and can be quite effective if there is a large difference between the bulk densities of the grain and plant material. Usually cyclone separators are only used for separation of particles between the size of 10 and 100 microns.

Vibration Table

Vibration is used in many industries that involve moving distinct particles at a constant rate. Throughout the mining and food processing industries vibration feeders are slowly becoming common place. Vibration feeders are used as they provide a way for a wide section of material to be evenly fed into a processing machine. The jumping action provided by the vibration insures a constant feed of the material across the entire table. Vibration is also used to move particles vertically in a small confined area. In the food processing industry towers of spiral flights are oscillated in a vertical and rotational manner providing the particles with motion around the flights, hence creating an upward movement of particles.

There is a possibility that this technology may have the ability to move particles up an inclined table. The speed of the uphill movement will be dependent on the actual properties of the material. If the dense particles were to move faster up the incline then separation of the wheat from the husks would be possible. Further investigation is needed to test the efficiency of such a system.

Sorting Chamber Separator

A sorting chamber is a relatively unseen concept in industry, per se. In reality a cyclone separator is simply a circular sorting chamber. It is proposed that if such a chamber could be designed to allow the air stream carrying the wheat and husks to

slow in velocity then according to the material properties the particles should drop from the air-stream at different times according to their bulk densities. Such a system is possible to design on paper. Considerations of the inertia of the individual particles and momentum of the fluid is neglected as mostly these systems are dealing with small particles and low velocity fluids. This represents a problem when designing a system to separate wheat which has a considerable mass compared to the drag applied by the slowing air stream and hence to design a working system inertia and momentum need to be accounted for.

2.3 Existing Systems

Since harvesting grain is not a new concept there are a large number of existing systems already designed and working. The following sections describe the existing systems that have been viewed by the author. The first three systems are systems designed to harvest small research plots, similar to the hill plots in properties but the scale of the hill plots are still much smaller than the plots that the following systems harvest. This means that the following systems can't be used directly as they are too large. However, looking at these systems is beneficial to see how other research harvesters overcome the problems with designing a research harvester.

2.3.1 Single Row or Plant, Combine Harvesting Machine

This system was designed in the U.S. for harvesting single row trial plots. This system uses a rotating disk as the severing mechanism inside a housing, which then draws the entire cut crop into a thrasher. The thrasher is just an impeller that also acts as the vacuum and displacement fan for sucking and conveying the cut and thrashed material.

The above mechanisms are all incorporated into a hand piece that is driven by a single or two electric motors. The cut and thrashed grain is then moved under pneumatic power to the separating unit. The thrashed grain is then separated from the husks by a cyclone aspirator, which is mounted on a back pack and the grain is held at the bottom of the cone by a valve easily opened for collection of the seed.

The design also incorporated a wheel system so that the separator or both the separator and the hand piece could be mounted on the wheel frame. A portable generator in the field where the harvesting takes place generates the power for the electric motors. An extension lead is run to the harvester from the generator to provide the power to the harvester. See Figure 2.11 for the design and layout of the system.

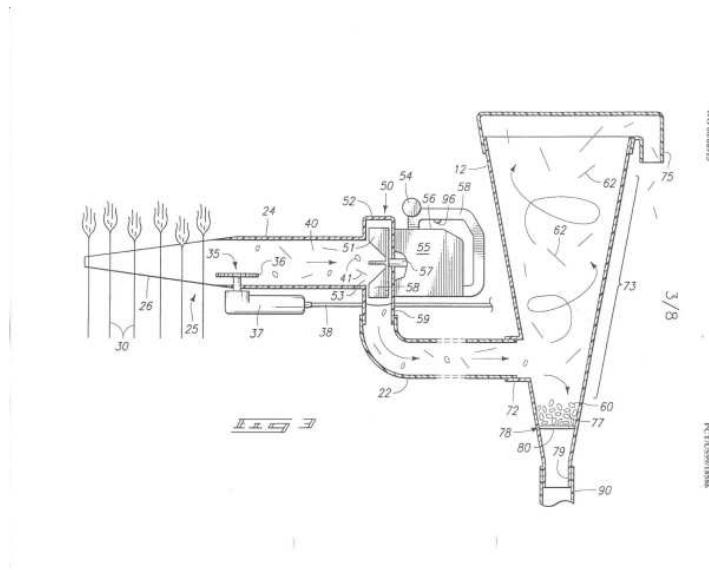

Figure 2.11: Diagram of the Single Row Harvester
([Calvin & Davis 2000])

It is suspected that this system does not perform well. The cyclone unit may not be able to separate the grain head from the trash effectively. Also the thrashing of the grain, which is carried out by the fan may not be complete as well as possibly damaging the seed. Since the system to be designed is for research purposes, the ineffective separation and the possible loss at the thrashing point means that a system like the single row harvester will be ineffective.

2.3.2 Kingaroy Engineering Works Plot Harvesters

Designed and built by Kingaroy Engineering Works (KEW), these self-propelled plot harvesters are suited for plots of two rows. These plot harvesters are like a conventional combine harvester just smaller. The main components that are seen in a large

conventional combine harvester are also in these plot harvesters. There is a cutting bar, threshing drum and a sieve and trash walker cleaning system. The fronts on these harvesters are interchangeable depending of the crop and which front is better suited for the crop.

The storage bins are capable of holding 250 kg of material and can unload via an auger into a truck or storage bin. The machines can be fitted with real time sensors for moisture, yield and total weight of each plot. See figure (2.2 and 2.12).

It is estimated that the price tag for this system is around \$150 000, which is too expensive for such small plots. Also these combines are not self cleaning as it is difficult to clean the trash walkers to prevent cross contamination between different trials.



Figure 2.12: Picture of the Rear View of a KEW Plot Harvester

2.3.3 KEW Walk-Behind Thrashers

This self-propelled walk behind harvester is designed for harvesting a single row of crop. It utilizes a reciprocating knife to cut the crop, a rasp and bar drum to thresh the heads and a set of sieves and trash walkers as the cleaning mechanism. The clean grain is stored in removable hessian bags, which are replaced once full.

The KEW walk behind harvester uses a small four stroke engine around the 10 horse power size to drive the mechanism. The overall dimensions are the same size as a push

mower except the height of the harvester is much taller, almost the same height as the top of the handles.

2.3.4 Large Scale Combine Harvesters

Large-scale combine harvesters are used throughout the world, there are several different companies that make them and all are slightly different in their design. The main components of the system can be broken down into four groups; removal of grain from the crop, conveyance of material to the thrasher, thrashing system and cleaning mechanism. These groups have been discussed with possible designs that are used in each group.

Due to the size of the systems the large scale combine harvesters will not be analyzed further as the sections above have discussed the many possible designs.

Chapter 3

Aims of the Portable Harvesting System

3.1 Purpose of Hill Trial Plots

To analyze the aims of the portable harvester we must first understand why the plots are being researched and the aims of each plot, then the aims of the hand held harvester will be evident.

Black point is a problem each year in Australia and some farmers incur significant downgrading and losses due to black point. Recent research has challenged traditional ideas on the nature of the problem and identified valuable sources of resistance. Highly susceptible wheat and barley lines need to be screened from breeding programs but present methods are time consuming and expensive. Collaborative research, funded by GRDC (Grain, Research and Development Corporation), involving the Leslie Research Centre, DPI& F and the University of Southern Queensland has found the first molecular markers which, when verified and put to use, will speed up this process and enable breeders to set minimum standards of black point resistance for future wheat and barley variety releases.

“Black point was previously thought to be the result of saprophytic fungal infec-

tion. However, most healthy grain is infested with fungi and many recent studies have concluded that a fungal association is unlikely. Black point is more likely to be an oxidized phenol resulting from the biochemical disruption of the ripening process brought about by stressful conditions. Peroxidase enzymes are responsible for browning in most damaged or stressed plant tissue and these enzymes have been found to be concentrated in the grain tissue that becomes discolored with black point. The precise nature and timing of the environmental stresses that induce black point symptoms are not fully understood, however, yield, humidity and temperature are likely to be involved. Rainfall between anthesis (flowering) and harvest is not essential for symptoms to occur in highly susceptible wheat varieties that ripen under humid conditions.” [Williamson & Michalowicz, 2003]

3.2 Scope of the Hand Held Harvesting System

One of the biggest limitations of the research is the cost of maintaining and processing so many hill trial plots. In the 2004 season 4440 hill plots were planted for wheat black point research. The cost of harvesting the plots with the current methods are large. The process is labor intensive and also requires a large amount of bulk material transport and OH&S risks.

The aim of the project is to develop a system to streamline the current harvesting process. This system must;

- Separate grain from plant material leaving a clean grain sample. The constraint for this system is that the final sample must be at the standard as that which they currently receive from the current harvesting process.
- Place the extracted sample into a processing envelope. This part simply ensures the user that the sample is obtained and at a point where the post harvesting analysis can begin.
- Avoid cross contamination of plots. In any research the aim is to receive good quality data. If contamination occurs the data for that plot is no longer valid

and cannot be used for further research. To do this, the machine must be easy to clean or self cleaning, after each operation.

- Self cleaning between plots. This attribute of the harvester is a must, as without the self cleaning mechanism the contamination of plots can be occurring within the harvester.
- Minimize OH& S risks. This project will be designed to reduce the possible risk of injury to the user and any persons in the vicinity of the harvester.
- Insure ergonomic design to allow user extended periods of operation
- Low cost

3.3 Secondary Design Requirements

Secondary design considerations will ensure that the project has covered all possible design considerations. Some of these considerations are not vital to the project but will ensure that the final product is viable and meets exactly what the client is seeking to purchase. The following points are included as guides to assess each prototype, if the design fulfills all the above design constraints and adheres to the secondary design constraints listed below the prototype will be seen as a success and further development can commence from there.

1. The new harvesting system must be an improvement on the current system in terms of efficiency of the separation.
2. The final grain sample obtained from the new system must be at the standard of the previous system.
3. Due to the research nature of the harvested crop, the new design must look to minimize chances of losing the research data, or damaging the data in such a way that it is no longer good for the intended purpose of the research.

Since this harvesting system is part of a larger research project the aims of this project must align with the aims of the larger research project. The larger research project is

to develop black point resistant varieties in wheat and barley. In designing and building this project, the larger research project will be more cost effective and will reduce the time spent in the field harvesting the trials.

3.4 Design Methodology

3.4.1 Introduction

In the design process, a solid modelling program was used. The program Solidworks, is a mechanical type modelling program that has many features that aids in the designing and building of mechanical components and metal fabrication. In Solidworks a parts library is constructed and then an assembly is created, using relationships between parts to hold the assembly together.

After each concept was designed on the computer the virtual prototype was build and initial tests were carried out to insure that the concept would work.

Each test was evaluated to some degree, some tests more formal than others. The tests were on the basis of the objectives of the project. Initially concepts needed to be tested so simple tests were carried out to insure that the prototype concept would effectively carry out the design requirements. Once the prototype were confirmed as working further design and more comprehensive tests were carried out.

3.4.2 Prototype Design

Initial Concepts

Due to the size of the research plots that are to be harvested, the size needed in a harvester is far smaller than any other commercially available harvester. This can restrict some harvesting principles that are used in modern combine harvesters. For example, due to weight restrictions and size, a standard thrashing drum and concave will be inappropriate for this system. The thrashing drum is the key part of the combine

harvester as it is the mechanism that separates the grain from the plant material. The properties of the thrasher that makes it thrash the grain can not be reduced in size and therefore makes it unable to be utilized in this system. There are more of these principle mechanisms that can not be used in this project, therefore unique designs and concepts need to be used.

Concepts used in this project come from a variety of places. Some concepts are original and other concepts are used in different fields and in this project we are trying to bring these concepts to wheat and barley harvesting. After discovering these concepts the theory is analyzed to see if the concept can be modified to suit this harvesting system.

Some of the concepts used in our initial designs can be seen in the following chapters.

Concepts to Models

Once a concept has been realized, the next step in the process is to understand the mathematics behind the concept. Once the mathematics is understood then the numbers can be altered pending on whether we need the concept to be enlarged or reduced in size.

Once some design numbers have been calculated a model of the design is created. This allows us to see on a computer screen if the concept will mechanically work and allows us to check dimensions and weights of the components that will be used to build the concept.

At this stage of the modelling some calculations made in the previous steps are checked on the screen. The numbers might then be altered slightly to allow ease of manufacture and to ensure that a prototype is possible to build.

Solid works is an extremely valuable tool at this stage of the design. Solid works allows us to use real life material and fabricate the model as it would in the work shop as if the actual prototype was being built. This ensures that the designs are possible to build and that the prototypes will come together the first time, this eliminates costly time being wasted trying to fabricate a design that has not been realized before.

3.4.3 Prototype Building

Prototype building is not usually an exact science. In this project it was aimed to make the prototypes work the first time to reduce the cost of this part of the design process. Due to the modelling program used it is however much easier to build a prototype the first time and get it to a working standard the first time it is built. Using this modelling program it was assured that each time we built a prototype it would fit together and achieve what it was suppose to achieve.

Since funding was not assured, cost saving was needed in the building section. Often the prototypes were built using offcuts to try and reduce the cost. The building stage was a process using materials that were readily available and easy to fabricate. The main materials used were mild steel, nylon and cardboard.

3.4.4 Prototype testing

Testing of the prototypes were aimed at being time efficient and cost effective. The tests carried out were simple and proved that the untested concepts would work.

Due to the timing of the growing season of wheat and barley compared to the time line of this project, full prototype testing will not be possible for this research paper. To test the system mature heads of grain are needed to verify that the full system is working.

Small tests will be carried out on individual components to ensure that the components are working. The only part of the system that can not be tested will be the conveyance system that links the components together.

3.4.5 Prototype Evaluation

Evaluating the prototype was based on the design specifications. Each prototype was testing a new concept, therefore each prototype needed to align itself with the design specifications in each case. The most important parameter is the cleanness of the grain

obtained.

3.4.6 Optimization

The optimization of each concept was the important part in developing the whole system. At this point, once the concept has been deemed as working, the design focus then begins to engineer a way to incorporate the concept into the whole system. The optimization section of this project is not optimizing a certain part but rather optimizing the concept to fit into a working system so that the integrity of the concept is kept but the system is made to work rather than the prototype.

In optimizing the prototypes, the focus is shifted off the actual part, to the whole design specifications,(weight,size and safety) in a bid to allow the new concept to be incorporated into the hand held harvesting system. At this point the prototypes will be analyzed against other existing systems to insure that the chosen design is up to a working standard.

Chapter 4

Possible Designs

4.1 Critical Elements of System

As described in the earlier research section, a harvesting system can be broken down into four main sections. The removal of grain from the plant, the thrashing of the grain from the protective plant material (husks), separation of the grain from the husks, and the conveyance system that connects the above processes together. In figure 2.1 a schematic of the four systems can be viewed, noting that author of the schematic has added a fifth and sixth section of cleaning and grain handling.

Throughout the design process the project has been broken down into three sections with the final section of the conveyance being incorporated into the other three sections. The following sections describe the design process and is separated out in these four sections to help in the understanding of this project.

Throughout the design process the aim was to optimize the space and resources required to do the job of a modern combine. This has lead to some creative ideas and has also lead to some of the sections being combined so that one part carried out two actions or process.

4.2 Removal of Grain From The Crop

4.2.1 Grass Trimmer

Cutting shears

Following the success of the convention combine harvester the first initial concept was to develop a system that cut the heads of the crop and then transported the material to the thrashing system. After research of gardening tools it was found that there existed a small hand held hedge trimmer with an interchanging front. The interchangeable front could be changed from the traditional style hedge trimmer to a more shearing like front. The figure 4.1 is a rendered picture from a solid model of the grass trimmer.

To incorporate this trimmer into the design, additional engineering would be required to thrash, separate and convey the product. The thrashing and the separating will be discussed in later sections. The conveyance system required needs to be light and is able to move large wheat and barley heads to the next process after the heads were sheared away from the plant by the grass trimmer.

Pneumatic conveying was the chosen method for the conveying of the cut material in this concept. This type was chosen as it is easily attached to the small grass trimmer and the effectiveness of the pneumatic system is far better than what could be obtained from a mechanical system.

Some other considerations in this possible design is the OH&S associated with the grass trimmer. Modifying the Ozito Grass trimmer into this system would mean that all the safety features that allow Ozito to sell this product are void. The safety of the operator is the first concern when designing as an engineer, therefore the safety of the operator needs to be taken into account during the design process.

To use this trimmer the operator would need to gather the heads of the plot together in one hand, hold the stems and then with their other hand run the trimmer through the stalks allowing the trimmer to shear the heads of the plant and be conveyed by the conveyance system. Since the operator has the extents of their body near the area

where the trimmer needs to cut, sufficient guards need to be in place to insure that the operator can not access the moving blades to injure them self.

Figure 4.1 below is an initial design of the possible conveyance system and safeguards attached to the Ozito trimmer.

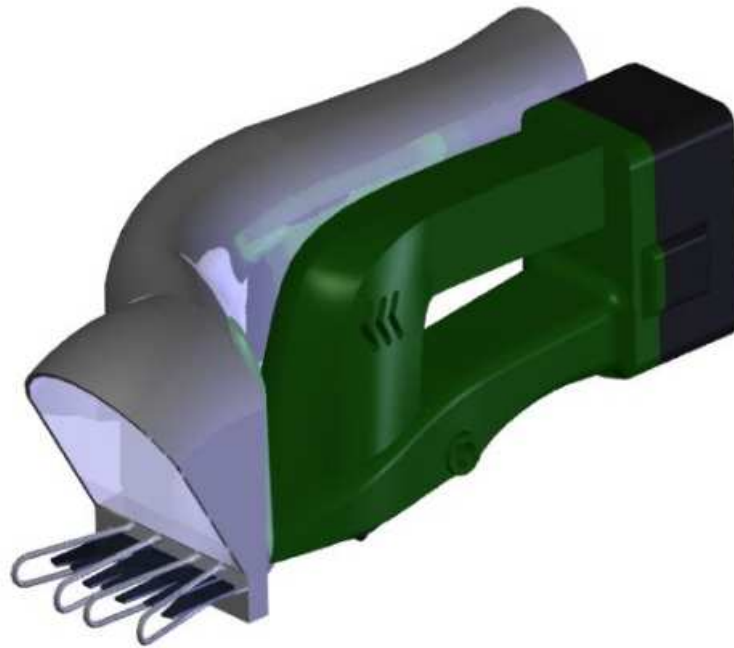

Figure 4.1: Diagram of an Ozito Hedge trimmer with safe guards

Advantages

- Tried and proven method for removing grain from the crop.
- Simple device available to be purchased from a hardware store.
- Easily adapted to the system using a pneumatic conveyor.
- Light and portable.

Disadvantages

- Pneumatic system needs to be large to carry full heads of wheat not just particles.
- The system needs a reliable thrasher to thrash the grain away from the plant material
- OH&S issues will need to be addressed due to the shearing action of the blades and the need for the operator to be near them.

4.2.2 Beater Front Principle

A second option for the removal of grain section is to develop a way to remove the grain without cutting the crop, similar to the stripper or reaper which was the early combine first developed in Australia when mechanization began moving through the farming sector. The principal idea is that if a force is applied to the underside of the kernel of wheat or barley the kernel will be dislodged leaving the stalk in tack. Research has developed this principle into a more working device as it increases the efficiency of the threshing system of the modern combine as there is less trash being taken in by the combine. The problem with this method is that it increases the front losses and so the engineering problem exists as to whether the increase in efficiency justifies the additional losses.

In this project the aim is to obtain a small sample of grain to analyze for statical analysis. This allows us to not worry so much about the losses but to try and increase the time and space of the hand held device. This is why this concept is a consideration when designing the harvesting system.

Taking this principle of applying a force to the bottom of the kernel to dislodge the grain is simply what this section is seeking to achieve. Since our specification allows us to come up with new ideas, the way in which the force is applied to the kernel became the focus of this section.

It was proposed that a series of line trimmer cord be positioned around an inner boss to create a version of a thrashing drum. The boss spins at a certain speed allowing the line trimmer cord to extend and move at a velocity around the inner boss. The force is then applied to the kernel when the head of the wheat or barley comes in contact with the line cord while it is in motion. The direction of the cord is the same as that of the stalks, implying that the stalks are never cut but simply the kernels are dislodged from the head.

Once the grain is dislodged the beater then needs a way to collect the material from the plant and separate the grain from the husk and protective parts of the plant. The proposal is again to use a pneumatic system to collect and move the product to a

separation system.

Figure 4.2 is a picture of the initial prototype built to test the principle described above.



Figure 4.2: Initial Prototype of Beater Principle

Advantages

- Simple device easily designed and tested.
- Easily adapted to the system using a pneumatic conveyor.
- Light and portable if designed with the correct material.
- Eliminates the OH& S risks as there are no shearing blades.
- Eliminates the need for a thrasher as the grain is removed from the crop head while the crop is still standing.
- Self cleaning

Disadvantages

- May be unreliable and dependent on the crop conditions to be optimal.
- May not handle the seed softly and may cause damage to the seed.
- Since plastics will be used as parts, the wear life may not be acceptable.

4.3 Thrashing

This section looks at non-conventional ways in which thrashing can occur. This is due to size restrictions on scaling down modern combine thrashing systems. Although it is still possible to design a small trash walker and sieve system the possible solution will be outside the scope of this project. Therefore the trash walker and sieve system will not be looked at in this evaluation of the possible design chapter.

4.3.1 Belt Thrasher

The principle of a belt thrasher is the same as when grain is rubbed off the husks by rubbing the wheat head between a pair of hands. The principle is simple and it is also reviewed in the earlier chapter 2.

Currently laboratories use these thrashers as they are clean and efficient. The possibility of incorporating a belt thrasher into this system is high as there are already belt thrashing systems on the market, it would need the purchase of one device and the incorporation into the system. Once the thrasher was incorporated then some test would see exactly what the belt thrasher capabilities are.

Advantages

- Easily designed to be self cleaning between trial plots
- Easily adapted to the system using a pneumatic conveyor.
- Light and portable if designed with the correct material.

- Has the possibility to be quite efficient and gentle on the grain.

Disadvantages

- May be difficult to design as limited research has been completed
- Has the possibility of removing the husk layer around the barley, this is where black point is found in barley therefore for this project it would be undesirable.
- Requires a separate power source to drive mechanism

4.3.2 Line Trimmer Cord, Beater

As mentioned above the possible beater principle could be utilized as the removal from the plant but would also act as the thrashing system. This is an advantage as one simple device has the possibility to do two processes. The process mentioned above is the same for the removal of the grain as that in which it would be in the thrashing section.

4.3.3 Circular Rice De-Husker

This de-husker is primarily used in the rice industry, as a simple way of removing the husks from the rice. The process is quite simple. The disk sheller consists of two disks both with emery facing, the top disk is held horizontally and stationary and the second disk is rotated about a vertical axis. The grain is fed through an opening in the top of the stationary disk and is forced between the two disks by the centrifugal force. The distance and pressure holding the two-disks together regulates the friction between the two disks.

Thrashing occurs due to the friction of the two disks and the differential force between the stationary and moving disks. This method is older than the previous mentioned and is mainly used for rice de-hulling.

This process has the potential to be quite efficient but also can have it's problems in

setting up the machine to not mill the grain but to simply apply enough pressure to remove the protective layer of husks.

Advantages

- Can be designed to allow for adjustment in the thrashing settings.
- Easily adapted to the system using a pneumatic conveyor.
- Light and portable if designed with the correct material.
- Has the possibility to be quite efficient and gentle on the grain once set up and tuned correctly.

Disadvantages

- Existing designs mainly use stone as the disks, this may cause the weight to become far too great.
- Has the possibility of removing the husk layer around the barley, this is where black point is found in barley therefore for this project would be undesirable.
- Requires a separate power source to drive mechanism.

4.4 Separation

This section is the hardest section to come up with possible solutions, due to the fact that in industry there is really only one way to separate grain from husks which is using trash walkers, sieves and a blower. For this project it is desirable to come up with some other possible solutions to the separation problem as the traditional trash walkers and sieves may not be the best solution for this system.

4.4.1 Cyclone Aspirator

Through out the processing industry the Cyclone aspirator or cyclone separators are used extensively for separating small particulate out of an air stream. The cyclone separator uses centrifugal forces to move the particles to the outer radius of the separator while the air rotates on a smaller radius inside the particles. The air stream leaves the cyclone from the inside radius, therefore, extracting only clean air without the particles.

Cyclone separators are used on particles of size 10 to 100 micron in cut diameter. To apply this concept to the grain and husk situation since the particles are much larger than the 100 micron it needs to be determine whether it is possible to design such a system.

Advantages

- Large amount of existing research to base designs on.
- If designed correctly the separation is quite robust and reliable.
- Has the possibility to be quite efficient and gentle on the grain once set up and tuned correctly.
- Fits into the pneumatic system and dumps the grain and carries the trash and dust to a deposit area away from the operator.
- Self cleaning between plots.

Disadvantages

- Complex maths in determining the size of cyclone as there is currently no research where the particles involved are large and where large particles need to be left in the air stream.
- Due to the size of the particles, the dimensions of the cyclone would be too large for this project.

4.4.2 Horizontal Sorting Chamber or Fluidized Bed

Taking a step back from the Cyclone Separator is the sorting chamber. It is proposed that if an airstream carrying material is suddenly slowed in velocity then the heavier particles will fall from the air stream if the drop in velocity is such that the drag force on the particles is no longer larger than the gravitational forces.

In designing a sorting chamber the aim is to construct an expansion chamber that will cause the air stream velocity to drop such that the grain will fall out of the air stream and the husks will remain entrained in the stream. The possibility of the design is realistic and further testing will determine whether the possible design is feasible.

Advantages

- Some existing research to base designs on.
- If designed correctly the separation is quite robust and reliable.
- Light and portable if designed with the correct material.
- Has the possibility to be quite efficient and gentle on the grain once set up and tuned correctly.
- Fits into the pneumatic system and dumps the grain and carries the trash and dust to a deposit area away from the operator.
- Self cleaning between plots.

Disadvantages

- Complex maths in determining the size of the expansion section as there is currently no research where the particles involved are large and where large but light particles need to be left in the air stream.

4.4.3 Vibration Table

The concept of the vibration table is taken from several food and industry processing systems. In these systems a vibrating table is used to feed or move particles both vertically and horizontally. Currently few people have carried out research on the possibility of using vibration as a separating mechanism. While research was undertaken no literature was found, one sales man did mention that his company was working on such devices but since it was still a concept their company had still not published any papers on it.

Due to the lack in previous research a simple test was carried out to determine the possibility of such a mechanism. The mechanism was made using Lego components and the drive was a portable drill connected to an input shaft on the small model. After some time altering the settings and speed of the drill, the conclusion was made that the further development was going to take time. Therefore due to time constraints the development of a vibration separation system would be outside the scope of this project.

Advantages

- If designed correctly the separation is quite robust and reliable.
- Light and portable if designed with the correct material.
- Has the possibility to be quite efficient and gentle on the grain once set up and tuned correctly.

Disadvantages

- Since no air flow is involved, this separation has the possibility to allow particles close to the properties of grain to follow the grain and contaminate the sample.
- Large amounts of testing would be necessary to determine the exact relationships that need to be designed for.

4.4.4 Aspirators

The concept of an aspirator as explained in chapter 2 is quite simple and can be easily designed and optimized to work in both an efficient manner as well as being quite robust and safe.

In 1979 I. G. Farran and R. H. Mac Millan [Farran & MacMillan , 1979,]submitted a research paper titled “Grain-Chaff Separation in a Vertical Air Stream”. In this paper it is recognized that there are several factors that influence the efficiency of such a system and conducted tests to determine the most efficient design for maintaining a clean sample without compromising the loss of grain with the chaff in a vertical air stream separator. Due to the work already conducted the results found in the paper will aid the design of such a system and will act as the starting point for the development of the Aspirator for this system if the aspirator is to be used.

The only draw back of such a system is the need for two separate air streams, a conveyance stream and a stream for the separation. Due to the size of the project it would be unreasonable to use two fans to run this system as the cost will start to rise and will be a little over kill. The other option is the possibility of splitting one air stream into two so that there are two streams that can be used for different purposes. A similar situation can be seen in many pneumatic conveying systems that are used in agriculture.

Advantages

- Extensive research to base designs on.
- If designed correctly the separation is quite robust and reliable.
- Light and portable if designed with the correct material.
- Has the possibility to be quite efficient and gentle on the grain once set up and tuned correctly.
- Fits into the pneumatic system and dumps the grain and carries the trash and dust to a deposit area away from the operator.

- Self cleaning between plots.

Disadvantages

- Using one fan, the air stream must be split.
- A diffusing mechanism is needed to remove the product from the conveyance air stream to feed into the aspirator.

4.5 Analysis and Discussion of Proposed System

The analysis of the possible designs is an important part of the design process as it is in this section where the design becomes focused towards designing one system using one set of concepts and fitting them all together.

According to the design specifications and the scope of the hand held harvesting system several of the above proposals will not align with the project and hence will be discarded. From the above list there are some concepts that will increase the simplicity of the system and will be rated higher than a component that will increase the complexity of the system.

The removal of grain from the crop is an important stage as it is the main place where the interaction between operator and device takes place. From the advantages and disadvantages listed above it is quite clear that the beater concept will have far less OH&S issues than the traditional cutting method. Also the beater concept will eliminate the need for a thrasher hence making the system far less complex than if a thrasher was needed. From this it is clear that the system should incorporate the beater concept as it will reduce OH&S risks and will reduce the complexity of the system.

Since there is now no need for the thrashing part of the system the next component to analyze is the separation component. From the discussion above where the advantages and disadvantages are listed, the elimination of one of the possible components are easy. The vibration table has the possibility of working but due to the time constraints and the funds available to test such a device the vibration table will not be used in this

system. This leaves only three choices and due to the complex maths involved in the cyclone design of large particles the only real option is the horizontal sorting chamber. The vertical air stream separator has been ruled out as it is not desirable to split the air stream if possible.

Once this system was decided upon pre prototype trials were carried out to insure that the concept of a horizontal sorting chamber would work. After several configurations and dimensions were build and tested it was deemed that the concept at this point was not working. The samples collected from the trials didn't appear to have even remotely separated the chaff from the grain, it was more of a random splitting of both the grain and the chaff as to what was collected in the bottom of the horizontal sorting chamber. One of the samples taken from the horizontal sorting chamber can be seen in figure 4.3. This sample was made up of around 70 grams of grain and 40 grams of husk material. In the photo it can be noted that only husk is visible and that the sample is not useable for post harvesting analysis.

From this initial prototyping the choice is clear; the air stream has to be split and the vertical air stream sorting chamber needs to be designed as part of this system. Such sorting chambers have already been tested, therefore, the testing of such a system will only be required once the system is completely built.



Figure 4.3: Picture of one of the samples taken of the Horizontal Sorting Chamber

4.6 Conclusion

From the above discussion, the most advantageous system that will follow all the guide lines set out by both the DPI& F and Biosystems Engineering is as follows:

The system will comprise of a beater like removal of the grain that will be powered using the Viking garden blower. The beater will be attached directly on to the front of the blower to eliminate the need for two electric motors. The material taken from the plant will then be added to the conveyance air stream by means of a venturi and conveyed to the vertical air stream sorting chamber where the grain will be collected and the trash will be discarded away from the operator.

The following chapters will discuss the design and lead into the testing of the actual prototype system.

Chapter 5

System Design

5.1 Introduction

In this chapter, we will detail the mathematical and practical process that was taken to obtain the theoretical and actual design of the prototype system. The system that will be designed comprises of a beater like removal of the grain to a vertical air stream sorting chamber where the grain will be collected and the trash will be discarded.

In this system the pneumatic conveying will be undertaken by a garden blower made by VIKING. This blower was chosen due to its availability and ease of adaptation to the system. Since the users of this garden blower don't need to quantify the volume of air being blown the fan did not come supplied with a fan curve, determining the fan curve makes up the first part of the design process. Once the fan curve is known then the volume of air being blown by the VIKING blower is also known. The design of the vertical air stream sorting chamber is then possible according to the volume of air the blower is rated to.

The vertical air stream sorting chamber is the critical element of this system, as this is the part of the system where the sample is obtained from the trash and it is the point where failure can take place. Failure at this stage is potentially losing the seed sample as this is a year of research wasted if the sample is lost.

Designing the beater front was a combination of prototyping and computer modelling. Once the initial prototype was built it was easy to verify that the concept worked and that this concept had the possibility to be added to the system. Once the concept was verified the next stage was to build a unit that was adaptable with the system. Since the garden blower is already being used in this system, it was decided that the power to drive the stripper would come from the garden blower hence the beater would attach to the front of the blower and be driven directly off the fan. Due to the nature of the stripper and the lack of known mechanical properties of the crop being used, determining a mathematical model of the process of the beating would be near impossible.

5.2 Fan Curve

Fan curves, or more commonly know as pump curves, are characteristic to each fan and are dependent on fan speed as well as the actual fan. Since we are using an electric fan the motor has only two speed, on or off. The fan curve has two parameters, discharge and pressure head. For most fans as the pressure increases the discharge decreases.

To determine the two parameters and to allow the plotting of the curve, water columns were used to allow the measurement of pressure head. This is simply a U-Tube with a small amount of water in the ‘U’ and one end exposed to the pressure inside the outlet of the fan and the other end opened to atmosphere. As the pressure increases inside the outlet chamber the two water columns will move according to the pressure inside the chamber. A simple measurement of the difference in height will allow the calculation of pressure.

To determine the discharge the velocity can be measured and assumed to be uniform across the section, therefore, the discharge is simply the velocity multiplied by the cross sectional area. Reference [Chadwick, Morfett & Borthwick, 2004,].

$$Q = AV \tag{5.1}$$

The velocity was measured using a pitot tube see figure 5.1; a pitot tube is a device

that simply measures the velocity head of the moving fluid. The device is a small tube that is placed in line with the flow. A small opening where the air pushes into the opening gives velocity head, it also has small openings that measure the static head. Then these two small tubes are attached to a manometer where the difference in water column height is the velocity head. The static head is connected to the other end of the manometer as this insures that it is only velocity head being measured and not the static head.

(a) Pitot tube

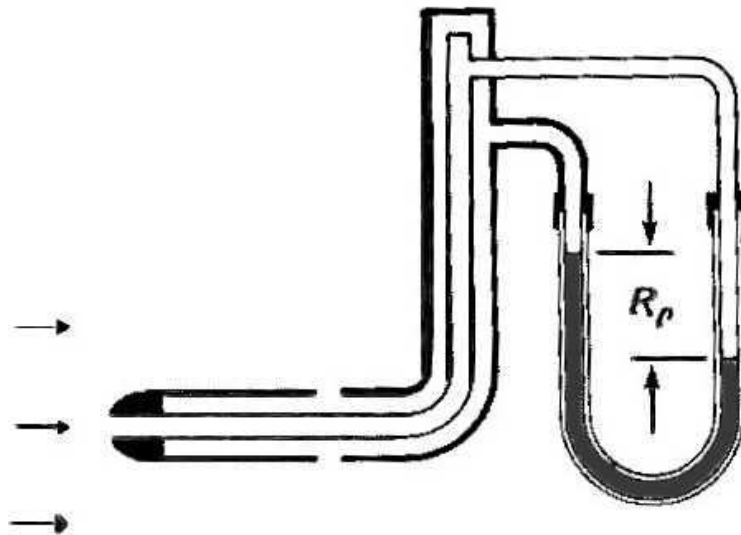
**Figure 5.1: Pitot Tube Velocity Sensor**

([Chadwick, Morfett & Borthwick, 2004,] pp 43,)

Once velocity head is measured the water heights can be calculated into velocity to allow the plotting of the fan curve. Since:

$$U = \frac{V^2}{2g} \quad (5.2)$$

$$V = \sqrt{U2g} \quad (5.3)$$

$$V = \sqrt{\frac{\rho_{water} \times waterheight}{\rho_{air}} \times 2g} \quad (5.4)$$

Reference [Chadwick, Morfett & Borthwick, 2004,]

The velocity will be in ms^{-1} if the water height is also in metres.

The measured values of velocity head and static head can be seen in table 5.1.

Table 5.1: Measured data for fan curve

Static Pressure (mm)	Velocity Head (mm)
0.22	0.00552
0.31	0.0156
0.26	0.0397
0.24	0.0587
0.16	0.107
0.1	0.1468
0	0.1987

Using the values in table 5.1 and equations 5.4 we can determine the fan curve for pressure against velocity. Using equation 5.1 we can then determine the full fan curve of pressure against discharge given that the discharge pipe is 63.5mm. See table 5.3 for the recalculated values of the fan curve. Also see figure 5.2 for the actual fan curve.

Table 5.2: Velocity versus pressure head, calculated for fan curve.

Static Pressure (m)	Velocity (ms^{-1})
0.22	9.5
0.31	16
0.26	25.5
0.24	31
0.16	42
0.1	42.75
0	57

Table 5.3: Discharge versus pressure head, calculated for fan curve

Static Pressure (m)	Velocity (m^3s^{-1})
0.2	0.112
0.15	0.097
0.115	0.084
0.11	0.083
0.06	0.061
0.04	0.050
0.015	0.030
0.005	0.0177

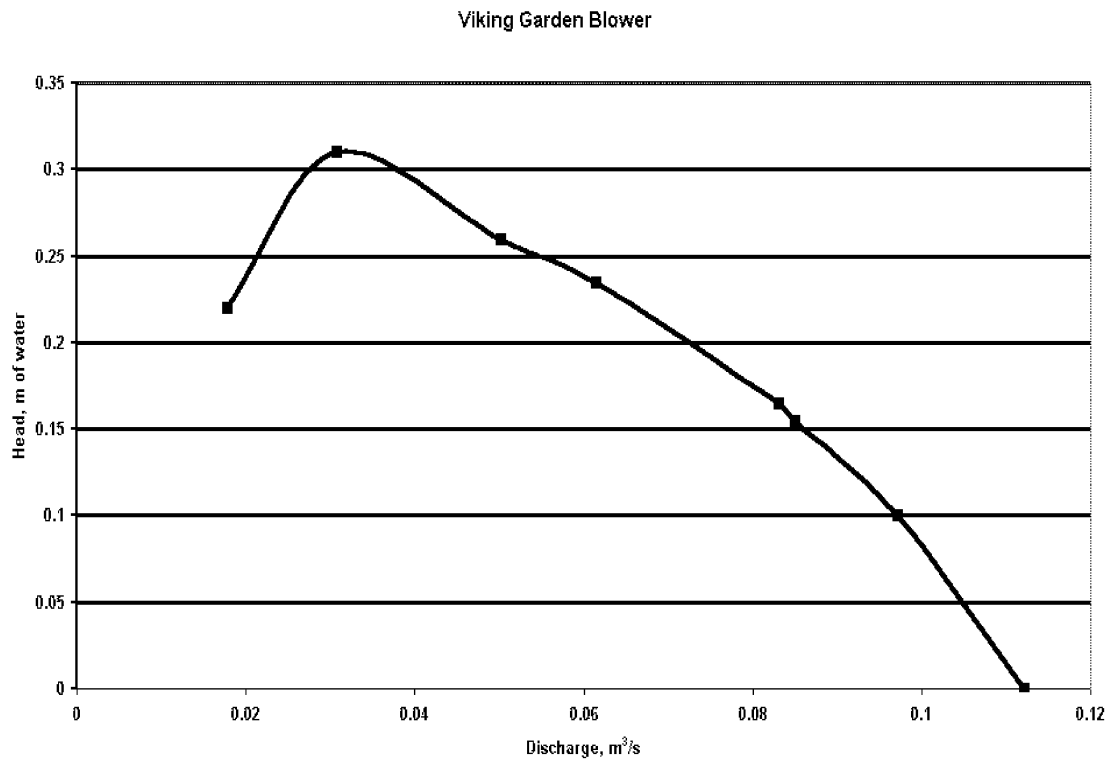

Figure 5.2: Viking Fan Curve

5.3 Vertical Air Stream Sorting Chamber

It is proposed that a chamber could be designed to allow the air stream carrying the grain and husks to be diffused allowing the crop material to be dropped into a vertical moving air stream. This vertical air stream will allow the grain to fall through the air stream while carrying the items up that have a bulk density less than that of grain. It is noted that all husks and related material taken by the stripper are of less bulk density than that of the grain.

Using the results from the referenced paper [Farran & MacMillan , 1979,] it is shown theoretically that the the best feed angle for the injection of the material into the vertical air stream is at 60^0 to the vertical. With a feed angle of 60^0 the vertical velocity of the air vertical air stream should be between $3ms^{-1}$ and $6.8ms^{-1}$. Tests conducted by the referenced paper [Farran & MacMillan , 1979,] show that at an air velocity of around $3ms^{-1}$ the cleaning efficiency is the best but this is for an angle of 90^0 to the vertical for the injection of material. Unfortunately this 60^0 feed angle efficiency was not the best seen in the results. They believed it was due to the lighter particles being shadowed, in a sense, by the heavier grain.

For our system this may not be a consideration, if we are to feed the material into the air stream using gravity the higher feed angle will be the most achievable without a secondary motor. In the paper it suggested that if the higher feed angles are used then a higher velocity is needed to insure that complete separation is reached.

Also a consideration is the feed rate. Due to the feed being a gravity type, the feed rate will only be controlled by what is entering the system at the collection point. In the paper all the feed rates were controlled ensuring that an even amount of material was always entering the air stream. From the testing of the prototype this will not be a foreseeable problem as the stripper has only a limited capability of removing a small amount of product at any one time. Due to the limitation in the stripper it will ensure that the sorting chamber won't get overloaded with too much product at any one time.

Since the design velocity inside the chamber is known the actual chamber can be designed using this velocity. More importantly from the design of the chamber it can be

determined what volume of air is needed to create this velocity through the given area of the chamber. For simplicity it was decided that the vertical section of the chamber will have a side of 100mm giving it a cross-sectional area of 0.01 m^2 . This dimension was chosen both for simplicity and for ease of manufacture of the initial prototype.

Since we know that the maximum discharge needed will be 3.0 m s^{-1} and the area is 0.01 m^2 then using equation 5.1 we can determine the volume of air needed to drive the separation of this size chamber.

$$\begin{aligned} Q &= AV \\ Q &= 6.80 \times 0.01 \\ Q &= 0.068 \text{ m}^3 \text{ s}^{-1} \end{aligned}$$

As well as the velocities inside the chamber, the chamber must have a collection point that is designed in such a way that when the grain is collected that all the sample is taken. The design of such a collection point will need to be like a tapered section falling towards a slide door. When collection takes place this door is fully removed and all the section is left clean, the slide is replaced and the sorting chamber is ready for the next plot.

The vertical section of the sorting chamber, as mentioned earlier will be a cross section of 100mm by 100mm. This section needs to be a height such that the separation can take place and eliminate the loss of the grain. It was chosen to be a height of 900mm. The entry of the material occurs at a height of 450mm above the base of the vertical section. This distance was chosen as it will allow time for the airstream to reach a uniform flow across the section before the material enters the vertical stream. Schematics of the prototype can be seen below in figure 5.3.



Figure 5.3: Prototype of the Sorting Chamber

5.4 Pneumatic Design

In this section of the design the focus is on the pneumatic section of the system. The pneumatics that are needed for this system are:

- air stream to convey the material from the stripper to the sorting chamber.
- an air stream to use as the sorting stream in the sorting chamber.

Additional to these two streams a device must also be designed to:

- introduce the plant material from the stripper into the conveying air stream.
- a device to diffuse the air so that all the product falls under gravity.
- A splitting system that has the capabilities of controlling one stream flow.
- a fluid exit point away from the separator that does not induce additional pressure to the system.

Section 5.3 outlined and determined the needed quantity of air for the sorting chamber to function, as well as the maximum quantity of air needed and control over the exact amount of air being split. To be able to adjust the actual amount of air being split to the separator, the split line must then pass through a control valve. This control valve will be on the separation line and, therefore, will control the amount of air allowed to pass through the splitting system. The remaining air will go to the conveyance line.

5.4.1 Splitting Device

The splitting device in this pneumatic system can be made easily. In reality all that is needed is a branch off the conveyance line with a control valve to adjust the exact amount of flow through the branched line. To ensure that this branch will flow at the pressure and maximum velocity possible, the branching section of the conveyance line must be such that the air stream is subjected to the full opportunity to pass to the branch line.

Since the Viking garden blower is being used, the pressure of the pneumatic system is quite low, this pump creates high volume at a low pressure. The implication that this has on designing the splitting device is that the device must not induce back pressure on the system as volume discharge will be lost if this happens.

In reality all that is needed is a right angled pipe bend to be placed inside the conveyance tube, up stream of the plant material induction point. The critical element of this will be the size of the cross-section of the bend and the relative size of the outside diameter of the bend compared to the cross-sectional hole of the bend. Once this bend is in place then the valve can be placed just down stream of the inserted bend. This gives the operator the ability to adjust how much air is allowed to enter the bend and how much is forced to pass around the angle bend inside the conveyance pipe.

The reason the cross-sectional area is important is that it is the dimension that determines the amount of air that will be diverted by the device. The reason the outside diameter of the bend is important is that if the bend is made from material that takes up too much space inside the conveyance pipe, a pressure build up will occur due to the air trying to move past the obstructed air stream.

Unfortunately, due to time restriction, a full mathematical analysis of the splitting device can not take place. Due to the compressibility of the fluid and the intended nature of the device the maths associated with a full design is outside the scope of this project.

The design of the splitting system for the prototypes will, therefore, be a one inch steel pipe ninety degree bend. Much like a large pitot tube. This bend will be cut into the conveyance line just up stream of the induction device and will have a control valve in the new branched line. If, after the prototype is built, the separation stream of air is deemed to be less than that which is required to achieve adequate separation, a larger diameter bend will be exchanged for the existing bend. This will increase the flow through the separation line and will try to minimize the increase in pressure in the system. See figure 5.4 for a schematic of the device. This figure is not the exact system explained above but the same principle applies with the splitting of the air stream.

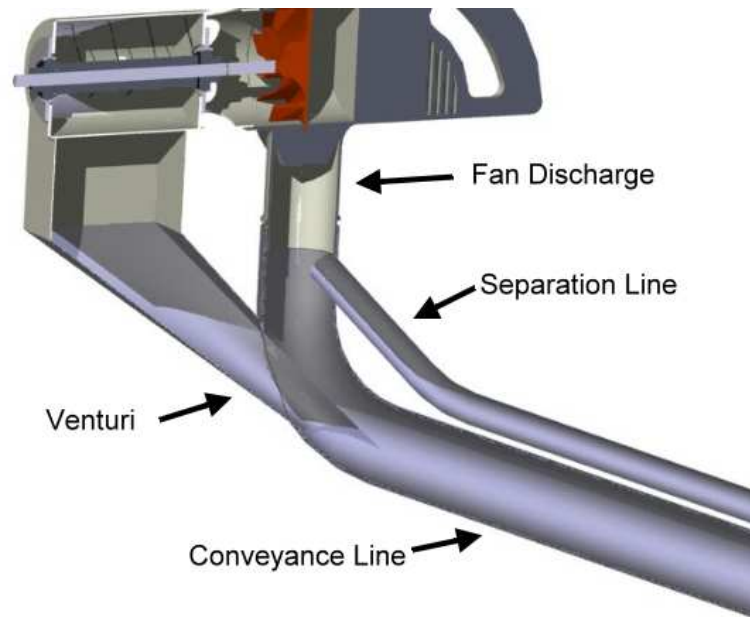

Figure 5.4: Sectional view of the Air stream Splitting System

5.4.2 Induction Device

For this project a simple induction device needs to be created so that the material that is stripped from the plant doesn't need to pass through the fan but can be introduced into the conveyance air stream down stream of the fan. This is desirable, as during early testing it was observed that the viking fan seemed to damage a great percentage of the whole grains that passed through the fan. Due to this damage it is now desirable to introduce the material into the air stream down stream of the fan.

The most simple device or way of introducing material or fluids into a stream of fluid is by way of a venturi. A venturi for fluid mechanics is a contraction in pipe diameter which causes the fluid flow to increase in velocity, hence where the velocity increases the pressure decreases. It can also be shown that just downstream of a venturi the pressure is also reduced, creating a suction just downstream of the stream disturbance. Figure 5.5 shows a schematic of a venturi and the manometer that would show the pressure just up stream relative to the pressure just down stream. It is proposed that if a smaller pipe entered at the point of low pressure then a suction would be formed through the inserted pipe. To properly design such a device it will take time to get it working

efficiently. Since this project is not concerned with the exactness of the prototype, it is possible to come up with a device that may not be the most efficient. As long as it introduces the plant material into the air stream, it will achieve the objectives of the induction device.

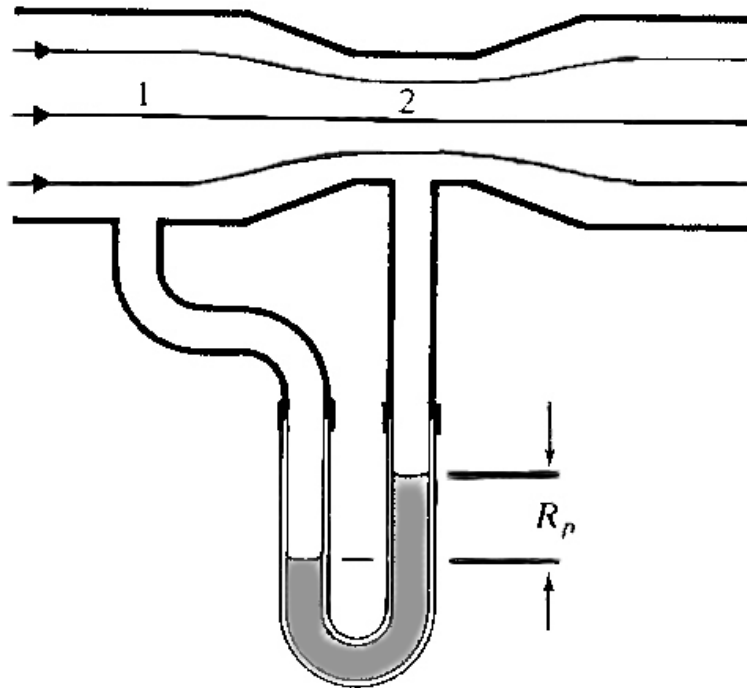

Figure 5.5: Sectional view of a Venturi and associated pressure
([Chadwick, Morfett & Borthwick, 2004,] pp 44,)

In reality a simple venturi can be created if a pipe is inserted into a stream of fluid so that the inserted pipe creates a disturbance and increase in velocity as the fluid passes the inserted pipe. This increase in velocity will drop the pressure as well as creating eddies around the bottom of the inserted pipe. Now fluid will begin being sucked into the fluid stream through the inserted pipe by the pressure drop and, therefore, an induction of fluid will occur. If the conveyance pipe is large enough a relative large pipe can be inserted into the stream to create this venturi action.

The restriction of this device is that the material has the opportunity to become lodged inside the pipe if the device that is inserted pipe is undersized. This means that if the venturi is too small the husks will block the venturi and, therefore, the system will now not be self cleaning or even reliable. A note must be made, that the material will be

falling under gravity into the venturi. This means that the material is already falling in the direction of the induction device and, therefore, will allow the induction device to be slightly inefficient as the inefficiency will be made up by the motion of the material.

The induction system for the first prototype system will be a 50mm pipe inserted at an angle of around 60° to the stream lines. Placing a pipe of this diameter inside a pipe of only 76mm will create a similar effect to an orifice, in that the fluid will be required to increase in velocity around the inserted pipe, hence reducing the velocity at the downstream end. At the downstream end, the opening of the inserted pipe will be located, there a suction will occur through the inserted pipe. Figure 5.6 is a sectional view of a conventional venturi feeding system.

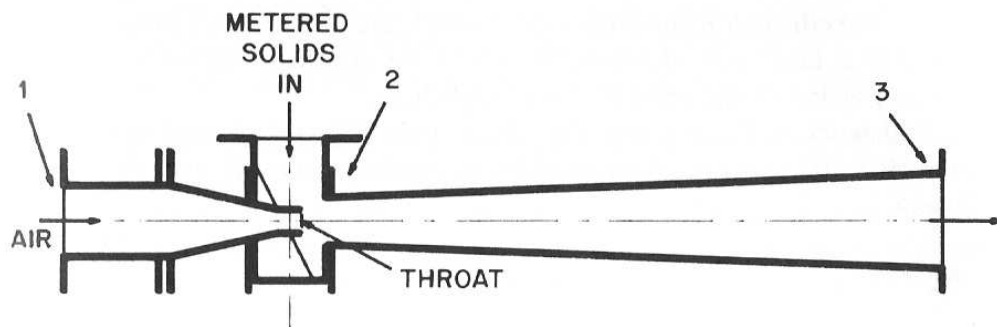

Figure 5.6: Sectional view of a typical venturi

([Klinzing, Marcus, Rizk F. & Leung, 1997,] pp 247,)

5.4.3 Diffusing Device

The aim of the diffusing device is to extract all the material that is entrained in the air stream coming from the stripper hand piece. Once the material is extracted, it then falls under gravity while the fluid exits via a secondary exit port. The conveyance flow is through a three inch smooth pipe where the velocity is far greater than the velocity needed to entrain the material being conveyed. The approximate velocity is 30 ms^{-1} , it is assumed that all material entrained in the fluid is also at a velocity near that of

the fluid.

From the research carried out for this project it can be seen that the best diffusing device is going to be a cyclone. A cyclone is efficient for separating particles greater than 10 microns. This means that an efficient cyclone can be designed for all the grain as well as all the trash, therefore, all the material being conveyed will be diffused from the air stream.

The design of the cyclone will come from the reference book by [Davis & Cornwell, 1998,]. In the design of the cyclone, a diameter of the barrel is chosen and then all the following dimensions are just a ratio compared to the barrel diameter. Then the collection efficiency is determined for a cyclone of the predetermined size. It must be noted that as the cyclone decreases in size, the pressure drop across the cyclone is increased. Therefore, the cyclone can be as compact as needed as long as the power requirements are available to use a small cyclone. Since there will be a venturi used upstream of this cyclone it is necessary to keep the pressure drop as low as possible else it will inversely impact the venturi.

See figure 5.7 for the location of each dimension. The ration of the dimensions are tabulated below.

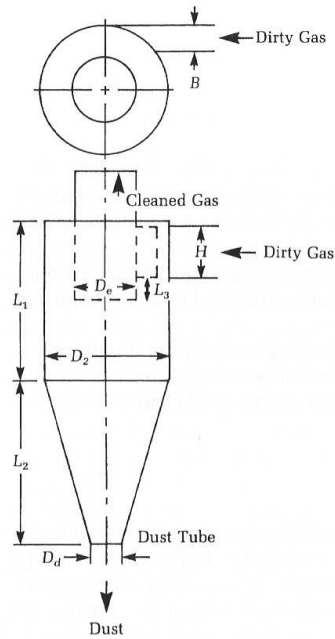

Figure 5.7: Sectional view of a cyclone
(Taken from Davis & Cornwell pp526)

Table 5.4: Dimension Ratios for a Standard Cyclone
(Taken from Davis & Cornwell pp526)

Dimension	Ratio
Length of Cyclone	$L_1 = 2D_2$
Length of Cone	$L_2 = 2D_2$
Diameter of Exit	$D_e = 0.5D_2$
Height of Entrance	$D_e = 0.5D_2$
Width of Entrance	$B = 0.25D_2$
Diameter of Dust Exit	$D_d = 0.25D_2$
Length of Exit Duct	$L_3 = 0.125D_2$

Once the actual dimensions are decided on then the efficiency can be determined for the cyclone. The actual efficiency in a percentage form, is determined from a plot of efficiency against the ratio of the mean diameter of the particles over the cut diameter of the particle where 50% collection is achieved or $d/d_{0.5}$. This figure is found in page

527 of Davis and Cornwell.

To determine the diameter of a particle with a collection efficiency of 50%:

$$d_{0.5} = \left[\frac{9\mu B^2 H}{\rho_p Q_g \theta} \right]^{0.5} \quad (5.5)$$

Where:

- $d_{0.5}$ = cut diameter, the particle size for which the collection efficiency is 50%
- μ = dynamic viscosity of gas, Pa·s
- B = width of entry, metres
- H = height of entrance, metres
- ρ_p = particle density, kg/m³
- Q_g = gas flow rate, m³/s
- θ = effective number of turns made in traversing the cyclone as defined in Equation 5.6

The value of θ can be determined by the following equation:

$$\theta = \frac{\pi}{H} (2L_1 + L_2) \quad (5.6)$$

Reference [Davis & Cornwell, 1998,]

Then if we are to chose a value of 0.25m for the diameter of the cyclone the dimensions on the design will be as follows in table 5.5:

Table 5.5: Dimension for a Standard 250mm Cyclone

Dimension	Value
Length of Cyclone	0.5
Length of Cone	0.5
Diameter of Exit	0.125
Height of Entrance	0.125
Width of the Entrance	0.625
Diameter of Dust Exit	0.625
Length of Exit Duct	0.03125

Then with these values and using equation 5.5 and assuming that

$$\begin{aligned}
 Q_g &= 0.11m^3s^{-1} \\
 \mu &= 18.5 \times 10^{-6}Pa \cdot s \\
 \rho_p &= 600 kg/m^3
 \end{aligned}$$

Therefore θ is:

$$\theta = \frac{\pi}{0.125} (2 \times 0.5 + 0.5) \quad (5.7)$$

$$\theta = 37.7 \quad (5.8)$$

Therefore $d_{0.5}$:

$$d_{0.5} = \left[\frac{9 \times 18.5 \times 10^{-6} Pa \cdot s \times 0.625^2 \times 0.125}{600 kg/m^3 \times 0.11m^3s^{-1}} \frac{1}{37.7} \right]^{0.5} \quad (5.9)$$

$$d_{0.5} = 5.72 \times 10^{-6} \quad (5.10)$$

Now it is possible to determine the collection efficiency, for the grain diameter as the particle size which is about 2mm.

Therefore, our $d/d_{0.5}$ is 347. Since the table only goes to 10, it will be assumed that the collection efficiency is 100%.

A schematic of the design of the cyclone and the sorting chamber and how they will fit together is given below in figure 5.8.

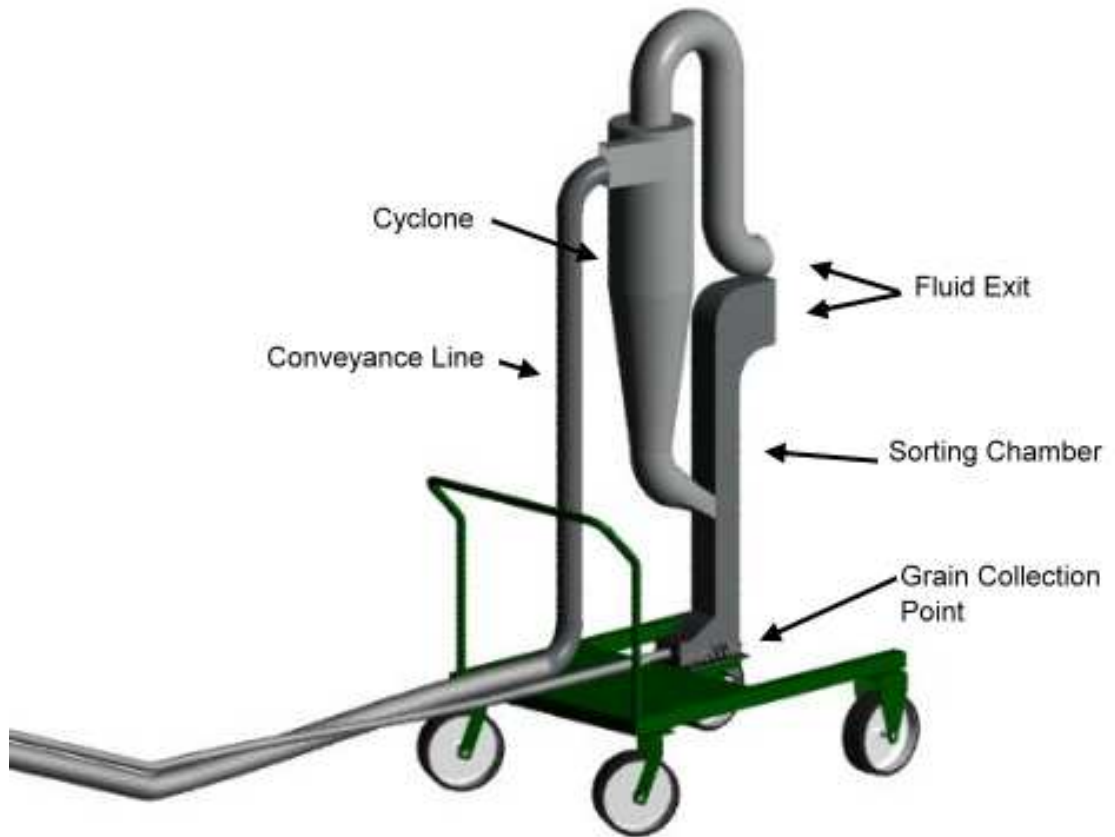

Figure 5.8: Pictorial of the Sorting System

5.4.4 Fluid Exit

The fluid exit is the final section of the pneumatic design; this section is where the fluid and any entrained particles are emitted to the atmosphere. There are a couple of design constraints dealing with this section, they are itemized below.

- Exit point must be away from operator so that the operator is not working in the dust from the harvesting process.
- Exit system must not add pressure to the system as this will change the properties of the venturi that has been designed up stream of the exit.
- The exit point must be away from the plot area. Due to the research, any grain

that is grown must all be removed from the plot otherwise it will contaminate next years results. Therefore, if grain is passed through the separator it must be exited away from the plot to avoid problems next year.

- The exit system must be either self cleaning or easily cleaned at the end of each day.

From the items above, it is quite clear that this section, though may be last will have some of the lasting effects on future research. This final section has to ensure that the harvesting of the plots doesn't effect the sustainability of the research method by introducing contaminating grain plants for next season.

There are two possibilities for solutions to the design problem of the exit system. The first solution involves attaching a pipe larger than the ones previously used so that a long section can be attached without increasing the pressure in the system by an unacceptable level. The idea is that a long section of this pipe is attached and carries the dust and residues coming from the top of the separator to a point, both away from the operator and the plots for next year. This air stream will also take the fluid coming from the diffuser. The exit will then just deposit the fluid and any entrained material into the atmosphere.

The second possible solution is to exit the fluid away from the operator but not off the site completely. Instead of exiting the fluid to the atmosphere like the previous, exit it into a coarse filter so that all the material coming from the harvester is collected, either in the exit filter or bag in the bottom of the sorting chamber.

The solution to this problem will only be solved once the end user starts using the system. This solution will also need to be site specific as at some sites it may not be appropriate to just exit the fluid to the atmosphere as there may not be a place that is not used for research purposes hence there is no place where contamination is possible. Also, if the plots are located in a residential area, there may be problems with emitting dust without into the atmosphere with out a filter.

At this stage the best solution will be to build both, have a section of tube that is the exit tube from the diffuser and the separator and either have a coarse filter that is

easily connected to the pipe or just leave it open to the atmosphere.

5.5 Conclusion

In chapter 3 it was discussed and outlined exactly what the aims of the project were. In the above chapter the design of a hand held harvesting system to suit these designs is outlined. Unfortunately, not all the objectives were reached. At this point the harvesting system is still only a prototype as listed in the above design. Due to this, the weight and compactness of the system is not what the objectives state them to be. Currently the handpiece is made out of steel, causing the hand piece to be about 6 to 7kg heavier than what it should be. Also at this stage the sorting and pneumatic system is not as efficient as it has the potential to be. This is why this design is still a prototype.

The prototype system utilizes a VIKING garden blower as the power and pneumatic device. The grain is removed from the plant along with the husks using a beater type design. The material then falls under gravity and is inducted into the conveyance air stream using a venturi. Just prior to the venturi, a secondary separation line branches off the main conveyance line, this line is then controlled to be used as the vertical separation air stream. The conveyance line continues to the top of a standard cyclone with the material entrained, where the air stream is diffused allowing the material to fall under gravity and the air exits out the top end of the cyclone. The material under gravity is introduced to a vertical moving air stream at an angle of around 60° . At this point the grain is left to fall under gravity but the material which has a small bulk density to grain is carried vertically with the air stream. All the material the harvester takes in has a bulk density less than grain. At the exit point the material exiting the vertical air stream connects back with the air exiting the top of the cyclone and both streams continue to atmosphere away from the operator. The grain that has fallen is trapped in the bottom of the vertical chamber by a slide gate. This gate is removed and the grain sample is collected and placed into a sample envelope.

This system works and achieves all the objectives set out in section 3.2 and 3.3.

The next chapter will discuss and evaluate the system and determine how to turn the prototype into a final design.

Chapter 6

System Testing and Evaluation

6.1 Introduction

The testing and evaluation section of the design process gives an indication to both the designer and the client that the system that has been designed, can accomplish all the requirements in the design brief or objectives for the system. The design brief or design objectives for this project can be found in chapter 3. In chapter 3 it is discussed what the actual requirements for the system are. In this chapter an analysis will take place where the system will be evaluated against the objectives for the project.

6.2 System Testing

Testing on the final testing is currently not possible. Due to the timing of this project and the completion deadline, the crops that this harvesting system will be harvesting is just simply not ready. Therefore, the complete testing of this system in field conditions will not appear in this report. However, some testing can take place, as already stated initial testing of each component has already been completed. Also from the previous section it can be noted that the only concept that is utilized by the system that has not already been tested is the beater type handpiece. Earlier work completed on the vertical airstream sorting chamber ensures that the design of the sorting chamber in

this system will work and does not need the testing like some other components.

The items of the system that are needing to be tested are the stripper type hand piece, and verification of the pneumatic system and the diffusing system that delivers the material into the sorting chamber. Testing of these three systems will make up the majority of the testing for this project.

The following items are taken from chapter 3 and are the design requirements specific to this part of the system.

- Avoid cross contamination of plots. In any research the aim is to receive good quality data. If contamination occurs the data for that plot is no longer valid and cannot be used for further research.
- Self cleaning between plots. This attribute of the harvester is a must, as without the self cleaning mechanism the contamination of plots can be occurring within the harvester.
- Minimize OH& S risks. This project will be designed to reduce the possible risk of injury to the user and any persons in the vicinity of the harvester.
- Insure ergonomic design to allow user extended periods of operation
- Due to the research nature of the harvested crop, the new design must look to minimize chances of losing the research data, or damaging the data in such a way that it is no longer good for the intended purpose of the research.

6.2.1 Beater Type Handpiece Testing

From the items above the only design criteria that needs to be tested for is whether the beater causes damage to the grain, effectively making the data collection process a failure. The other criteria are more checks with the results being either yes or no, whether the damage criteria is more of a test that needs data to ensure that the system is working correctly. The criteria where the testing is more checking, then acquiring data will be discussed in the evaluation section.

Seed Damage Testing

Due to the lack of available ripe barley that can be tested, this section cannot be completed. Without some barley samples with the same mechanical properties as they would have when they are being harvested in the trials, it is impossible to accurately test for the damage that the beater is incurring. The main mechanical property is moisture content; this property has the potential to giving false results. If the test were carried out on heads of barley that are high in moisture content then the chances of damaging the seeds are less. As the moisture content is removed from the barley during the ripening process the grains become more fragile and prone to cracking.

The other problem is removing all the husks from around the barley. The innermost husk is actually where the black point is found in barley. Unlike wheat where a clean grain is the final product, barley is more of a textured surface with a husk like material being the outer surface of the grain. During the beating part of the system it may happen that this part of the grain is removed; if this happens then the research is void. Since the mechanical properties of the current barley plots are preventing the testing of such outcomes it will be desirable to optimize the handpiece and reduce the rotational speed of the beater, this will ensure that the grains of wheat and barley will only be removed and not damaged.

6.2.2 Pneumatic and Diffusing System Testing

The diffusing system is a critical part in the system, the diffusing system is where the material is transferred from the conveyance line to the vertical air stream sorting chamber. The proposed system to diffuse the air stream is a cyclone separator. This cyclone has been changed from the design in chapter 5 to allow for a simpler and cheaper test. The main change to the cyclone is the exit point, the designed exit point is that a tube protrudes into the barrel of the cyclone by a calculated distance. This protrusion forces the air to circulate around it and ensures that only the clean air is extracted. For this test the tube is not inserted into the barrel, instead on the top of the cyclone is an exit port the same size as what the tube would be. Since the material is quite large, the efficiency of this cyclone will still be high. Also the cyclone is meant to

be sealed; this is undesirable as a continuous flow of material into the sorting chamber would be ideal. Due to this the cyclone has an open base but the diameter of the exit is smaller than it was designed to be. Therefore a greater restriction will be placed on the air exiting through the base, hence the majority of air will leave via the top exit. This is the reason the velocity of the air leaving the bottom of the cyclone needs to be tested.

The main test is verifying the velocities of the airstreams that are being used in different processes. The three main velocities are:

1. Velocity of fluid entering the cyclone. (V_{in})
2. Maximum achievable velocity through the sorting chamber. (V_{sort})
3. The Velocity of fluid leaving the bottom of the cyclone. (V_{bot})
4. The Velocity of fluid being drawn into the venturi. (V_{ven})

The test system can be seen in figure 6.1. This picture is not the complete system. In the picture the venturi is not connected to the place where the crop material exits the beater. The picture was taken after some testing where it was desirable to have access to the venturi. This is why in the picture the venturi is not connected to the beater handpiece.

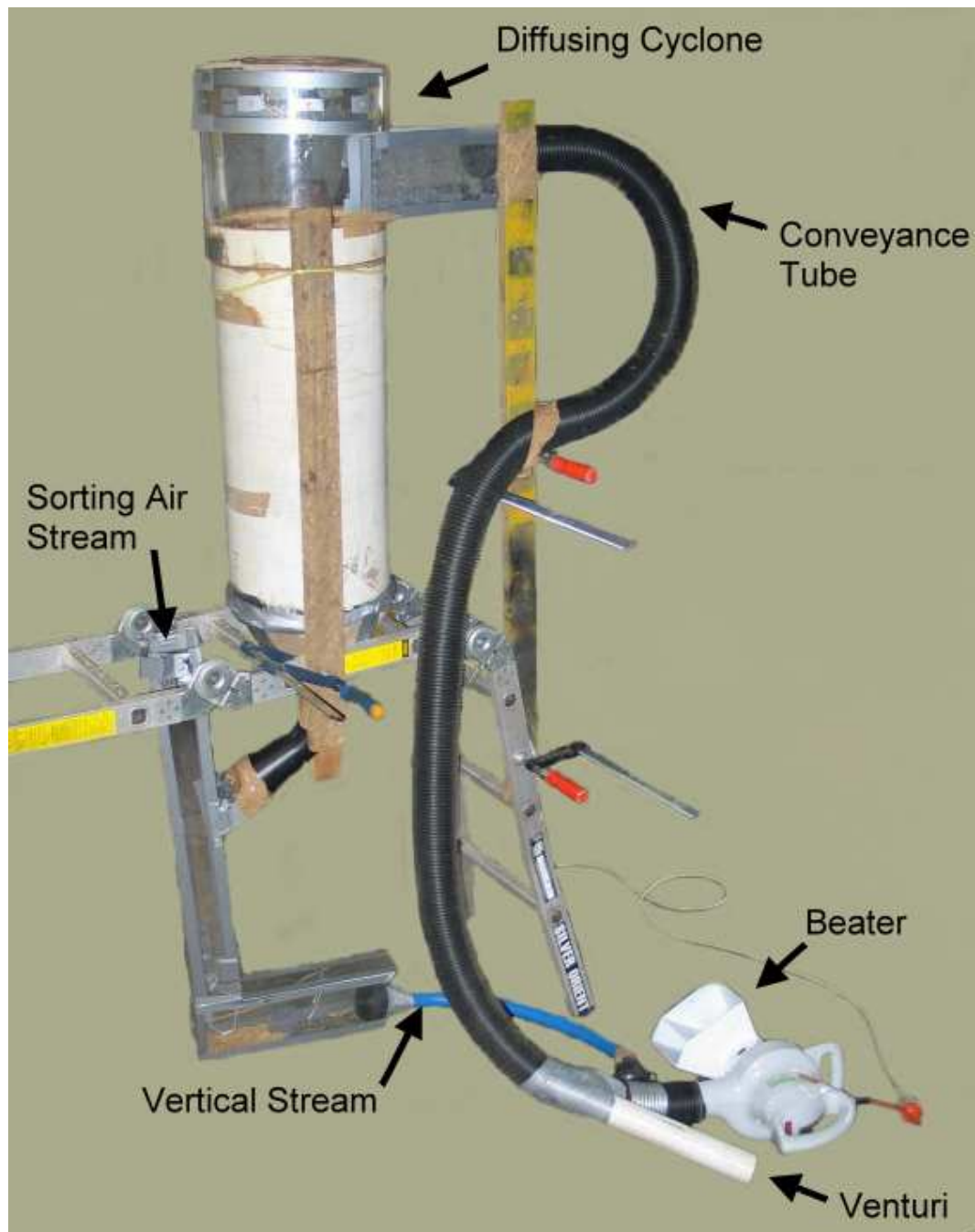

Figure 6.1: The full prototype as a working system.

Now that the prototype system is built, it is easy to see how well the vertical airstream sorting chamber works. One simple mixture of chaff and grain was added to the airstream to see if the diffuser and sorting chamber would work together. After the trial the material that was blown out the top of the sorting chamber was checked, in this check it was determined that no seed was lost in the sorting process. Also the

sample that was left in the bottom of the sorting chamber was extremely clean. The sample was at a point where the statical analysis could now take place. Figure 6.2 is a picture of the clean sample obtained from the bottom of the sorting chamber.



Figure 6.2: Seed sample from the sorting chamber.

The velocities measured for the system are tabulated below in table 6.1.

Table 6.1: Measured velocities of airstreams in the system

Fluid Stream	Velocity (ms^{-1})
(V_{in})	19.5
(V_{sort})	6.75
(V_{bot})	0.0
(V_{ven})	7.8

These measured velocities are positive in terms of the design verification, in that the velocities measured were almost the velocities that the system was designed for. Velocities measured in this test were measured using an impeller type measuring fan. This sensor is a small device with an accuracy of $\pm 3\%$. The only limitation with using such a device is that the actual fan may in some cases induce extra pressure on the fluid flow and hence reducing the velocity. To avoid this the sensor must only be placed after the exit of each stream to ensure that there is no extra pressure build up in the fluid.

From the results there is a clear indication that the system is behaving how it was designed to. In that the flow through the vertical sorting chamber is meant to be a maximum of $6.8ms^{-1}$ and the measured was $6.7ms^{-1}$. The flow for the venturi should be sufficient as the crop material has a terminal velocity much lower than this, the actual values can be seen in table 2.1. The other surprising value was the amount of air flowing from the bottom of the cyclone. Since this cyclone was designed to have a closed base, the implication of having an open base would be that a certain amount of air would then pass through the base. This is not the case; it was verified by shutting the sorting line off completely and then measuring the air flow still coming out of the sorting chamber. This value was measured to be zero and, therefore, it was assumed that the restrictions at the base of the cyclone was enough to force the fluid to exit out the top of the cyclone.

6.3 System Evaluation

This system will be evaluated according to the itemized points listed above.

6.3.1 Cost of the Prototype

To give a perspective of how much the prototype cost, the following table has been constructed. The table is missing the labor involved in assembly and simply looks at the material and the components purchased off the shelf. It can be seen that this system is cost effective as the whole system only costs \$950 for the components.

Table 6.2: Cost of the Prototype, broken down into components

Component	Cost
Viking Blower	\$ 210.00
Ozito Hedge Trimmer	\$ 100.00
Poly Carbon Sheet	\$ 75.00
Nylon Beater	\$ 140.00
Line Trimmer Cord	\$ 10.00
Mild Steel	\$ 30.00
Conveyance Tubing	\$ 140.00
Cyclone Barrel	\$ 40.00
Assorted Pipe Fittings	\$ 50.00
Silver Tape	\$ 30.00
Bearings	\$ 20.00
Shaft	\$ 7.50
Paint	\$ 5.00
Machining the Nylon	\$ 50.00
Lazer Cutting	\$ 25.00
Total	\$ 932.50

6.3.2 Beater Type Handpiece Evaluation

Cross Contamination

Cross contamination is undesirable in the research of black point. Cross contamination has the possibility of giving false results and making the research false. The major

cause of contamination is in the harvesting of a plot, where grain from an adjacent plot ends up in the sample. Pending on the plot, this type of contamination has the possibility of changing the statistical analysis of the seed sample. This may happen in many ways, the heads of grain may be confused at harvest and have two lots of heads harvested for the one sample; also there may be residual grain kept in the system and then get dislodged during the next plots harvest hence ending up in the second plots sample. A secondary consideration to contamination is in the actual system itself, if the system leaves grain or drops grain, the chances are that that grain will grow a plant in the following season. Due to the research plots always being in the same location it seems that to stop this self planting it is necessary to remove all grain from the plot location.

The handpiece designed for this system has a great ability to reduce contamination of the harvesting system. The handpiece is designed so that only a small amount of heads can be pushed into the harvester at any one time. This means that if the operator is trained correctly then the only heads that will be harvested are the heads of the actual plot that is being harvested. This handpiece is not a handpiece that is simply pushed through the crop, this handpiece needs operator interaction to feed the heads into the beater. This is not a OH&S risk as there is not place for the operator to put bodily extremities to become a health risk.

The beater handpiece has been designed along with the pneumatic system to insure that no grain has the possibility of collecting within the handpiece. The beater has been designed as a closed system; once the grain and plant material is in the system the only exit is either the grain collection point or the trash exit point. Once the crop enters the handpiece there is complete separation of the grain and heads from the stalks of the crop. This means that all the grain of each plot will be collected and removed from the site.

Self Cleaning

The major advantage for this system to be self cleaning is in regards to avoiding cross contamination within the system. The design of the handpiece is evident that this

handpiece is self cleaning. Due to the nature of the design there is no place where the plant material can collect. See figure 6.3. The design is that the beater rotates inside a smooth cylinder, the grain comes in contact with the beater dislodging the grain. The grain falls under gravity and is inserted to the airstream by means of a venturi. At no point in this system is there any place for grain or plant residue to collect.

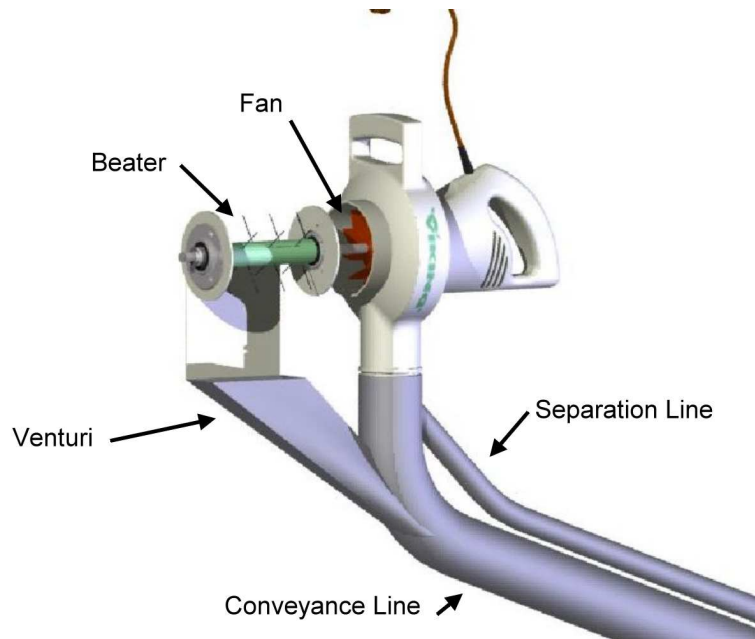

Figure 6.3: A view inside the beater handpiece design.

OH&S Risks

The major risk associated with harvesting systems is the use of shearing and cutting blades. In this there is a great chance for the operator to accidentally place the extremities of their body into the place where the cutting action takes place. In this design the cutting mechanism has been removed. The process of cutting and thrashing has been taken place by the safer method of beating the grain inside a contained cylinder. Although this beater is not cutting the plant as such, it must be noted that the beater is rotating at the same speed as the fan, 10 000 rpm at no load. From this it can be incurred that if a bodily part was to come in contact with the beater then some injuries may take place. Essentially the beater is a series of line trimmers, therefore, the beater can do the same damage as a line trimmer. Line trimmers can be dangerous if they

come in contact with bodily parts.

Ergonomic Design

The purpose of insuring that the handpiece is an ergonomic design is to insure that the operator can use the harvester for extended periods without negative effects on the operator. These effects include fatigue of both specific muscle groups and the total body, vibrational stresses on the operator and joint stiffness. Due to time considerations and the availability of test specimens it is hard to gauge the full effect of the system. With this in mind, the handpiece has been designed so that the actual handpiece is light and balanced when lifted from the handle.

Currently the handpiece is neither light or balanced. Currently the system is made out of a material that is far too heavy for a device that will be carried all day. The current weight of the handpiece is 10 kg. Also, since this beater connects to the front of the VIKING garden blower, the center of gravity for the blower is moved. The handles on the blower are correctly positioned for when the blower is just used as a stand alone machine. When the beater is attached to the front, the handles on the blower are then away from the center of gravity and hence the handpiece is not balanced.

The main recommendation to improve the handpiece is this exact problem. The problem of weight and balance can be eliminated with the one material choice. Currently the beater shell is made from mild steel, this is due to the ease of manufacture in the prototyping stage. Now that the system has been tested the prototype can be changed to a more ergonomic design. To do this, it is proposed that the shell is made from a light material, either an alloy steel or a plastic. If the weight of the beater can be reduced then both the weight problem and the balance problem would be eliminated.

6.3.3 Pneumatic System

The Pneumatic system for this project include:

- Fan or blower

- Splitting device
- Venturi
- Conveyance Tube
- Diffusing Device
- Existing System

This section of the system will also be evaluated using the design criteria that apply to this section.

Cross Contamination

Cross contamination of a pneumatic system is almost non-existent. The only time cross contamination will be a problem is if the conveyance tubes leak, since the system is a positive pressure system the material will be forced out of the tube if there is a rupture of the conveyance tube. To ensure this does not happen, the tube must be of material that is durable and able to withstand the environmental elements including the high temperatures and direct sunlight. The other parts of the pneumatic system won't incur any problems with contamination.

Self Cleaning

Self cleaning in this system is a must in terms of contamination. Since the pneumatic conveyor is the only form of transport the conveyance system is the most critical part of the system in terms of cleaning. The conveyance system cannot allow for material to be left behind, this will be where the contamination begins. To stop the material being left behind the system must not have any dead spots in terms of movement of a fluid. If there is a dead spot where the air is not moving, then the material has a possibility of collecting in that spot and not moving. To avoid this the pneumatic system must be a streamline system, so there can't be any sharp contractions or expansions in pipe diameters or any sharp bends. If the system can avoid having these properties then the

system will eliminate any location where collection of material can take place, hence the system will be self cleaning.

The other parts of the pneumatic system that are not mentioned are primarily self cleaning by definition. The venturi is the beginning of where the material enters the conveyance system, this means that through the venturi is a negative pressure. The only way the venturi will not be self cleaning is if the venturi become blocked due to an overload in material being passed through it at one time. Due to the beater and the limitations it has in removing large amount of crop material at one time the venturi will not become blocked. This is the case as the material coming from the beater is only a small amount and is a continuous flow rather than a blob of material. The cyclone like the venturi won't have a problem with self cleaning, due to the volume of the material being harvested and the size of the cyclone. All the material will fall through the cyclone under gravity, hence the material will not block the cyclone at any time. Since the blower is upstream of where the material enters the stream, there is no chance of the blower even becoming dirty, let alone needing it to self clean.

OH&S Risks

The OH& S risks associated with the pneumatic conveyor revolve around the blower. This is the case as the system is under low pressure and the exit of fluid is at a controlled point.

The risks with the blower are in reference to the impeller and the speed the impeller is spinning at. The design of the housing at this point is to allow the fan to draw air in from atmosphere. This entry point is a series of holes through the main housing of the beater. The only time the fan may become a risk is if the holes in the housing are large enough for the extremities of the body to fit through them and come in contact with the rotating fan. In figure 6.4 the entry holes for the fluid can be seen, the size of these holes can be adjusted by reducing the diameter of the drill used to cut the holes. To avoid having an inverse impact on the action of the fan, more holes would be needed to compensate for the reduction in size.

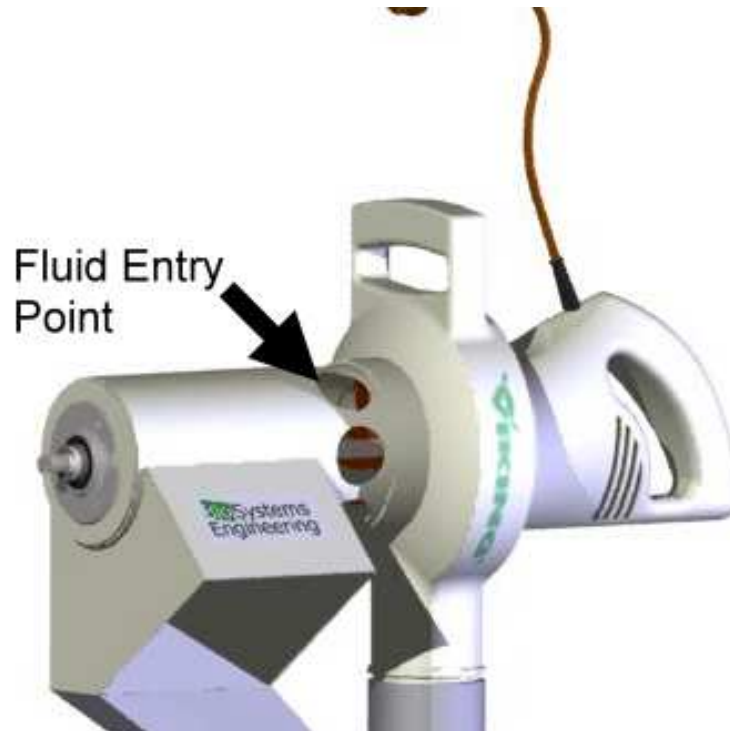

Figure 6.4: The Prototype Handpiece showing the Fluid Entry Point

The other risk is the risk of exposure to noise, and the constant noise of the fan and beater. The operator must wear ear protection to operator the blower, If the operator does not wear ear protection, they are at risk of having damage to their hearing.

Ergonomic Design

The pneumatic system doesn't really have a direct interaction with the operator, therefore, the ergonomic design is not really vital to the success of the project. The only place the operator is in contact with the pneumatic system is where the pneumatic system connect to the base of the handpiece. This is the point where the venturi introduces the material into the conveyance stream and where the conveyance system begins. The only other place where the operator interacts with the pneumatic system is at the control valve of the separation line.

To insure that the pneumatic system is ergonomic the system must not limit the ability of the operator at the handpiece. The tube must not add much weight between the

handpiece and where the tube becomes supported by the ground. Also the tube must not be too heavy to pull across the ground. Currently the tube that is used will be adequate at this stage, currently the weight is okay but as there isn't a proper joint, the tube can become twisted and apply a rotational force to the handpiece. Once the proper joints are fitter the rotational force will be dissipated.

The ergonomic design of the valve insure that the operator can't injure themselves by bumping up against a sharp corner, jamming a finger in the operation of it or having it in such a place that it is a danger to the operator to correctly use the valve. These issues are not a problem in this system, the valve is located at the base of the separation chamber. This insures that no extra weight is added to the handpiece and the location of the chamber on the trolley means that the valve is away from the operators walking path. The placement is not out of the way too much, as it is also near where the collection of the seed takes place.

6.3.4 Sorting Chamber

The evaluation of the sorting chamber is not quite as critical as the other sections. The sorting chamber has already been evaluated in previous research as stated previously. The evaluation of this part of the system is more to insure that the sorting chamber will fit together with the other components to make up the system.

The two critical points where the sorting chamber is interacting with other parts of the system is at the diffusion point and at the exit point. At the diffusion point the crop material from the plot that has just been harvested is flowing in from the bottom of the cyclone.

The vertical moving air stream will take the trash vertically away from the grain, this vertically moving air stream will then need to be introduced back into the faster moving conveyance line coming from the fluid exit point of the cyclone. The two exit streams will converge into one pipe and be carried to the final exit point.

The two problems that are likely to occur if the system is not correct are as follows:

- Due to the cyclone being an open base rather than a closed base, the fluid may disrupt the flow of material into the sorting chamber.
- Where the two exit streams meet the faster flowing stream blocks the slower moving stream from entering hence increasing the pressure upstream of the meeting point and has the possibility of changing the properties of the pneumatic systems upstream.

In regards to the first point, the feed angle is at 60° which is great enough to allow the material to slide through into the sorting chamber. Since the tests have been carried out on the diffusing system it can now be assured that the cyclone having an open base, won't effect the sorting chamber in any negative way. It has been noted in the work done by [Farran & MacMillan , 1979,] that the optimum velocity for the best separation is between 3.0ms^{-1} and 6.8ms^{-1} but has also been known to work as low as 2.6ms^{-1} . This means that if the feed rate is increased or the material is entering in one large group then the air speed needs to be increased. Since the valve controls the air speed within the chamber it will be a simple case of adjustment once the operator sees what is happening. Due to the unknowns of the crop conditions other factors may also influence the air speed needed, such as moisture content, grain quality and grain type.

To ensure that the exit ports are adequate and do not induce any further back pressure on the sorting system, the exit ports must be of a large diameter. The diameter must be of a size so that when the two streams meet, the velocity of the stream coming from the top of the cyclone is almost the same as the stream from the top of the sorting chamber. This will ensure that the streams meet and carry all the trash away from the operator.

6.4 Conclusion

Throughout this chapter the aim has been to verify that the design of the prototype system works. The verification is in terms of the design specification set out in chapter 3.

The verification of the pneumatic and diffusing systems for this prototype were more of a check to see that the numbers used to design components were actually what was happening in the system. This verification mainly dealt with the velocity of fluids as the material is moved from one system to another. Since the sorting device is taken from a previous research paper, the only testing carried out was to ensure that the fluid flow through the device was the same as in the research paper. All velocities were in the vicinity of the design velocities so the verification ensured that the prototype system would work as it was meant to.

Unfortunately, the testing of the beater type hand piece was not possible. Due to the unavailability of test barley and wheat it was not possible to carry out tests to determine whether the beating action at 10,000 revolutions per minute (rpm) would damage the barley. For the purpose of optimizing this prototype the testing is not critical at this point. The major optimizing needs to take place in the weight of the handpiece. In reducing the weight the drive mechanism will be changed and the need for the fan to be a part of the handpiece will also be reviewed. If changes are made and a motor purely for the drive is used rather than a motor for both the fan and the drive, then the appropriate motor can be used to obtain a rotational speed of the beater back in the magnitude of 3,000 (rpm).

Chapter 7

Recommendations for Prototype Improvements

7.1 Prototype Improvements

The improvements section is where all the changes necessary to take this prototype system from just a prototype to a system that is manufacturable and what the client wants to purchase. The following section are the details of the changes.

7.1.1 Pneumatic System Improvements

The pneumatic system works in principal and is quite effective in carrying out the objectives of the system. Currently the only fault with the pneumatic system is dealing with fan and the location of the fan. Currently the fan is located within the handpiece; this adds weight to the handpiece and means that all the air lines need to come from the handpiece to where they are needed, hence there are two tubes plus an electric cord attached to the handpiece.

The proposal is to have a fan unit located with the cyclone and sorting chamber hence eliminating the need for a fan inside the handpiece. This fan unit will have similar

properties to the current fan and will connect to the pneumatic system in a similar way. In doing this, several advantages are made. Firstly, a large venturi can be taken of the discharge side of the fan and this will make the suction tube that will need to be between the conveyance line and the handpiece, hence reducing the tubes coming from the handpiece. The other advantage is in the splitting of the air stream to allow the secondary line for separation; this splitting device can be made much simpler. Since weight is now not an issue, the splitting device can be made using a similar system as to what they do currently in agricultural machinery.

The new pneumatic system will be:

1. Centrifugal fan.
2. Splitting device just downstream of the fan and a tube connecting the split to the sorting chamber. The split will need to be such that the volume split for the sorting chamber is above the maximum requirement to operate the chamber as discussed in section 5.3.
3. Large venturi capable of large suction through a long tube connected to the handpiece.
4. Conveyance tube to the inlet of the cyclone.
5. Valve on the tube between the splitting device and the sorting chamber.
6. An exit system such that the exit from the cyclone and the sorting chamber merge into one tube and exit a safe distance away from the operator.

See figure 7.1 for a virtual model showing the recommended pneumatic set up.

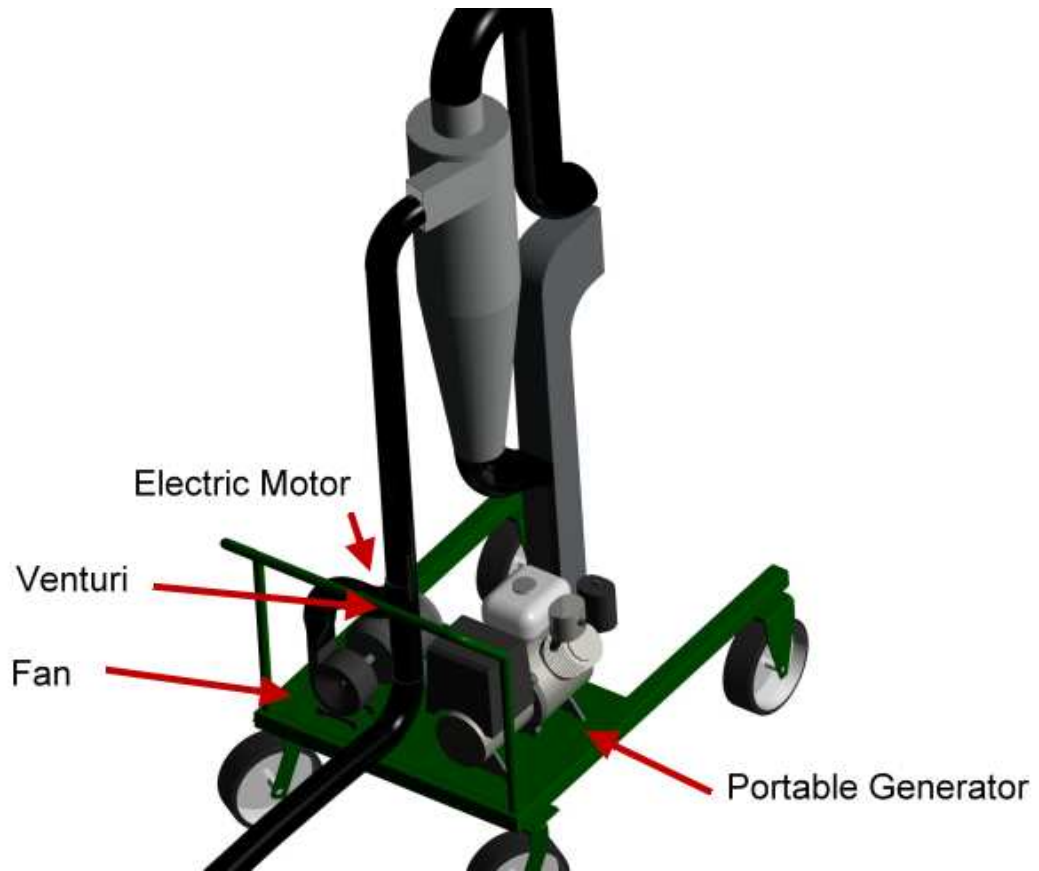

Figure 7.1: Figure showing the recommended pneumatic set up

7.1.2 Handpiece Improvements

Now that the handpiece is without the fan, there is no need to use a design that connects to the front of a garden blower. The main improvement with the handpiece are regarding the modification in design without the fan.

The modification will mean that the handpiece will become much lighter and far more portable and user friendly. The beater design will not change, the change will be the drive mechanism and the handle mechanism.

The new drive mechanism will be an electric motor directly coupled onto the shaft of the beater. Without the fan, there is now no need for the fluid entry holes and, therefore, this area will be replaced with the motor. Since the tube attaching to the handpiece will be purely vacuum, the tube can attach directly to the handpiece in a

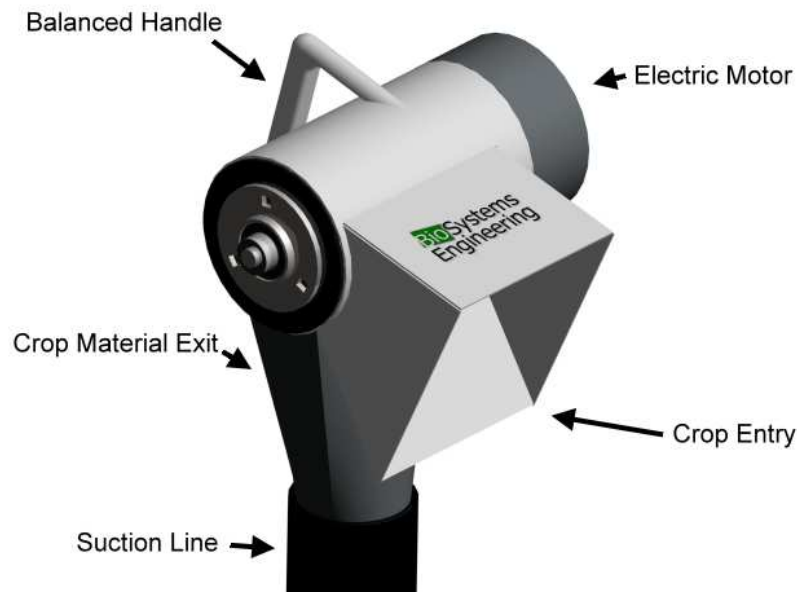

Figure 7.2: Figure showing the recommended handpiece

more streamline manner than is currently being used. This will aid in weight reduction and handpiece stability. The shell of the handpiece will also be made from plastic, further reducing the weight of the handpiece. The final modification is the addition of a handle that will align within the same axis as the centroid of the handpiece. This will be an advantage as the handpiece will then be balanced and light. Figure 7.2 shows a view of the recommended hand piece.

7.1.3 Sorting Chamber Improvements

The sorting chamber is already a working system and with the design from the previous research there was not much to do to test this device. The only improvement that can be implemented is the size. Currently there is a large chamber in which the separation takes place which has the possibility to be optimized. From viewing the chamber while it is operational, it can be seen that the separation takes place in a small distance either side of the entry point of the material. Since the sorting takes place in this section, it may be possible to reduce the size of the chamber and save room in the system. There has been little research conducted on the dimensions of the chamber and further testing needs to be carried out to see how compact this device can be made.

7.1.4 Overall Improvements

The system as a whole works well together, although it does not fit together as a system. In this the individual parts that make this system are still individual parts, the real value of this system will only be seen when all the parts of the system are fixed together on one moveable trolley. The final improvement is to fit the sorting chamber, the cyclone, the fan unit, the pneumatic control and the power source.

These components have the ability to sit together on one simple trolley and be a compact and portable device. If the power source is a generator, the generator and the fan can sit on the floor of the trolley with the cyclone and sorting chamber somewhat suspended above the trolley. This will enable the easy collection of the samples and the maintenance of such a simple device will be able to be carried out by the operator.

In figure 7.3 and 7.4 are views of the full system. The views are from the rear isometric so that the exit points can be seen and the normal isometric so that all the components of the system can be seen.

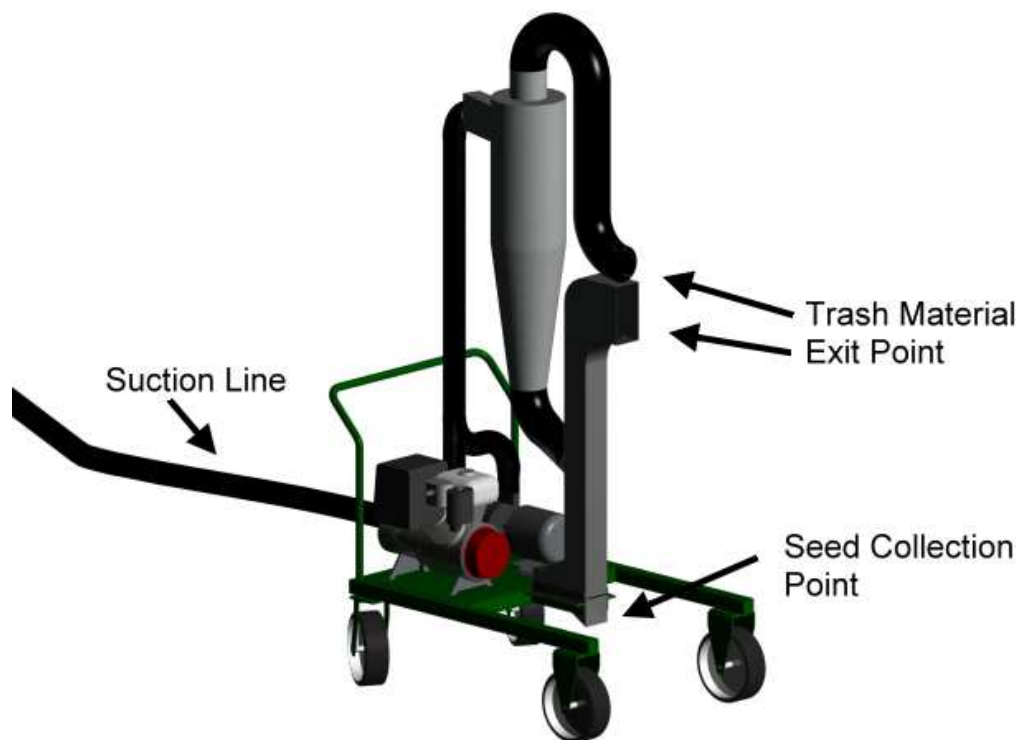

Figure 7.3: The rear view of the trolley set up



Figure 7.4: Picture showing the full recommended system

Chapter 8

Conclusions

The design of the prototype hand held harvesting system is the object of this project. In designing and building such a system, it was aimed to increase the efficiency of research of black point in wheat and barley. The current process of harvesting the trials for black point research is to use manual labor to collect the heads from the stalks of wheat and barley in the field. The heads are then bagged and transported to a stationary thrasher. The thrasher then thrashes the heads that were collected and finally the sample is cleaned and ready for analysis. In short the project designed a system where all the current processes are completed in one simple and easy to use device.

The device as the current prototype can be seen in figure 6.1. Currently the prototype uses a Viking garden blower as the pneumatic power source and the drive mechanism for the beater handpiece. The heads of wheat come in contact with the beater and the grain is stripped from the stalk only taking the husks with the grain. The grain and plant material is transported to a diffuser where the material is removed from the airstream to fall under gravity. Gravity then feeds the material into a stream of vertical air, the grain falls through the stream while the plant material is lifted up and away from the grain sample. The grain sample is collected at the base of the sorting chamber where the air stream is present. The sample is then collected via a slide gate. Once the grain is removed, the system is completely clean. At no point in the system is there any place for the crop material to collect and contaminate the following sample.

The system described above and in previous chapters is not a full working system. The prototype proves that the concepts work and that the concepts can be fitted together in a system and achieve most of the design objectives. The only design objective that is not met is the ergonomics of the handpiece. The design objective was that the system would allow the operator extended periods of use without expelling more energy than is really required. Currently the system is far too heavy and simply not portable.

The recommendations in chapter 7 take this prototype system and outline ways in which the system can be improved to achieve this final objective. Currently the final system has not been built and the manufacture of such a system is waiting for further instruction from the client to allow the final changes to the prototype to be completed before the manufacturing commences.

References

- [Griffin, 1973,] George A. Griffin, *Fundamentals of Machine Operations, Combine Harvesting*, John Deere, 1973,
- [Farran & MacMillan , 1979,] I. G. Farran and R. H. MacMillan , *Grain- Chaff Separation in a Vertical Air Stream*, The British Society for Research in Agricultural Engineering, 1979.
- [Mohsenin, 1986,] Nuri. N. Mohsenin, *Physical Properties of Plant and Animal Material; structure, physical characteristics, and mechanical properties*, Gordon and Breach, New York, 1986.
- [Chadwick, Morfett & Borthwick, 2004,] Chadwick A., Morfett J, Borthwick M., *Hydraulics in Civil and Environmental Engineering*, Fourth Edition, Spon Press, New York, 2004.
- [Davis & Cornwell, 1998,] Davis M., Cornwell D., *Environmental Engineering*, Third Edition, McGraw-Hill, 1998.
- [John Deere Australia Web Site, 2005,] John Deere Australia Web Site,
url (http://www.deere.com/en_AU/equipment/ag/60series-combines/sts/fullpage.html),
2005.
- [Case New Holland Australia Web Site, 2005] Case New Holland Australia Web Site,
url (http://www.newholland.com/h4/products/products_series_specs.asp), 2005.
- [Australian Bureau of Statistics, 2004] *PRINCIPAL AGRICULTURAL COMMODITIES 2003/2004. url*,
(<http://www.ausstats.abs.gov.au/Ausstats/subscriber.nsf>), Tues 30 Nov 2004.

- [Williamson & Michalowitz, 2003] Peter Williamson & Miriam Michalowitz, *DPI Web Site url (www.dpi.qld.gov.au)*, January 2003.
- [Tado, Wacker, Kutzbach & Suministrado, 1998,] C. J. M. Tado, P. Wacker, H. D. Kutzbach & D. C. Suministrado, *Development of Stripper Harvesters: A Review*, Journal of Agricultural Engineering Research. (1998) 71, 103112 Article No. ag980318
- [Houston D.F., 1972] Houston D.F.(ed.), *Rice Chemistry and Technology*, American Association of Cereal Chemists, St Paul U.S.A., 1972.
- [Klinzing, Marcus, Rizk F. & Leung, 1997,] Klinzing G. E., Marcus R. D., Rizk F. & Leung L. S., *Pneumatic Conveying of Solids, A Theoretical and Practical Approach*, Second Edition, Chapman & Hall, London, 1997.
- [Calvin & Davis 2000] Calvin F., Davis M. A., *Single Row or Plant Combine Harvesting Machine*, Patent Patent Number WO 00/08915, Northwest Plant Breeding Co., Pullman U.S.A. 2000.
- [1] Hancock, N., *ENG4111/4112 Research Project – Project Reference Book – A and B*, University of Southern Queensland, Toowoomba, Queensland, Australia, pp. 105-125.
- [2] N. H. Grove-Jones, *Grain Harvesting in Australia and New Zealand*, Stock Journal Publishers, Adelaide, 1972,
- [3] G. Quick and W. Buchele, *The Grain Harvesters*, American Society of Agricultural Engineers, Michigan, 1978,
- [4] F. P. Beer and E. R. Johnston, *Vector Mechanics for Engineering, Statics and Dynamics*, Mc Graw-Hill Inc. 1988, pp 495.

Appendix A

Appendix A

University of Southern Queensland
FACULTY OF ENGINEERING AND SURVEYING

ENG 4111 / 4112 Research Project

PROJECT SPECIFICATION

FOR: **Justin Carl SCHULTZ**

TOPIC: Development of a hand held harvesting system
for use with wheat and barley.

SUPERVISORS: Dr Guangnan Chen
Richard Sulman, Biosystems Engineering

ENROLMENT: ENG 4111 – S1, D, 2005
ENG 4112 – S2, D, 2005

PROJECT AIM: This project aims to research current harvesting
systems and patents, analyze past methods of harvesting,
and develop the most effective and easiest method for
harvesting small trial plots of wheat and barley.

SPONSORSHIP: Biosystem Engineering

PROGRAMME: **Issue B, 27 October 2005**

OBJECTIVES:

1. Research possible methods for the grain removal, threshing, and cleaning.
2. Analyze larger working models in the industry.
3. Determine feasibility to reduce the size of the large working systems to a more manageable and cost effective product.
4. Design a number of possible prototypes using a solid modelling program.
5. Analyze and determine the most effective prototype.
6. Build the prototype.

7. Test the prototype to determine the effectiveness of the design and possible improvement to any part of the harvesting mechanism.

AGREED:

----- (Student) -----, ----- (Supervisors)

---/---/--- ---/---/--- ---/---/---

Appendix B

Prototype Design Drawings

DRAWING REVISIONS

REV.	DESCRIPTION	DATE	APPROVED

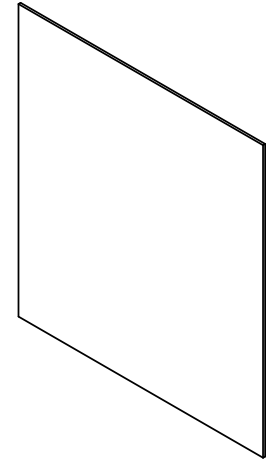
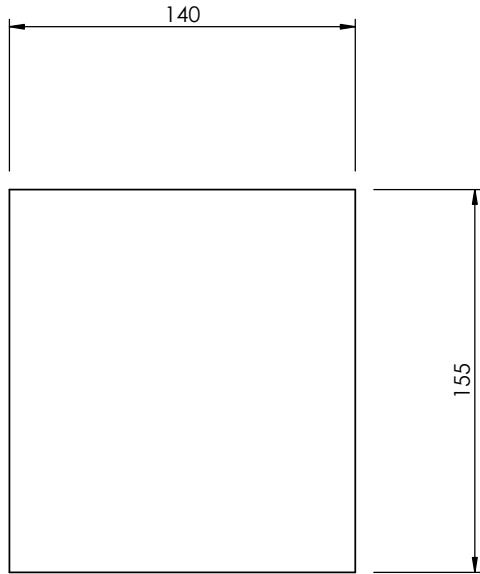

TOLERANCE U.N.O.		DRAWN		BIOSYSTEMS © 9 Cristina Crt ENGINEERING Highfields QLD 4352 07 4698 7828	
LINEAR ±0.1mm ANGULAR ±0.2°		R SULMAN			
		DATE			
		APPROVED		TITLE	
				CROP GUIDE	
				PART No.	
		DRAWN TO AS1100 DO NOT SCALE		HH040	
				REV.	
				A4	

PART No.	DESCRIPTION	SIZE	GRADE	MASS
HH040				

DRAWING REVISIONS

REV.	DESCRIPTION	DATE	APPROVED

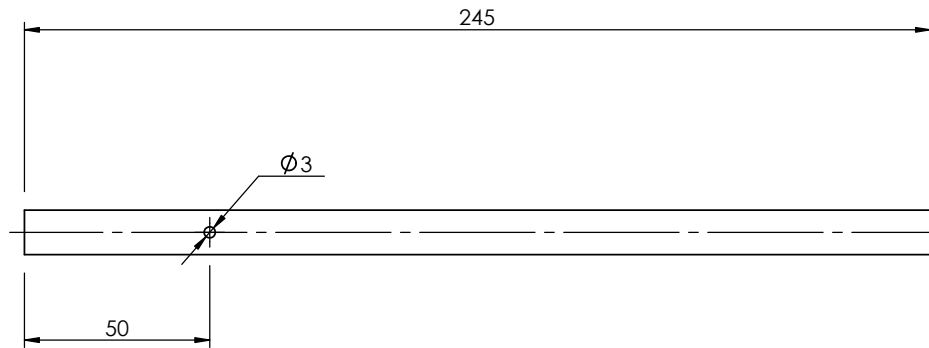
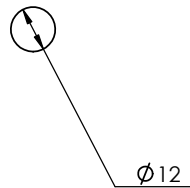
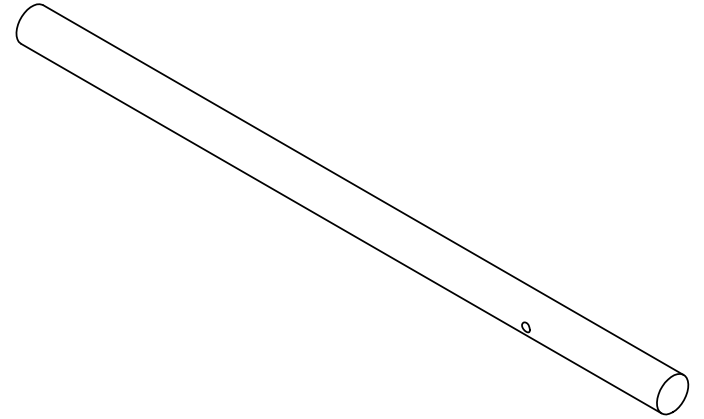

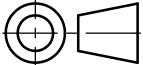
TOLERANCE U.N.O. LINEAR $\pm 0.1\text{mm}$ ANGULAR $\pm 0.2^\circ$	DRAWN R SULMAN	BIOSYSTEMS © ENGINEERING	9 Cristina Cr Highfields QLD 4352	
	DATE		07 4698 7828	
	APPROVED	TITLE SHAFT	SHEET 1 OF 1	
	DRAWN TO AS1100 DO NOT SCALE		PART No. HH036	REV.

HH036				
PART No.	DESCRIPTION	SIZE	GRADE	MASS

DRAWING REVISIONS

REV.	DESCRIPTION	DATE	APPROVED

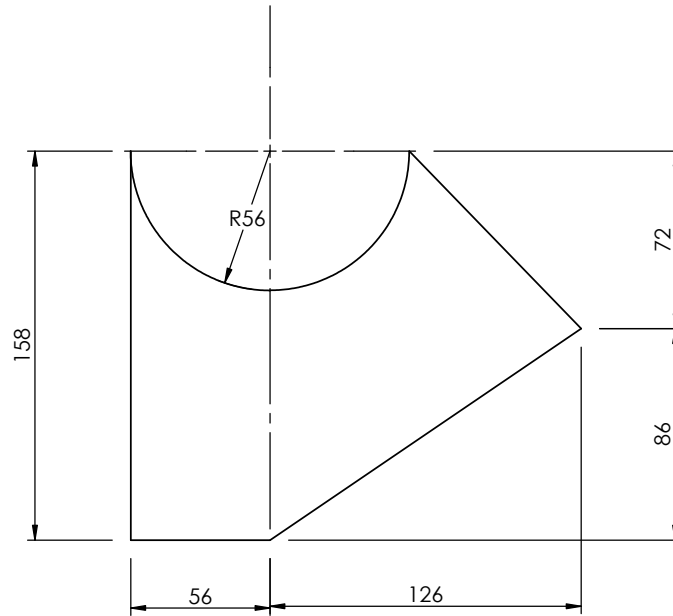
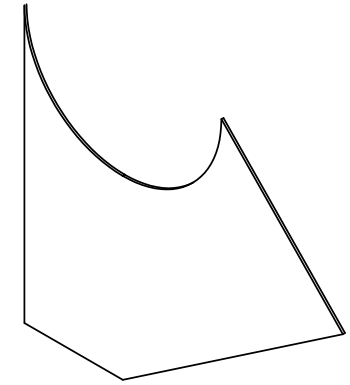

TOLERANCE U.N.O. LINEAR ±0.1mm ANGULAR ±0.2°	DRAWN R SULMAN	BIOSYSTEMS ENGINEERING © 9 Cristina Crt Highfields QLD 4352 07 4698 7828	SHEET 1 OF 1		
	DATE		TITLE CROP GUIDE		
	APPROVED	PART No.	HH035	REV.	A4
	DRAWN TO AS1100 DO NOT SCALE				

HH035				
PART No.	DESCRIPTION	SIZE	GRADE	MASS

DRAWING REVISIONS

REV.	DESCRIPTION	DATE	APPROVED

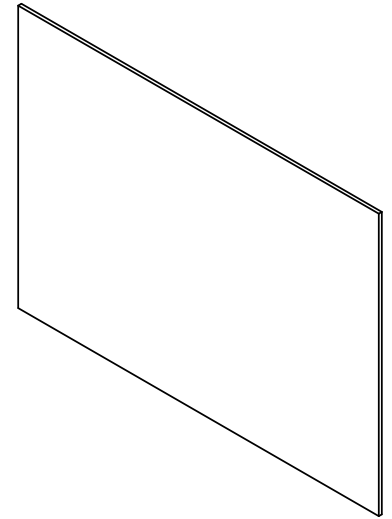
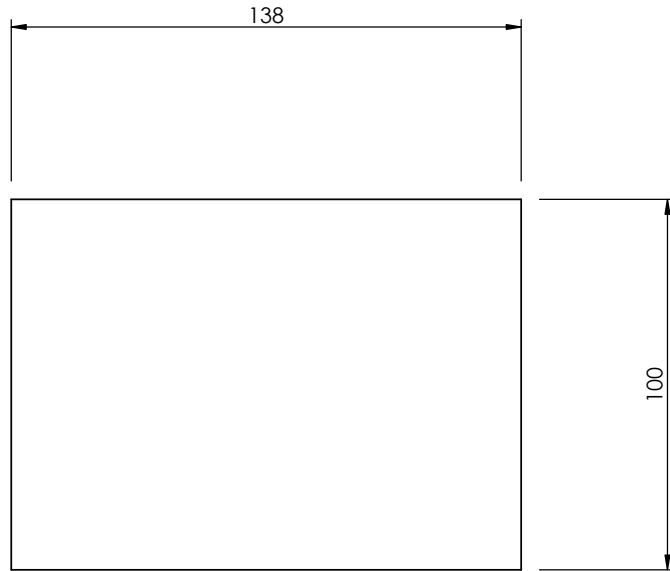

TOLERANCE U.N.O.		DRAWN		BIOSYSTEMS © 9 Cristina Crt ENGINEERING Highfields QLD 4352 07 4698 7828	
LINEAR ±0.1mm ANGULAR ±0.2°		R SULMAN			
		DATE			
		APPROVED		TITLE	
				CROP GUIDE	
				SHEET 1 OF 1	
PART No.		DRAWN TO AS1100 DO NOT SCALE		REV.	
HH034				A4	
DESCRIPTION		SIZE		GRADE	
				MASS	
				PART No. HH034	

HH034				
PART No.	DESCRIPTION	SIZE	GRADE	MASS

DRAWING REVISIONS			
REV.	DESCRIPTION	DATE	APPROVED

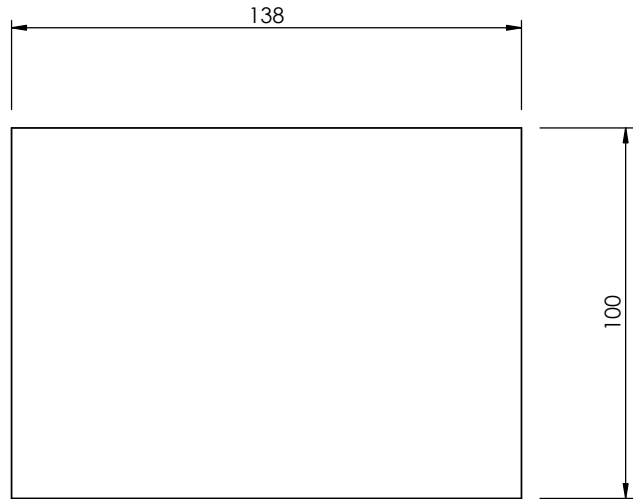
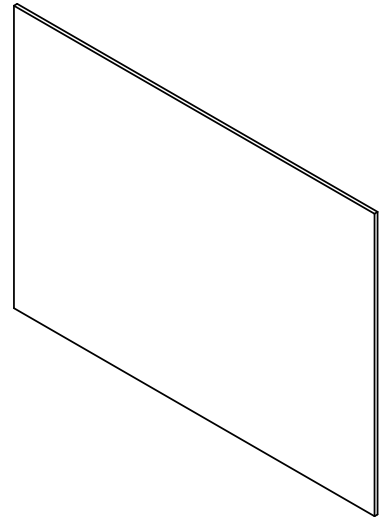

TOLERANCE U.N.O. LINEAR ±0.1mm ANGULAR ±0.2°	DRAWN R SULMAN	BIOSYSTEMS ENGINEERING © 9 Cristina Crt Highfields QLD 4352 07 4698 7828	SHEET 1 OF 1	
	DATE		TITLE CROP GUIDE	
	APPROVED	PART No.	HH033	REV.
	DRAWN TO AS1100 DO NOT SCALE		A4	

HH033				
PART No.	DESCRIPTION	SIZE	GRADE	MASS

DRAWING REVISIONS

REV.	DESCRIPTION	DATE	APPROVED

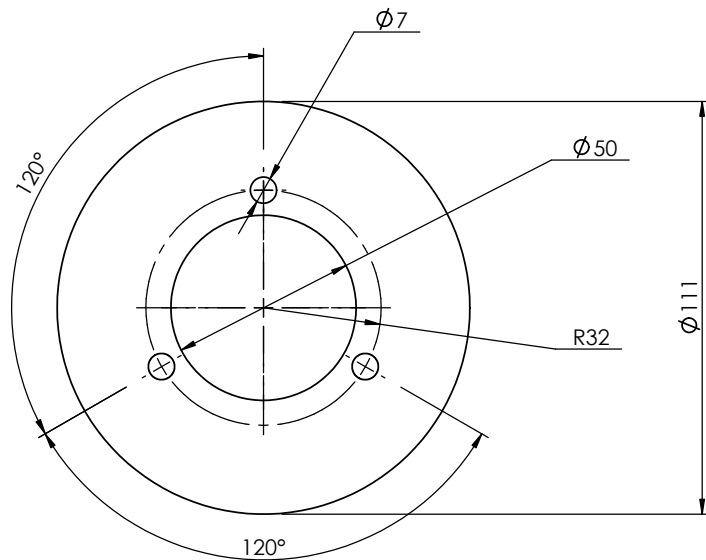
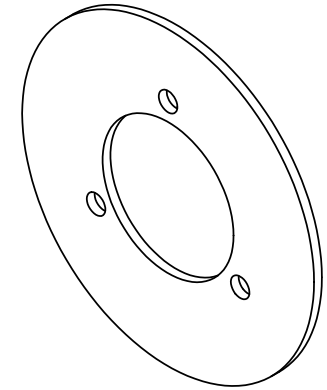

TOLERANCE U.N.O. LINEAR ±0.1mm ANGULAR ±0.2°	DRAWN R SULMAN	BIOSYSTEMS ENGINEERING © 9 Cristina Cr Highfields QLD 4352 07 4698 7828	SHEET 1 OF 1
	DATE		
	APPROVED	TITLE END CAP	REV.
	DRAWN TO AS1100 DO NOT SCALE		

PART No.	DESCRIPTION	SIZE	GRADE	MASS
HH032	3MM	3MM	250	

A4

DRAWING REVISIONS

REV.	DESCRIPTION	DATE	APPROVED

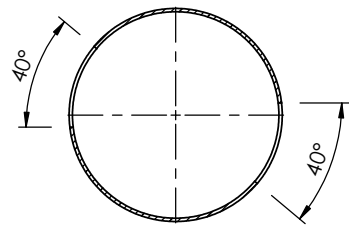
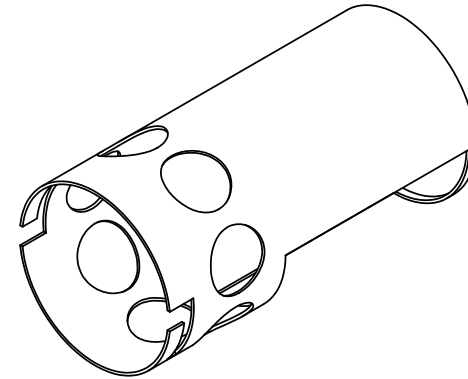

SECTION D-D
SCALE 1 : 4

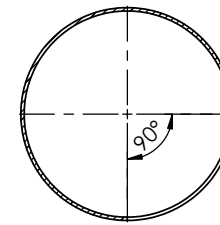
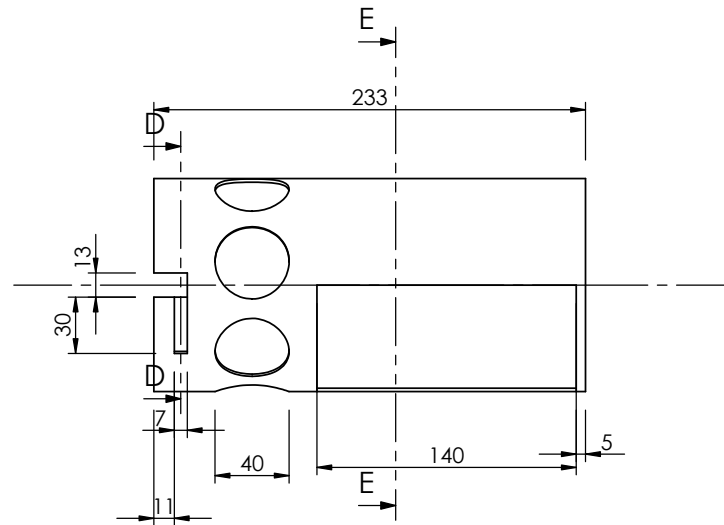

SECTION E-E
SCALE 1 : 4

TOLERANCE U.N.O. LINEAR ±0.1mm ANGULAR ±0.2°	DRAWN R SULMAN	BIOSYSTEMS © ENGINEERING	9 Cristina Cr Highfields QLD 4352 07 4698 7828	
	DATE		APPROVED	TITLE BARREL
DRAWN TO AS1100 DO NOT SCALE		PART No. HH029	REV.	A4

PART No.	DESCRIPTION	SIZE	GRADE	MASS
HH029				

DRAWING REVISIONS

REV.	DESCRIPTION	DATE	APPROVED

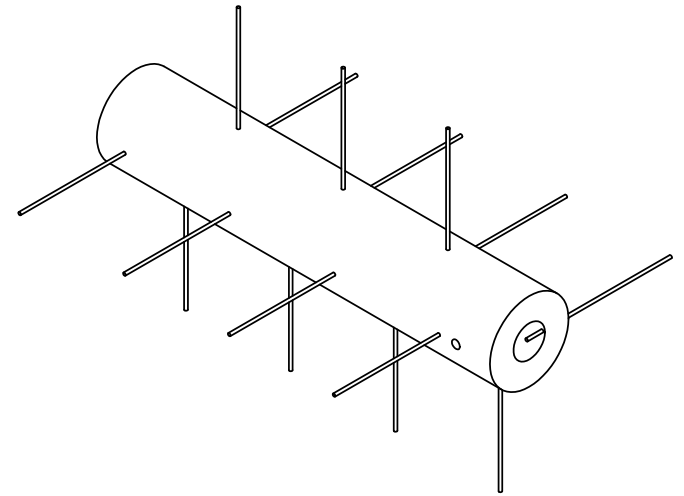
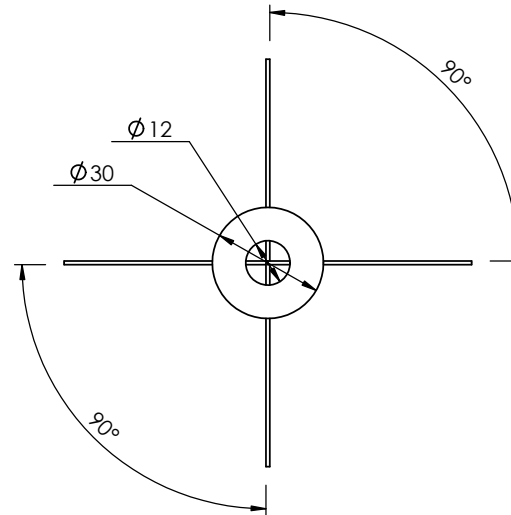
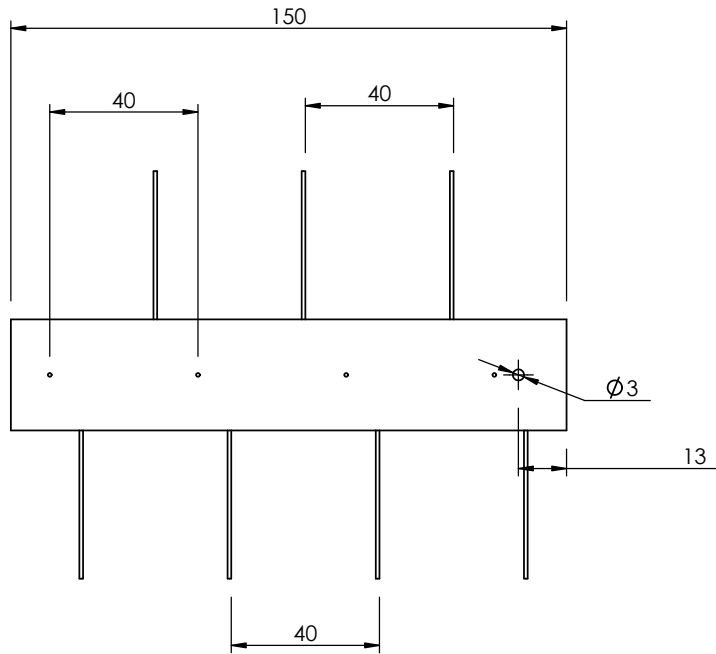

TOLERANCE U.N.O.		DRAWN R SULMAN		BIOSYSTEMS © 9 Cristina Crt ENGINEERING Highfields QLD 4352 07 4698 7828		
LINEAR ±0.1mm ANGULAR ±0.2°		DATE				
		APPROVED		TITLE BEATER		
		DRAWN TO AS1100 DO NOT SCALE		PART No. HH028		
HH028				SHEET 1 OF 1		
PART No.	DESCRIPTION	SIZE	GRADE	MASS	REV.	A4

HH028				
PART No.	DESCRIPTION	SIZE	GRADE	MASS

DRAWING REVISIONS

REV.	DESCRIPTION	DATE	APPROVED

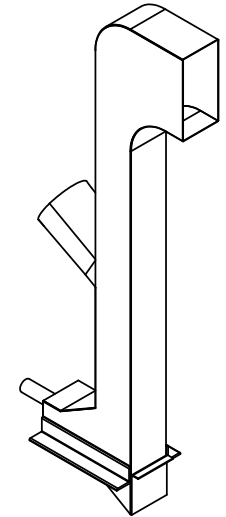
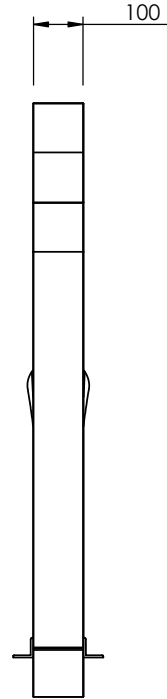
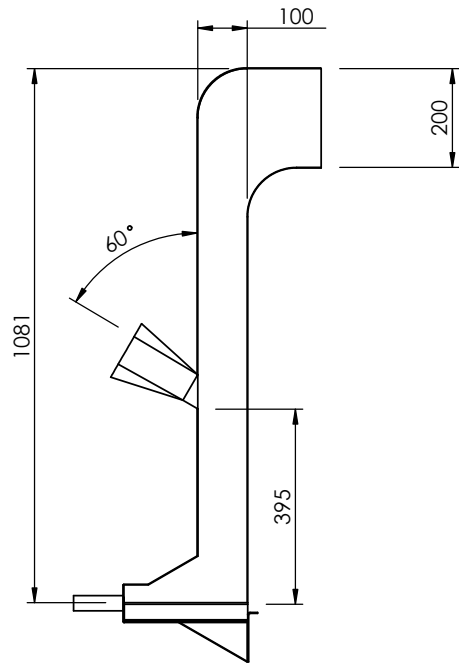

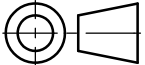
TOLERANCE U.N.O. LINEAR ±0.5mm ANGULAR ±0.5°	DRAWN R SULMAN	BIOSYSTEMS © ENGINEERING	9 Cristina Crt Highfields QLD 4352 07 4698 7828		
	DATE		TITLE SORTING CHAMBER	SHEET 1 OF 1	
	APPROVED	PART No.	HH012AS	REV.	A4
	DRAWN TO AS1100 DO NOT SCALE				

DRAWING REVISIONS

REV.	DESCRIPTION	DATE	APPROVED

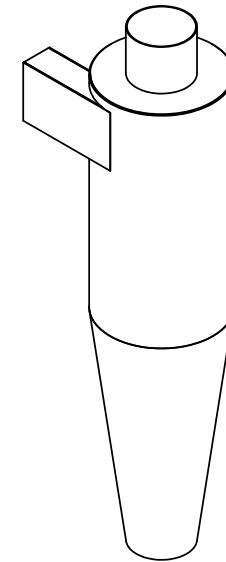
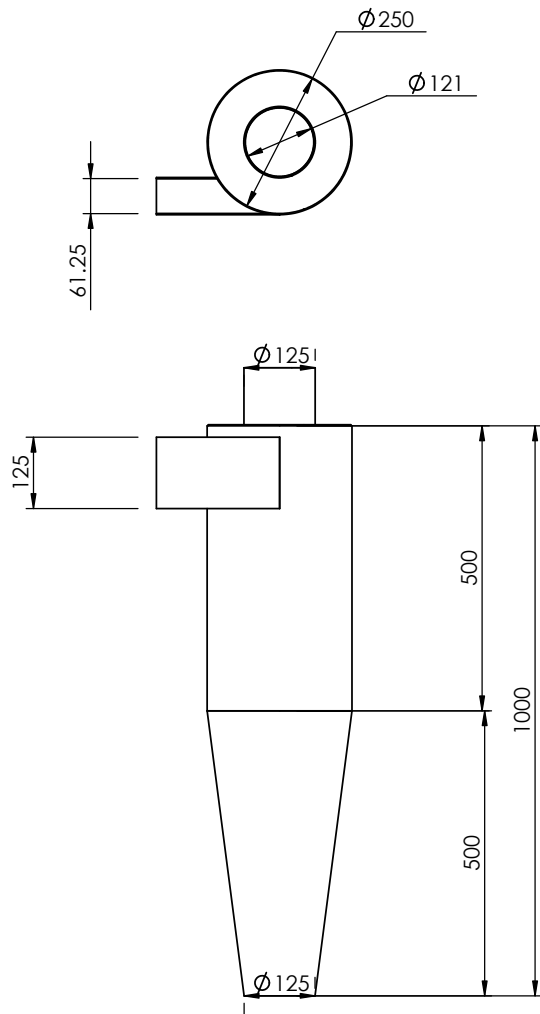

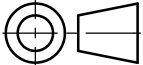
TOLERANCE U.N.O. LINEAR $\pm 0.5\text{mm}$ ANGULAR $\pm 0.5^\circ$	DRAWN R SULMAN	BIOSYSTEMS © ENGINEERING	9 Cristina Crt Highfields QLD 4352 07 4698 7828		
	DATE		TITLE 250mm Cyclone	SHEET 1 OF 1	
	APPROVED	PART No.	HH011AS	REV.	A4
	DRAWN TO AS1100 DO NOT SCALE				

DRAWING REVISIONS

REV.	DESCRIPTION	DATE	APPROVED

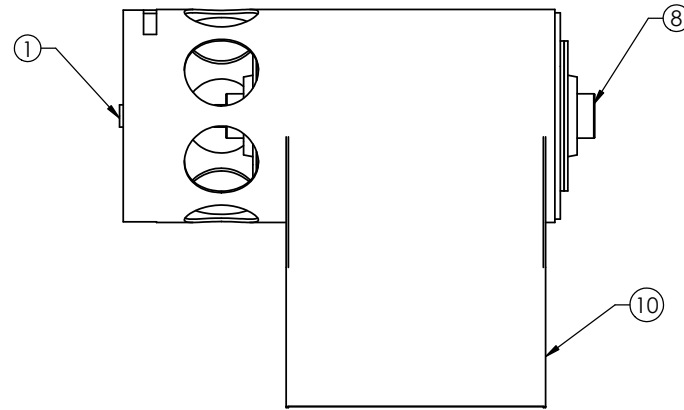
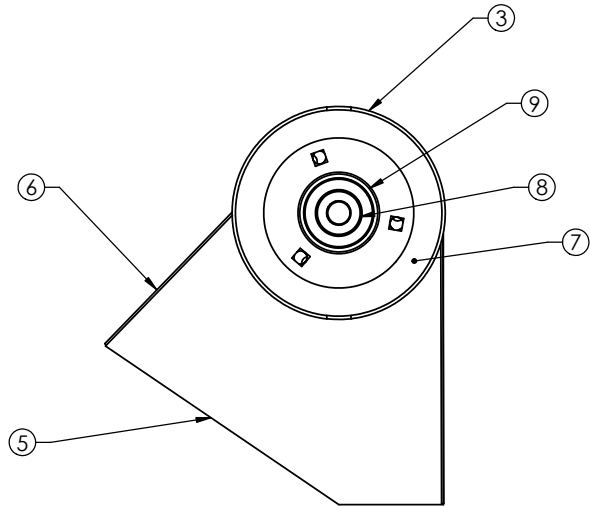
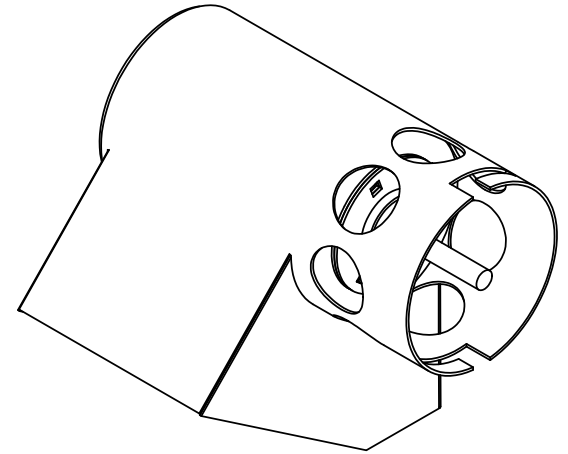

ITEM NO.	PART NUMBER	DESCRIPTION	QTY.
1	HH036	SHAFT	1
2	HH028	BEATER BOSS	1
3	HH029	BARREL SHELL	1
4	HH033	CROP GUIDES	1
5	HH035	CROP GUIDES	2
6	HH034	CROP GUIDES	1
7	HH032	END PLATE	2
8	EN201	BEARINGS	2
9	40MS	BEARING Housing	4
10	HH040	CROP GUIDES	1

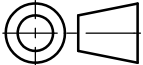
TOLERANCE U.N.O.		DRAWN		BIOSYSTEMS © ENGINEERING		9 Cristina Crt Highfields QLD 4352 07 4698 7828	
LINEAR ±0.5mm ANGULAR ±0.5°		R SULMAN					
		DATE		TITLE HANDPIECE PROTOTYPE		SHEET 1 OF 1	
		APPROVED					
				PART No. HH006AS		REV.	A4